

Kollmorgen Frameless Motor Selection Guide

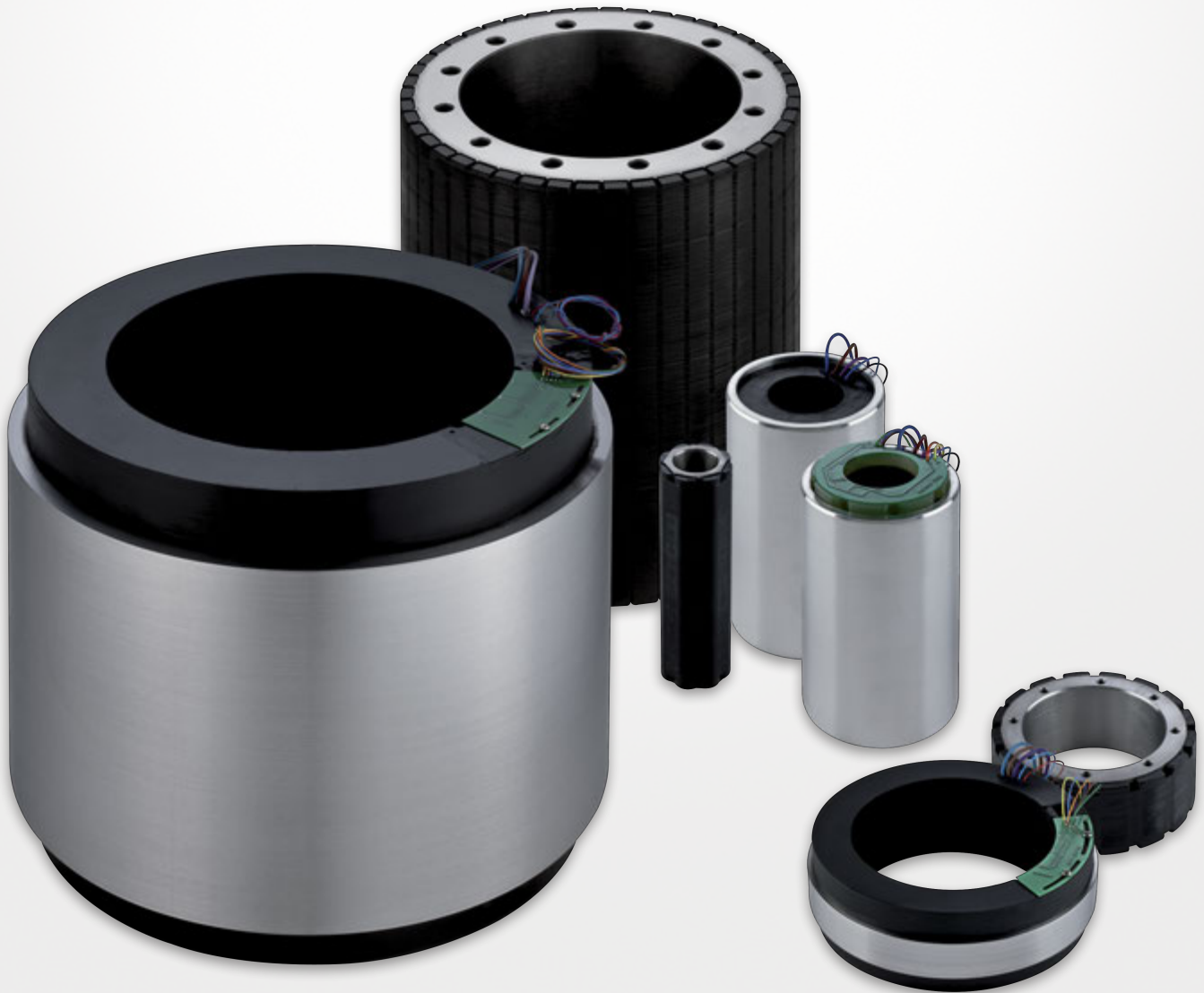

KBM™ Series Brushless Motors

KOLLMORGEN®

Because Motion Matters™

Kollmorgen: Your partner. In Motion.

Every solution comes from a real understanding of the challenges facing machine designers and users.

Innovators consistently rate Kollmorgen as one of their best motion systems manufacturing partners. Whether you are looking for classic servo motors, direct-drive servo motors, stepper motors, drives & amplifiers, gearing, actuation, or CNC & multi-axis motion controllers, Kollmorgen is one of the few companies in the world whom actually design and manufacture all of these products.

Our customers are leaders in many industries such as Aerospace & Defense, Printing, Packaging & Converting, Food & Beverage Processing, Medical Imaging, Invitro Diagnostics & Laboratory Automation, Pharmaceutical Manufacturing, Material Forming and Cutting, Oil & Gas, and Robotics. Kollmorgen is also a leader in Warehouse Automation, including complete AGV systems, software, awareness and autonomy.

Our Automation Solutions can be found on Mars and in space, Ships and submarines, O&G drilling and metrology, Surgical robots and laser eye surgery, even inside of artificial hearts. These are just a few applications that demand high performance and high quality while satisfying their specific needs.

Because motion matters, it's our focus: Motion can distinctly differentiate a machine and deliver a marketplace advantage by increasing its performance and dramatically improving OEE.

High-performance motion can make your customer's machine more reliable and energy-efficient, enhance accuracy and improve operator safety. Motion also represents endless possibilities for innovation.

We've always understood this potential, and thus have kept motion at our core and in our Vision, Mission & Values, relentlessly developing products that offer precise control of torque, velocity and position accuracy in machines that rely on complex motion.

Removing the Barriers of Design, Sourcing, and Time

At Kollmorgen, we know that OEM engineers can achieve a lot more when obstacles aren't in the way. So, we clear obstacles in three important ways:

Integrating Standard and Custom Products

The optimal solution is often not clear-cut. Our application expertise allows us to modify standard products or develop totally custom solutions across our whole product portfolio so that designs can take flight.

Providing Motion Solutions, Not Just Components

As companies reduce their supplier base and have less engineering manpower, they need a total system supplier with a wide range of integrated solutions. Kollmorgen offers complete solutions as well as motion subsystems that combine programming software, engineering services and best-in-class motion components.

Global Footprint

With direct sales, engineering support, manufacturing facilities, and distributors spanning the Americas, Europe, Middle East, and Asia, we're close to OEMs worldwide. Our proximity helps speed delivery and lend support where and when they're needed.

Financial and Operational Stability

Kollmorgen is part of Danaher Corporation. A key driver in the growth of all Danaher divisions is the Danaher Business System, which relies on the principle of "kaizen" – or continuous improvement. Using world-class tools, cross-disciplinary teams of exceptional people evaluate processes and develop plans that result in superior performance.

Kollmorgen: Your partner. In Motion.

Table of Contents

▶ KBM™ Series Frameless Brushless Motor	4
▶ KBM(S)™ Continuous Torque Overview	7
▶ KBM(S)™ Motor Data and Dimensions	
KBM 10	8
KBM 14	14
KBM 17	18
KBM 25	24
KBM 35	30
KBM 43	36
KBM 45	42
KBM 57	46
KBM 60	52
KBM 79	58
KBM 88	64
KBM 118	70
KBM 163	76
KBM 260	80
▶ Mounting and Installation Guidelines	
Safety	84
Packaging, Transport, Storage, Operation	86
User Interface Responsibilities	89
Stator Mounting	90
Rotor Mounting to Shaft	94
Installing Rotor Inside Stator	96
Performance Enhancements	99
Electrical Wiring Interface	99
▶ Application Profile Questions	101
▶ Model Nomenclature	102
▶ Available KBM(S) Modifications	103

KBM™ Series Frameless Brushless Motor

The KBM frameless motor series is our newest direct drive technology.

KBM frameless brushless motor models are engineered to provide the high-performance, long life and simple installation that today's design engineers demand. Optional latching digital Hall effect sensors are pre-aligned and factory installed with added axial rotor length to achieve proper triggering. Choice of insulation allows operation over a wide range of line input voltage. Our detailed selection guide provides a variety of pre-engineered options and configurations that are currently available.

For customized features, contact Kollmorgen to help us understand exactly what you need and how we can further optimize any KBM or engineer a new custom motor solution for the unique requirements of your application. We are experts in providing optimized solutions such as special winding configurations, tailored mounting features, diameter and stack length dimensional adjustments, or material variations.

The Benefits of KBM Frameless Motors

- Industry-Leading Frameless Motor Performance
 - Advanced electromagnetic designs deliver maximum torque density which minimizes required motor space envelope
 - Extremely smooth rotation with minimal cogging and low total harmonic distortion (THD)
 - Broad operating speed range and rapid acceleration
- Quality Construction Ensures Reliability and Safe Operation
 - Redundant magnet attachment to rotor on high-speed models – adhesive bonding and high-strength banding
 - 155°C motor winding temperature rating with integral thermistor allows continuous safe operation for demanding applications
 - Designed with UL-recommended insulation systems to simplify system regulatory approval
 - RoHS compliant material selection
 - Compliant with Harmonized Type C Standards EN60034-1:2004 - Rotating Electrical Machines and where appropriate in accordance to the Low Voltage Directive 2006-95-EC
- Highly Configurable Design Minimizes Time to Solution
 - 14 frame sizes with multiple stack lengths
 - Standard sensor feedback using Hall effect sensors
 - Standard high and low voltage insulation
 - Multiple standard windings with custom windings available upon request
 - Mechanical interface changes easily accommodated

KBM Series Overview

Kollmorgen, the global leader in direct drive motor technology, is pleased to offer KBM series frameless brushless motors. With a wide variety of sizes and torque ranges available, KBM models are engineered to provide the high-performance, long life and simple installation that today's design engineers demand.

Quality Construction

- Fully encapsulated stator windings
- 155°C internal winding temperature continuous capability
- PTC thermistor (avalanche-type) overload protection
- High performance magnets
- Fail-safe bands over rotor magnets*
- RoHS compliant

Available Options (No engineering fees apply)

Sensor Feedback (KBMS models)

Latching digital hall effect sensors are pre-aligned and factory installed on the lead end of the stator. Wiring instructions and electrical timing diagrams are included in this selection guide. KBMS models include added axial rotor length to achieve proper sensor triggering.

Choice of Insulation System

S (standard) – acceptable for applications up to 240 Vac drive amplifier supply.

H (high voltage) – required for applications >240 Vac and up to 480 Vac drive amplifier supply.

Allowed Modifications

 (Engineering fees apply.

Consult Kollmorgen Customer Support for guidance or to obtain a quotation. Unit price increase may apply, depending upon extent of modification.)

Special Windings

Motor windings may be optimized to provide desired speed and torque performance according to the unique voltage and current requirements of a customer's application. Kollmorgen engineers must confirm electrical feasibility and manufacturability of each special winding arrangement prior to quotation.

Special Rotor Hub Dimensions

Rotor hubs may be provided with special customer-designated hole patterns, mounting features or smaller inner bore diameters. Standard KBM(S) models shown within this selection guide include the largest available inner rotor bore diameter.

Rotor Hub Material

Standard configuration KBM(S) rotor hubs are constructed from non-plated cold rolled steel. If special plating, coating, cleaning or alternate material is desired, Kollmorgen engineers must confirm feasibility and pricing adjustment prior to quotation.

Stator Sleeve Material

Standard configuration KBM(S)-10, 14, 17, 25, 35, 45, 163 and 260 size stators are designed with uncoated aluminum sleeves around the stator lamination stack. If special coating or plating is desired for the aluminum stator sleeve, Kollmorgen engineers must confirm feasibility and pricing adjustment prior to quotation. Stator sleeves are only utilized for the sizes listed above.

Agency UL Information

KBM(S) motors are designed to facilitate UL certification in the customer's higher-level assembly. Stator insulation systems are constructed entirely from agency-approved materials and are designed in full compliance with agency creepage and clearance dimensional guidelines. Dielectric strength between winding circuit and grounded metal stator surface is tested at agency-specified voltage level. Because a frameless motor's compliance with agency requirements is dependent upon correct installation and proper design of the surrounding enclosure by the user, KBM(S) series products are not formally labeled or agency-approved at the frameless motor level.

* Does not apply to KBM 163 and KBM 260.

KBM(S) Continuous Torque Overview

Select from our wide variety of sizes and torque ranges to suit your application needs.

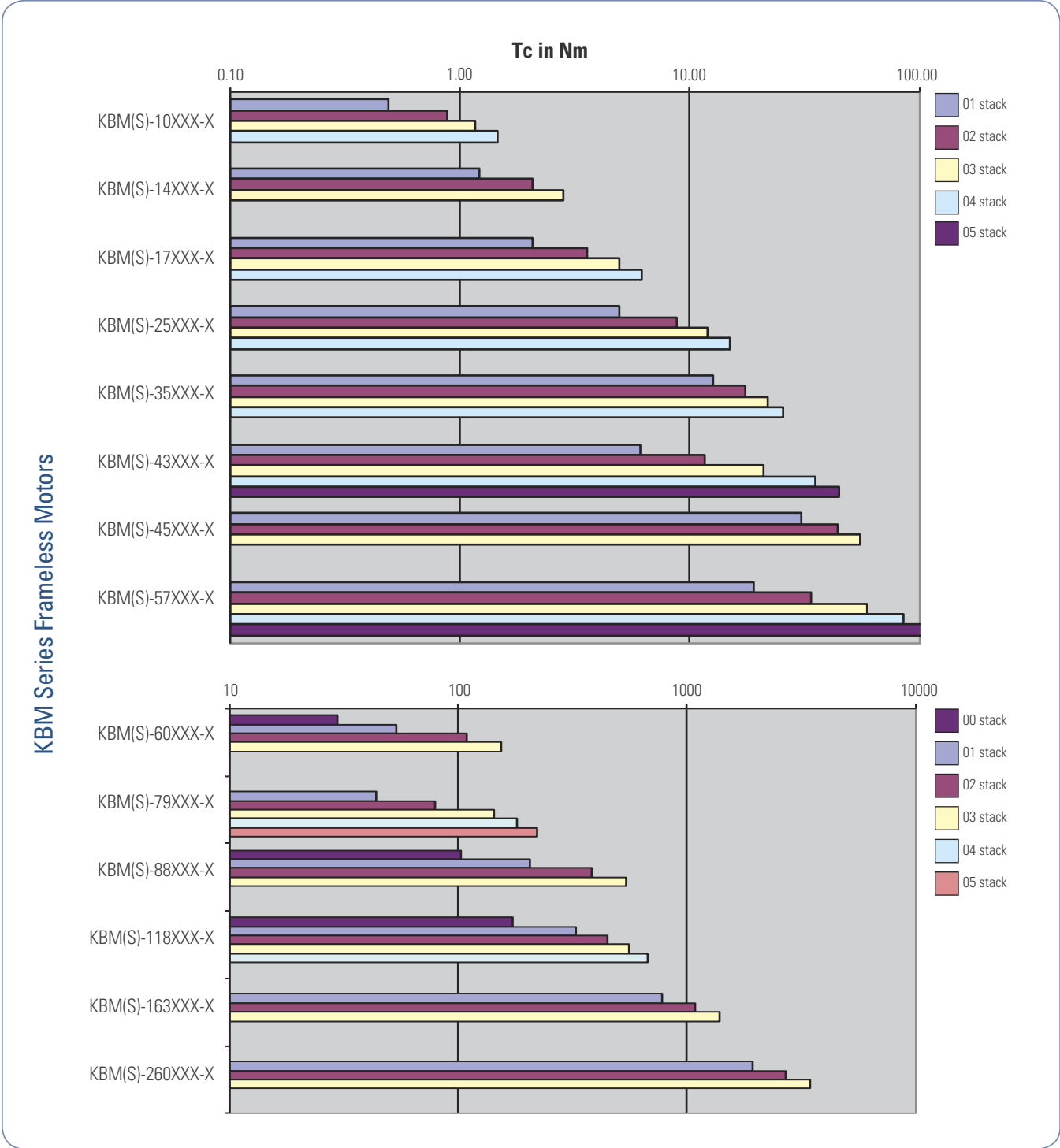

For more detailed information please visit: <http://www.kollmorgen.com/en-us/products/motors/direct-drive/kbm-series-frameless/>

KBM 10 Frameless Motors

The KBM(S)-10 series is designed to operate over a broad speed range with high acceleration. Designed for maximum torque density with minimal cogging by using a variable air gap, the KBM(S)-10 is an ideal choice to meet or exceed your compact frameless motor application needs.

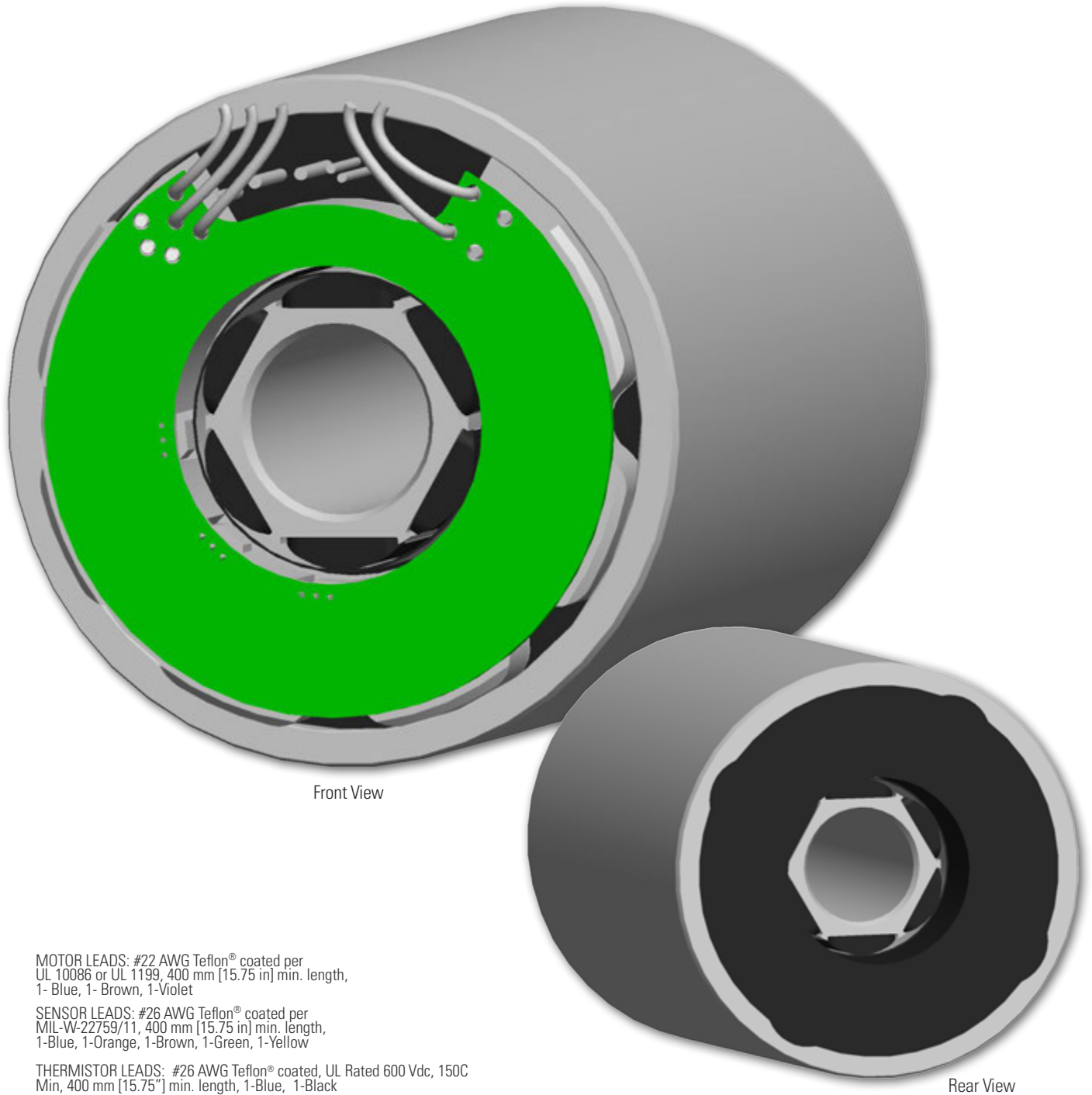

Front View

Rear View

MOTOR LEADS: #22 AWG Teflon[®] coated per UL 10086 or UL 1199, 400 mm [15.75 in] min. length, 1- Blue, 1- Brown, 1-Violet

SENSOR LEADS: #26 AWG Teflon[®] coated per MIL-W-22759/11, 400 mm [15.75 in] min. length, 1-Blue, 1-Orange, 1-Brown, 1-Green, 1-Yellow

THERMISTOR LEADS: #26 AWG Teflon[®] coated, UL Rated 600 Vdc, 150C Min, 400 mm [15.75"] min. length, 1-Blue, 1-Black

KBM 10 Outline Drawings

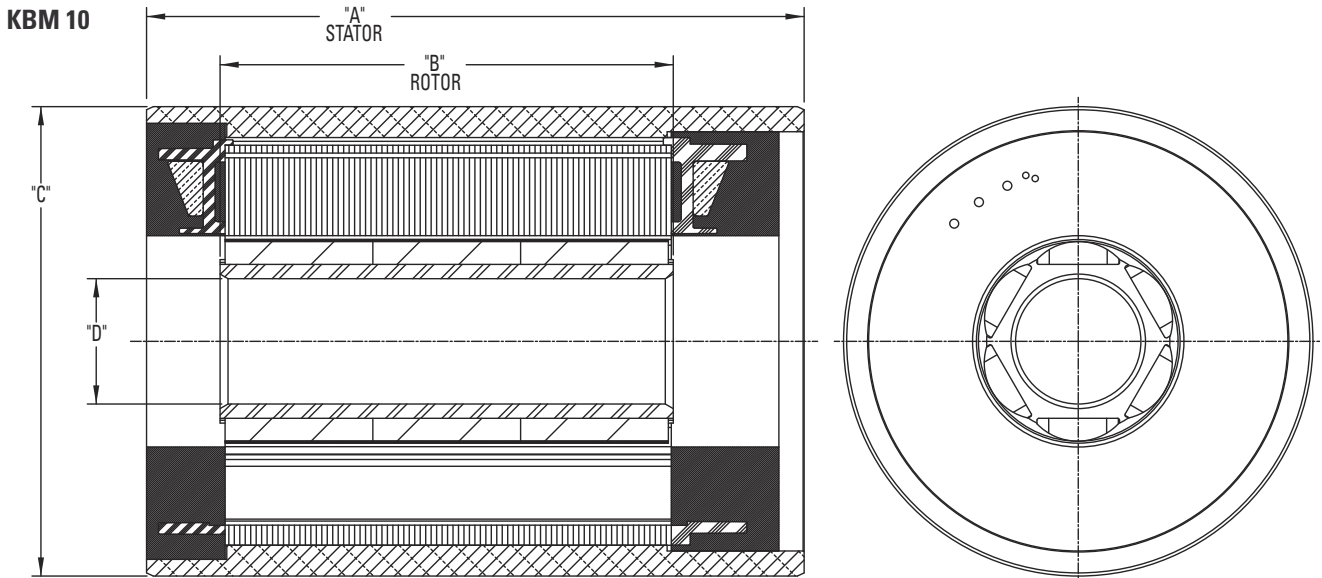

Model Number	"A" mm[inch]	"B" mm[inch]	Ø "C" mm[inch]	Ø "D" mm[inch]
KBM-10X01	46.00 [1.811]	20.14 [.793]	59.963 [2.3607]	16.009 [.6303]
KBM-10X02	65.00 [2.559]	39.02 [1.536]		
KBM-10X03	84.00 [3.307]	57.89 [2.279]		
KBM-10X04	103.00 [4.055]	76.77 [3.022]		

All dimensions are nominal. For more detailed and interactive 3D models with 2D product views, visit www.kollmorgen.com/kbm

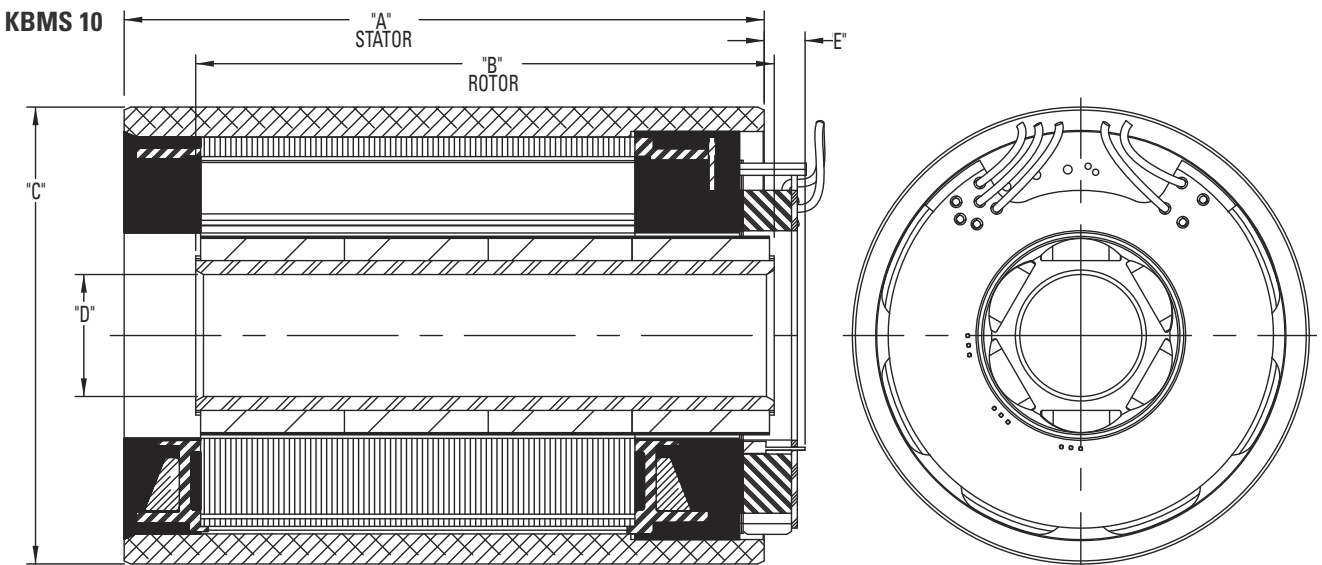

Model Number	"A" mm[inch]	"B" mm[inch]	Ø "C" mm[inch]	Ø "D" mm[inch]	"E" MAX mm[inch]
KBMS-10X01	46.00 [1.811]	38.17 [1.503]	59.963 [2.3607]	16.009 [.6303]	5.75 [.226]
KBMS-10X02	65.00 [2.559]	57.05 [2.246]			
KBMS-10X03	84.00 [3.307]	75.92 [2.989]			
KBMS-10X04	103.00 [4.055]	94.80 [3.732]			

All dimensions are nominal. For more detailed and interactive 3D models with 2D product views, visit www.kollmorgen.com/kbm

KBM 10 Performance Data

KBM(S)-10XXX Performance Data & Motor Parameters									
Motor Parameter	Symbol	Units	TOL	KBM(S)-10X01-X			KBM(S)-10X02-X		
				A	B	C	A	B	C
Continuous Stall Torque at 25°C Amb. (1)	Tc	Nm	NOM	0.487	0.509	0.492	0.876	0.899	0.868
		lb-ft		0.359	0.376	0.363	0.646	0.663	0.640
Continuous Current	Ic	Arms	NOM	1.73	3.37	5.21	1.53	3.00	5.14
Peak Stall Torque (25°C winding temp)	Tp	Nm	NOM	1.17	1.19	1.23	2.33	2.48	2.24
		lb-ft		0.860	0.880	0.910	1.72	1.83	1.65
Peak Current	Ip	Arms	NOM	4.33	8.70	13.8	4.33	8.65	15.5
Rated Continuous Output Power at 25°C Amb. (1)	P Rated	Watts		550	600	575	740	785	710
	HP Rated	HP		0.737	0.804	0.771	0.992	1.05	0.952
Speed at Rated Power	N Rated	RPM		15200	18500	18600	11000	15200	17000
Torque Sensitivity (2)	Kt	Nm / Arms	±10%	0.287	0.154	0.097	0.585	0.307	0.173
		lb-ft / Arms		0.212	0.114	0.071	0.431	0.227	0.127
Back EMF Constant	Kb	Vrms / kRPM	±10%	17.4	9.32	5.83	35.3	18.6	10.4
Motor Constant	Km	Nm/√watt	±10%	0.065	0.068	0.066	0.107	0.110	0.106
		lb-ft /√watt		0.048	0.050	0.048	0.079	0.081	0.078
Resistance (line to line)	Rm	Ohms	±10%	13.0	3.42	1.44	20.0	5.22	1.77
Inductance	Lm	mH		19	5.2	2.2	36	9.7	3.2
Inertia (KBM)	Jm	Kg-m ²		4.92E-6			1.03E-5		
		lb-ft-s ²		3.63E-6			7.60E-6		
Weight (KBM)	Wt	Kg		0.379			0.658		
		lb		0.835			1.45		
Inertia (KBMS)	Jm	Kg-m ²		1.03E-5			1.49E-5		
		lb-ft-s ²		7.56E-6			1.10E-5		
Weight (KBMS)	Wt	Kg		0.425			0.703		
		lb		0.936			1.55		
Max Static Friction	Tf	Nm		8.70E-3			1.63E-2		
		lb-ft		6.42E-3			1.20E-2		
Cogging Friction (peak-to-peak)	Tcog	Nm		7.20E-3			1.63E-2		
		lb-ft		5.31E-3			1.20E-2		
Viscous Damping	Fi	Nm/ kRPM		4.31E-3			5.17E-3		
		lb-ft / kRPM		3.18E-3			3.81E-3		
Thermal Resistance (3)	TPR	°C / watt		1.43			1.19		
Number of Poles	P	-		6			6		
Recommended Kollmorgen AKD Drive				00307	00606	00606	00307	00307	00606
Voltage Req'd at Rated Output	Vac Input	Vac		400	240	240	480	400	240
Peak Stall Torque (4) (Motor with Drive)	Tp Drive	Nm	±10%	1.17	1.19	1.23	2.33	2.48	2.24
		lb-ft		0.860	0.880	0.910	1.72	1.83	1.65
Cont. Stall Torque (4) (Motor with Drive)	Tc Drive	Nm	±10%	.487	.509	.492	.876	.899	.868
		lb-ft		.359	.376	.363	.646	.663	.640

- Notes: 1) Winding temperature = 155°C at continuous stall, at rated output, and for performance curves.
 2) To calculate no-load Kt and Kb at 25°C, multiply by 1.064.
 3) TPR assumes motor is housed and mounted to a 10" x 10" x 1/4" heat sink or equivalent.
 4) Peak & Continuous Torques may be limited by drive current, see www.kollmorgen.com for complete drive ratings.

KBM(S)-10XXX Performance Data & Motor Parameters											
Motor Parameter	Symbol	Units	TOL	KBM(S)-10X03-X				KBM(S)-10X04-X			
				A	B	C	D	A	B	C	D
Continuous Stall Torque at 25°C Amb. (1)	Tc	Nm	NOM	1.16	1.16	1.19	1.18	1.45	1.41	1.44	1.41
		lb-ft		0.854	0.859	0.880	0.870	1.07	1.04	1.06	1.04
Continuous Current	Ic	Arms	NOM	1.54	2.40	3.10	4.66	1.60	2.40	3.10	4.21
Peak Stall Torque (25°C winding temp)	Tp	Nm	NOM	3.46	3.53	3.58	3.69	4.66	4.75	4.80	4.91
		lb-ft		2.55	2.60	2.64	2.72	3.44	3.50	3.54	3.62
Peak Current	Ip	Arms	NOM	4.86	7.73	9.72	15.5	5.46	8.70	10.9	15.5
Rated Continuous Output Power at 25°C Amb. (1)	P Rated	Watts		780	740	725	850	820	860	835	910
	HP Rated	HP		1.05	0.992	0.972	1.14	1.10	1.15	1.12	1.22
Speed at Rated Power	N Rated	RPM		8500	14300	14500	13000	7050	11500	12000	9500
Torque Sensitivity (2)	Kt	Nm / Arms	±10%	0.767	0.498	0.399	0.259	0.930	0.603	0.480	0.345
		lb-ft / Arms		0.566	0.367	0.294	0.191	0.686	0.445	0.354	0.255
Back EMF Constant	Kb	Vrms / kRPM	±10%	46.4	30.1	24.1	15.7	56.2	36.4	29.0	20.9
Motor Constant	Km	Nm/√watt	±10%	0.136	0.137	0.140	0.138	0.168	0.164	0.168	0.164
		lb-ft/√watt		0.100	0.101	0.103	0.102	0.124	0.121	0.124	0.121
Resistance (line to line)	Rm	Ohms	±10%	21.2	8.77	5.44	2.34	20.4	9.02	5.44	2.94
Inductance	Lm	mH		41	17	11	4.7	44	19	12	6.2
Inertia (KBM)	Jm	Kg-m ²		1.55E-5				2.01E-5			
		lb-ft-s ²		1.14E-5				1.48E-5			
Weight (KBM)	Wt	Kg		0.943				1.22			
		lb		2.08				2.68			
Inertia (KBMS)	Jm	Kg-m ²		2.02E-5				2.55E-5			
		lb-ft-s ²		1.49E-5				1.88E-5			
Weight (KBMS)	Wt	Kg		0.990				1.26			
		lb		2.18				2.78			
Max Static Friction	Tf	Nm		2.22E-2				3.44E-2			
		lb-ft		1.64E-2				2.54E-2			
Cogging Friction (peak-to-peak)	Tcog	Nm		1.69E-2				2.44E-2			
		lb-ft		1.25E-2				1.80E-2			
Viscous Damping	Fi	Nm/ kRPM		6.10E-3				6.96E-3			
		lb-ft / kRPM		4.50E-3				5.13E-3			
Thermal Resistance (3)	TPR	°C / watt		1.10				1.07			
Number of Poles	P	-		6				6			
Recommended Kollmorgen AKD Drive				00307	00307	00607	00606	00307	00307	00607	00606
Voltage Req'd at Rated Output	Vac Input	Vac		480	480	400	240	480	480	400	240
Peak Stall Torque (5) (Motor with Drive)	Tp Drive	Nm	±10%	3.46	3.53	3.58	3.69	4.66	4.75	4.80	4.91
		lb-ft		2.55	2.60	2.64	2.72	3.44	3.50	3.54	3.62
Cont. Stall Torque (4) (Motor with Drive)	Tc Drive	Nm	±10%	1.16	1.16	1.19	1.18	1.45	1.41	1.44	1.41
		lb-ft		.854	.859	.880	.870	1.07	1.04	1.06	1.04

- Notes: 1) Winding temperature = 155°C at continuous stall, at rated output, and for performance curves.
2) To calculate no-load Kt and Kb at 25°C, multiply by 1.064.
3) TPR assumes motor is housed and mounted to a 10" x 10" x 1/4" heat sink or equivalent.
4) Peak & Continuous Torques may be limited by drive current, see www.kollmorgen.com for complete drive ratings.

KBM 10 Performance Curves

Continuous duty capability for 130°C rise in a 25°C ambient using recommended AKD servo drive and sinusoidal commutation.

**KBM(S)-10X01
Continuous Torque**

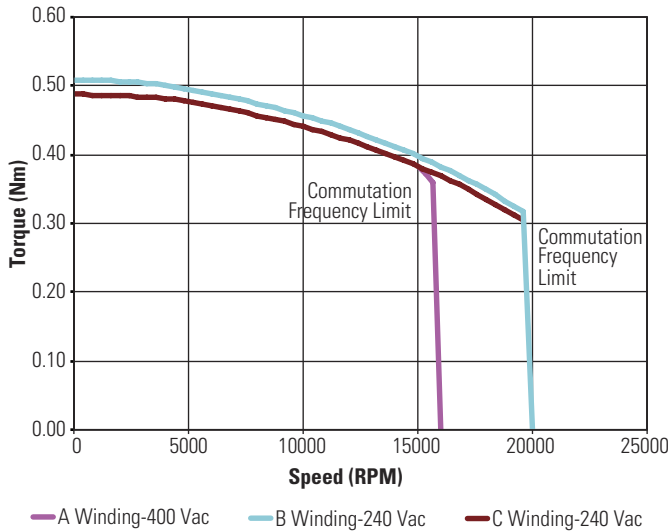

**KBM(S)-10X02
Continuous Torque**

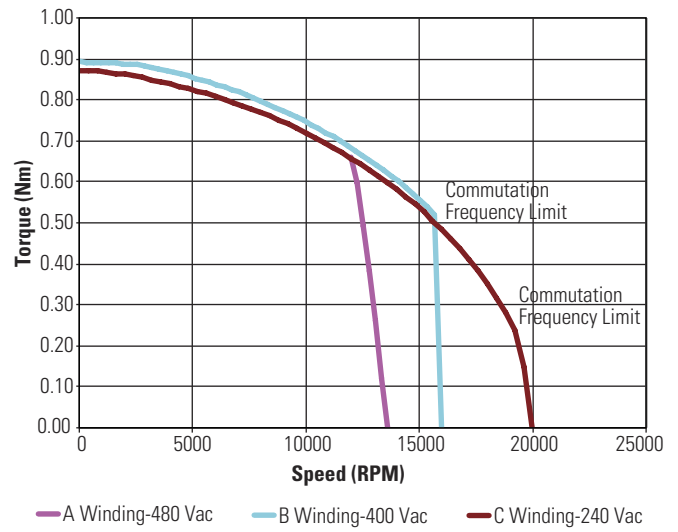

**KBM(S)-10X03
Continuous Torque**

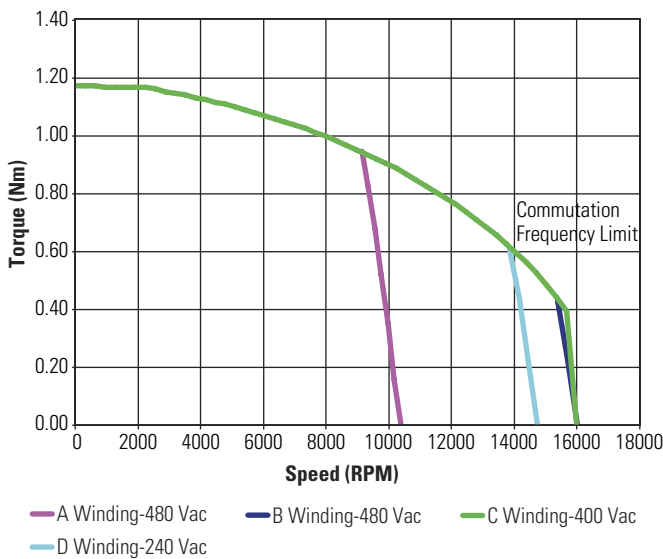

**KBM(S)-10X04
Continuous Torque**

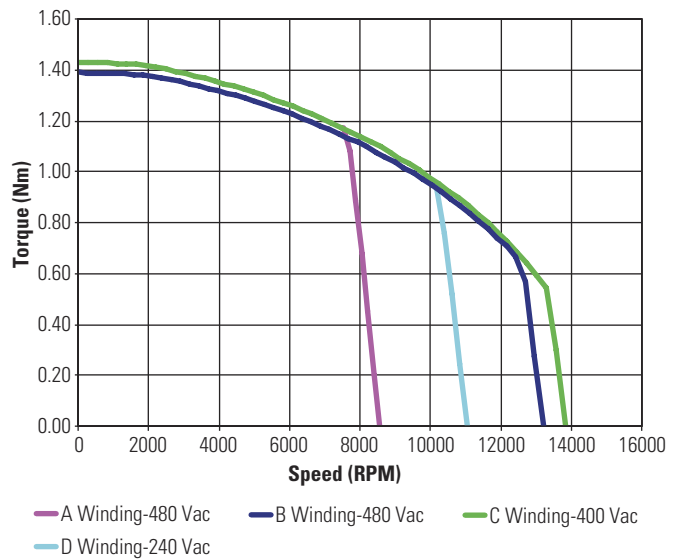

Low Voltage optimized windings available.

Notes

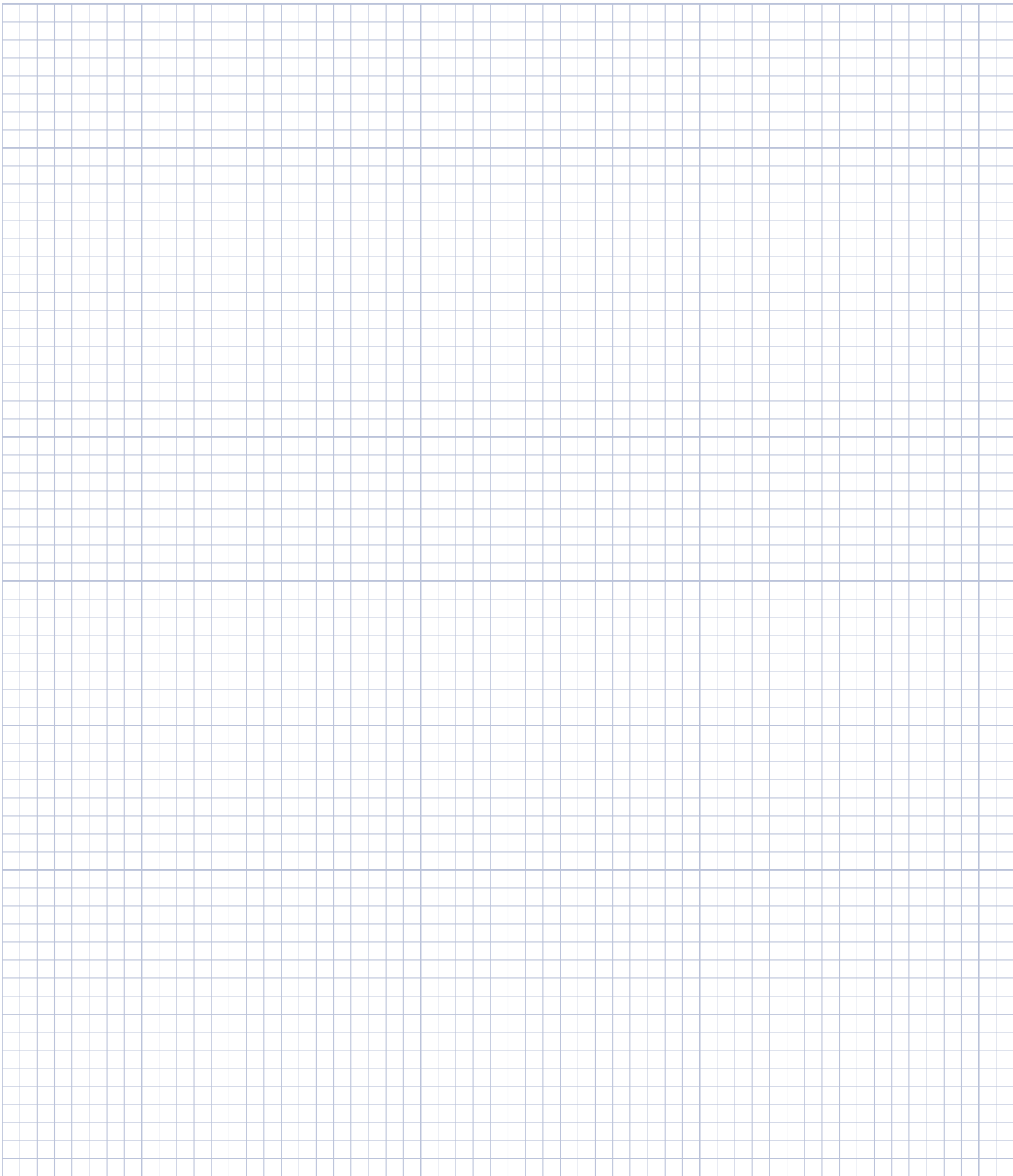

KBM 14 Frameless Motors

K B M 1 4

The KBM(S)-14 series is designed to operate over a broad speed range with high acceleration. Designed for maximum torque density with minimal cogging by using a variable air gap, the KBM(S)-14 is an ideal choice to meet or exceed your compact frameless motor application needs.

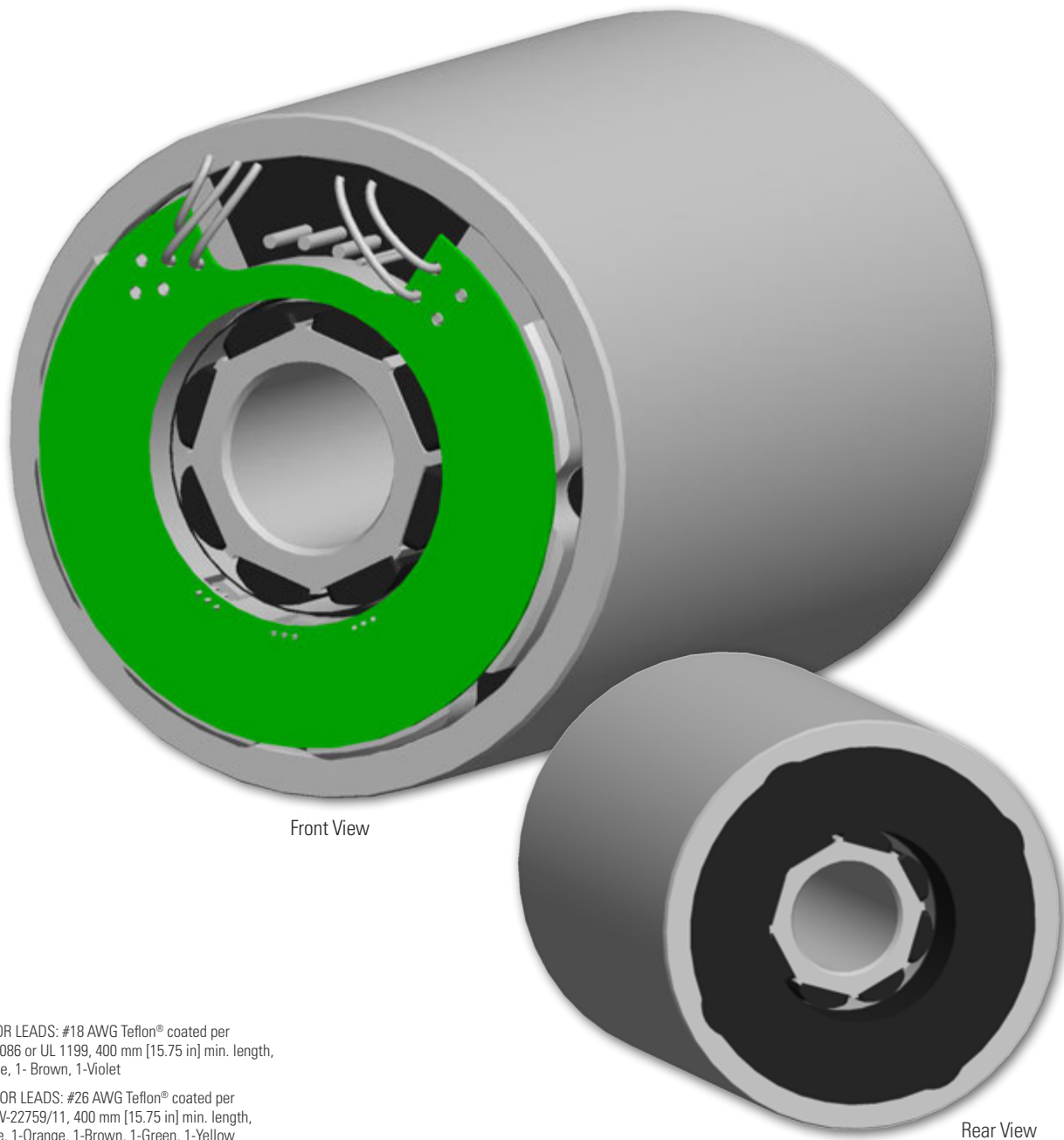

MOTOR LEADS: #18 AWG Teflon® coated per UL 10086 or UL 1199, 400 mm [15.75 in] min. length, 1-Blue, 1-Brown, 1-Violet

SENSOR LEADS: #26 AWG Teflon® coated per MIL-W-22759/11, 400 mm [15.75 in] min. length, 1-Blue, 1-Orange, 1-Brown, 1-Green, 1-Yellow

THERMISTOR LEADS: #26 AWG Teflon® coated, UL Rated 600 Vdc, 150C Min, 400 mm [15.75"] min. length, 1-Blue, 1-Black

KBM 14 Outline Drawings

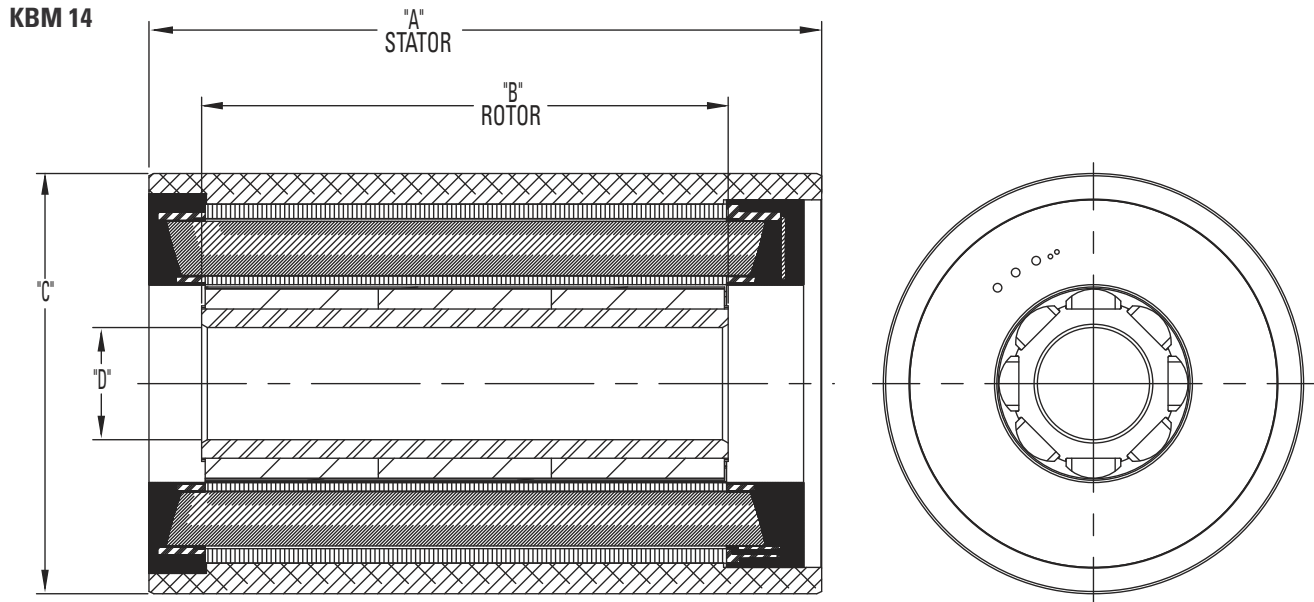

Model Number	"A" mm[inch]	"B" mm[inch]	Ø "C" mm[inch]	Ø "D" mm[inch]
KBM-14X01	58.00 [2.283]	32.16 [1.266]	74.963 [2.9513]	20.010 [0.7878]
KBM-14X02	89.00 [3.504]	63.04 [2.482]		
KBM-14X03	120.00 [4.724]	93.93 [3.698]		

All dimensions are nominal. For more detailed and interactive 3D models with 2D product views, visit www.kollmorgen.com/kbm

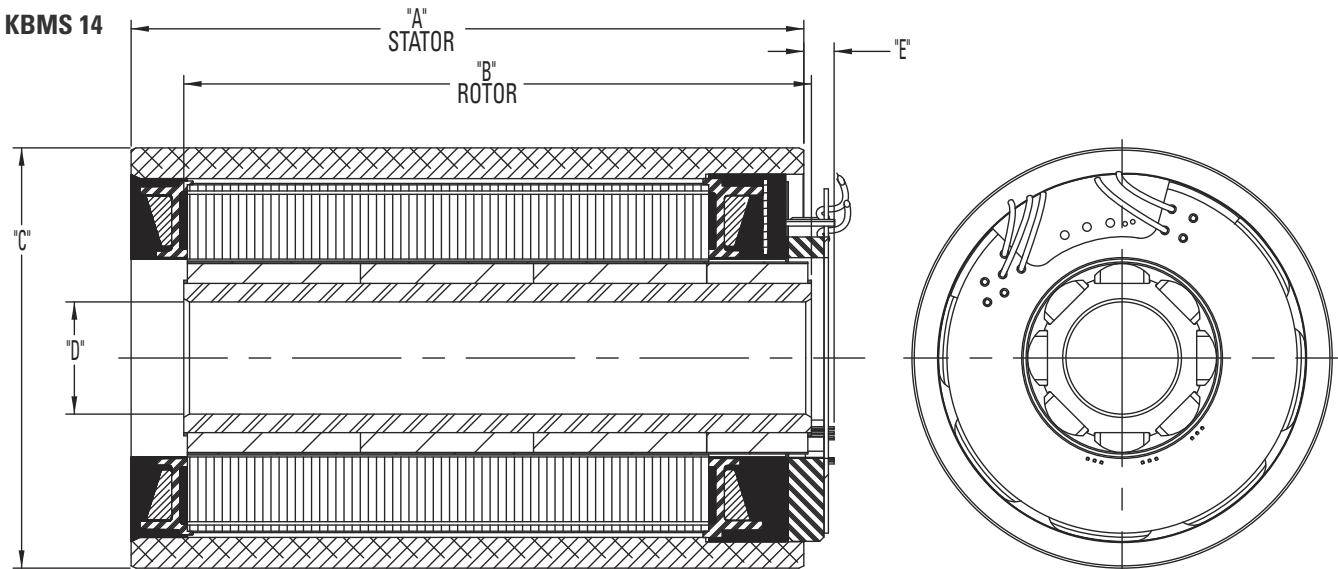

Model Number	"A" mm[inch]	"B" mm[inch]	Ø "C" mm[inch]	Ø "D" mm[inch]	"E" MAX mm[inch]
KBMS-14X01	58.00 [2.283]	50.19 [1.976]	74.963 [2.9513]	20.010 [0.7878]	5.75 [0.226]
KBMS-14X02	89.00 [3.504]	81.08 [3.192]			
KBMS-14X03	120.00 [4.724]	111.96 [4.408]			

All dimensions are nominal. For more detailed and interactive 3D models with 2D product views, visit www.kollmorgen.com/kbm

KBM 14 Performance Data

KBM(S)-14XXX PERFORMANCE DATA & MOTOR PARAMETERS															
Motor Parameter	Symbol	Units	TOL	KBM(S)-14X01-X			KBM(S)-14X02-X				KBM(S)-14X03-X				
				A	B	C	A	B	C	D	A	B	C		
Continuous Stall Torque at 25°C Amb. (1)	Tc	Nm	NOM	1.22	1.25	1.21	2.08	2.08	2.11	2.17	2.82	2.87	2.92		
		lb-ft		0.897	0.919	0.890	1.53	1.53	1.56	1.60	2.08	2.12	2.15		
Continuous Current	Ic	Arms	NOM	1.53	3.25	6.25	1.59	2.42	3.10	5.97	1.64	2.81	6.04		
Peak Stall Torque (25°C winding temp)	Tp	Nm	NOM	3.28	3.43	3.59	6.67	6.83	6.98	7.31	10.1	10.5	10.5		
		lb-ft		2.42	2.53	2.65	4.92	5.04	5.15	5.39	7.46	7.72	7.76		
Peak Current	Ip	Arms	NOM	4.32	9.63	19.4	5.39	8.57	10.9	21.8	6.12	10.9	24.5		
Rated Continuous Output Power at 25°C Amb. (1)	P Rated	Watts		735	700	915	845	1000	585	1000	975	875	1215	1175	1230
	HP Rated	HP		0.986	0.956	1.22	1.13	1.35	0.786	1.34	1.30	1.18	1.63	1.58	1.65
Speed at Rated Power	N Rated	RPM		7950	12000	13500	4900	7700	10250	8000	8900	3600	6500	5225	6600
Torque Sensitivity (2)	Kt	Nm / Arms	+/-10%	0.815	0.394	0.199	1.34	0.882	0.699	0.374	1.78	1.05	0.498		
		lb-ft / Arms		0.601	0.290	0.147	0.990	0.650	0.516	0.276	1.31	0.776	0.367		
Back EMF Constant	Kb	Vrms / kRPM	+/- 10%	49.3	23.8	12.0	81.1	53.3	42.3	22.6	107.4	63.7	30.1		
Motor Constant	Km	Nm/√watt	+/-10%	0.144	0.148	0.143	0.225	0.224	0.227	0.235	2.79	2.79	2.87		
		lb-ft /√watt		0.106	0.109	0.106	0.166	0.165	0.168	0.173	2.06	2.06	2.12		
Resistance (line to line)	Rm	Ohms	+/- 10%	21.4	4.74	1.29	23.8	10.3	6.30	1.69	26.6	9.01	1.96		
Inductance	Lm	mH		38	8.6	2.4	47	20	13	3.6	54	19	4.1		
Inertia (KBM)	Jm	Kg-m ²		2.41E-5			4.88E-5				7.31E-5				
		lb-ft-s ²		1.78E-5			3.60E-5				5.39E-5				
Weight (KBM)	Wt	Kg		0.898			1.59				2.98				
		lb		1.98			3.50				6.58				
Inertia (KBMS)	Jm	Kg-m ²		3.36E-5			5.56E-5				8.81E-5				
		lb-ft-s ²		2.48E-5			4.10E-5				6.50E-5				
Weight (KBMS)	Wt	Kg		1.00			1.68				3.08				
		lb		2.20			3.70				6.78				
Max Static Friction	Tf	Nm		2.71E-2			4.75E-2				7.73E-2				
		lb-ft		2.00E-2			3.50E-2				5.70E-2				
Cogging Friction (peak-to-peak)	Tcog	Nm		1.72E-2			3.25E-2				5.78E-2				
		lb-ft		1.27E-2			2.40E-2				4.26E-2				
Viscous Damping	Fi	Nm/ kRPM		1.88E-3			2.82E-3				3.76E-3				
		lb-ft / kRPM		1.39E-3			2.08E-3				2.77E-3				
Thermal Resistance (3)	TPR	°C / watt		1.11			0.920				0.780				
Number of Poles	P	-		8			8				8				
Recommended Kollmorgen AKD Drive				00307	00607	01206	00307	00307	00607	01206	00307	00307	01206		
Voltage Req'd at Rated Output	Vac Input	Vac		480	400	240	480	480	480	400	240	480	480	400	240
Peak Stall Torque (4) (Motor with Drive)	Tp Drive	Nm	+/- 10%	3.28	3.43	3.59	6.67	6.83	6.98	6.98	7.31	10.11	8.90	8.90	10.5
		lb-ft		2.42	2.53	2.65	4.92	5.04	5.15	5.15	5.39	7.46	6.56	6.56	7.76
Cont. Stall Torque (4) (Motor with Drive)	Tc Drive	Nm	+/- 10%	1.22	1.25	1.21	2.08	2.08	2.11	2.11	2.17	2.82	2.87	2.87	2.92
		lb-ft		0.897	0.919	0.890	1.53	1.53	1.56	1.56	1.60	2.08	2.12	2.12	2.15

- Notes
- 1) Winding temperature = 155°C at continuous stall, at rated output, and for performance curves.
 - 2) To calculate no-load Kt and Kb at 25°C, multiply by 1.064.
 - 3) TPR assumes motor is housed and mounted to a 10" x 10" x 1/4" heat sink or equivalent.
 - 4) Peak & Continuous Torques may be limited by drive current, see www.kollmorgen.com for complete drive ratings.

KBM 14 Performance Curves

Continuous duty capability for 130°C rise in a 25°C ambient using recommended AKD servo drive and sinusoidal commutation.

**KBM(S)-14X01
Continuous Torque**

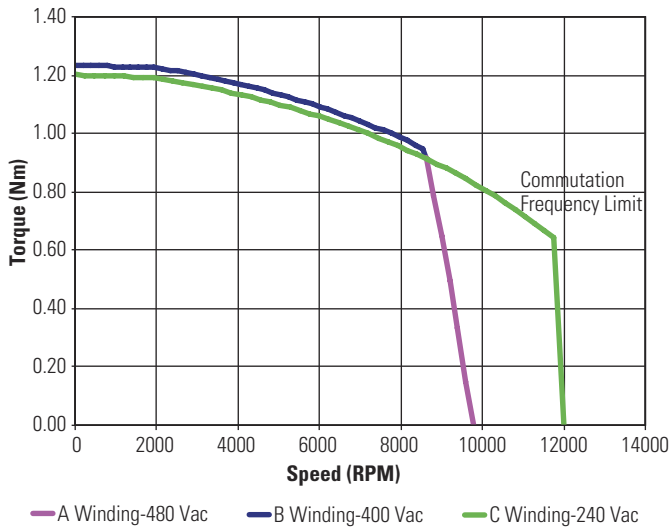

**KBM(S)-14X02
Continuous Torque**

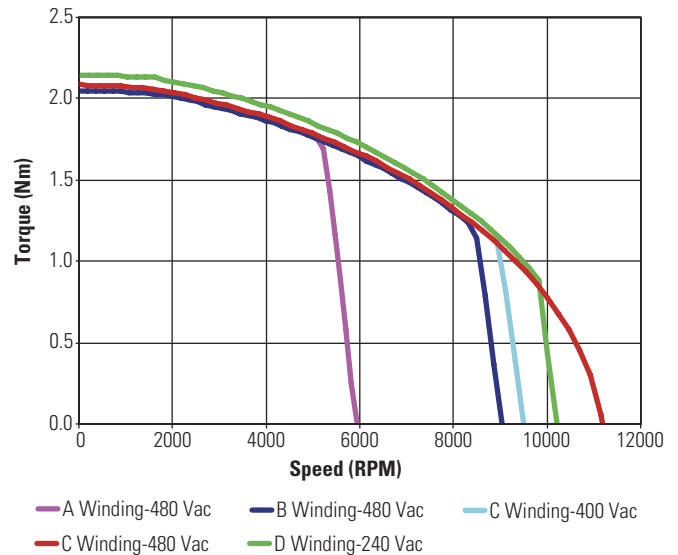

**KBM(S)-14X03
Continuous Torque**

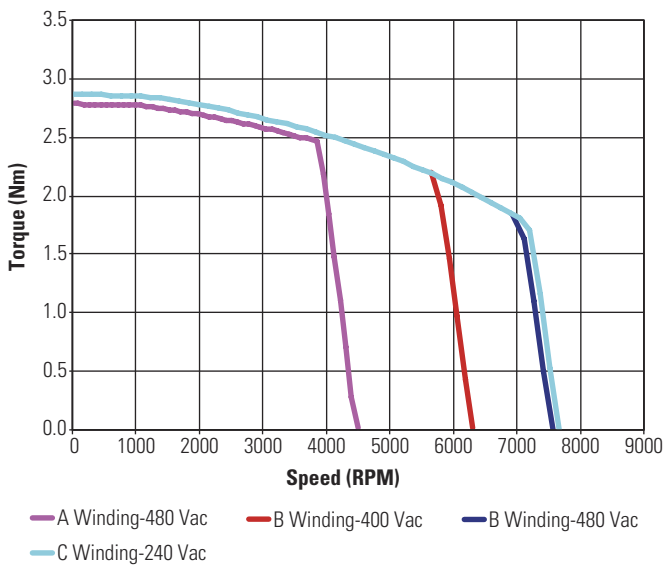

Low Voltage optimized windings available.

KBM 17 Frameless Motors

K B M 1 7

The KBM(S)-17 series is designed to operate over a broad speed range with high acceleration. Designed for maximum torque density with minimal cogging by using a variable air gap, the KBM(S)-17 is an ideal choice to meet or exceed your compact frameless motor application needs.

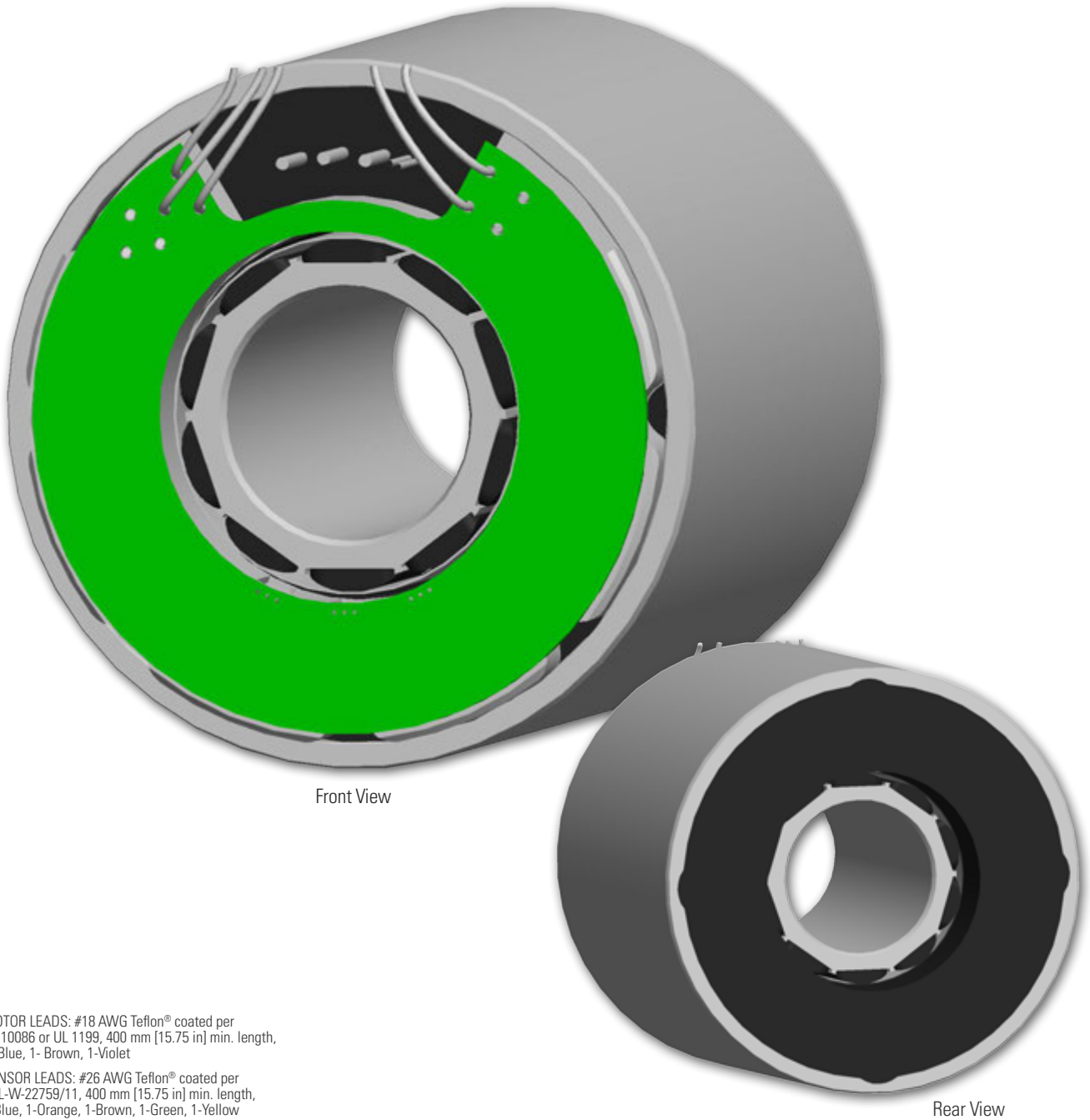

MOTOR LEADS: #18 AWG Teflon® coated per UL 10086 or UL 1199, 400 mm [15.75 in] min. length, 1- Blue, 1- Brown, 1-Violet

SENSOR LEADS: #26 AWG Teflon® coated per MIL-W-22759/11, 400 mm [15.75 in] min. length, 1-Blue, 1-Orange, 1-Brown, 1-Green, 1-Yellow

THERMISTOR LEADS: #26 AWG Teflon® coated, UL Rated 600 Vdc, 150C Min, 400 mm [15.75"] min. length, 1-Blue, 1-Black

KBM 17 Outline Drawings

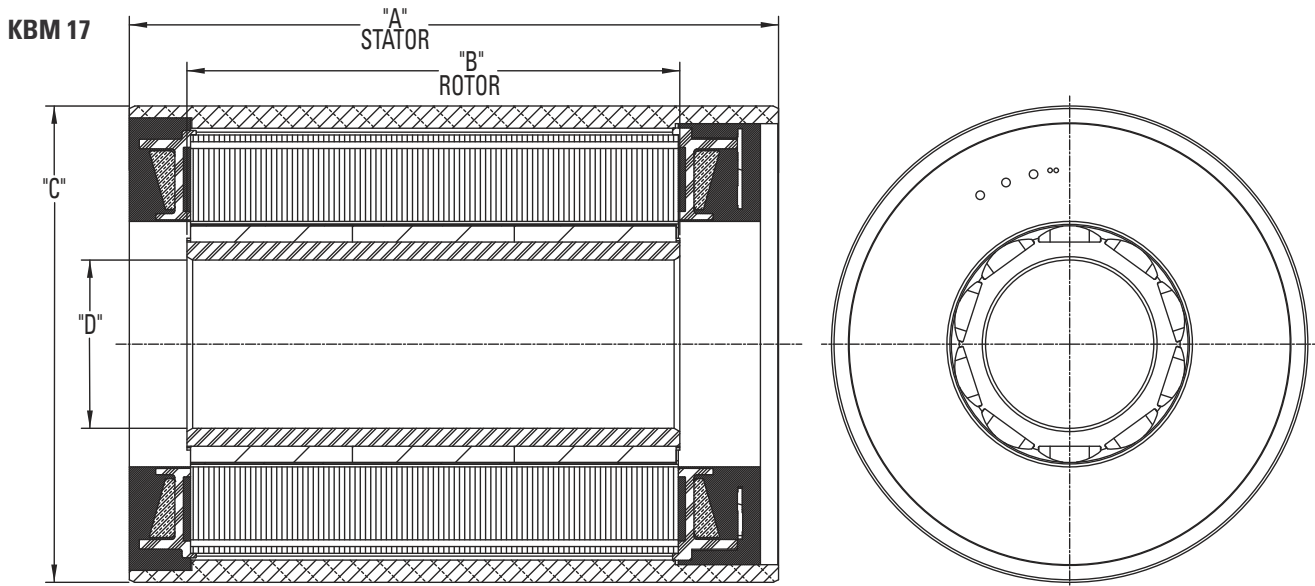

Model Number	"A" mm[inch]	"B" mm[inch]	Ø "C" mm[inch]	Ø "D" mm[inch]
KBM-17X01	57.80 [2.276]	30.15 [1.187]	84.963 [3.345]	30.010 [1.1815]
KBM-17X02	86.80 [3.417]	59.03 [2.324]		
KBM-17X03	115.80 [4.559]	87.91 [3.461]		
KBM-17X04	144.80 [5.701]	116.79 [4.598]		

All dimensions are nominal. For more detailed and interactive 3D models with 2D product views, visit www.kollmorgen.com/kbm

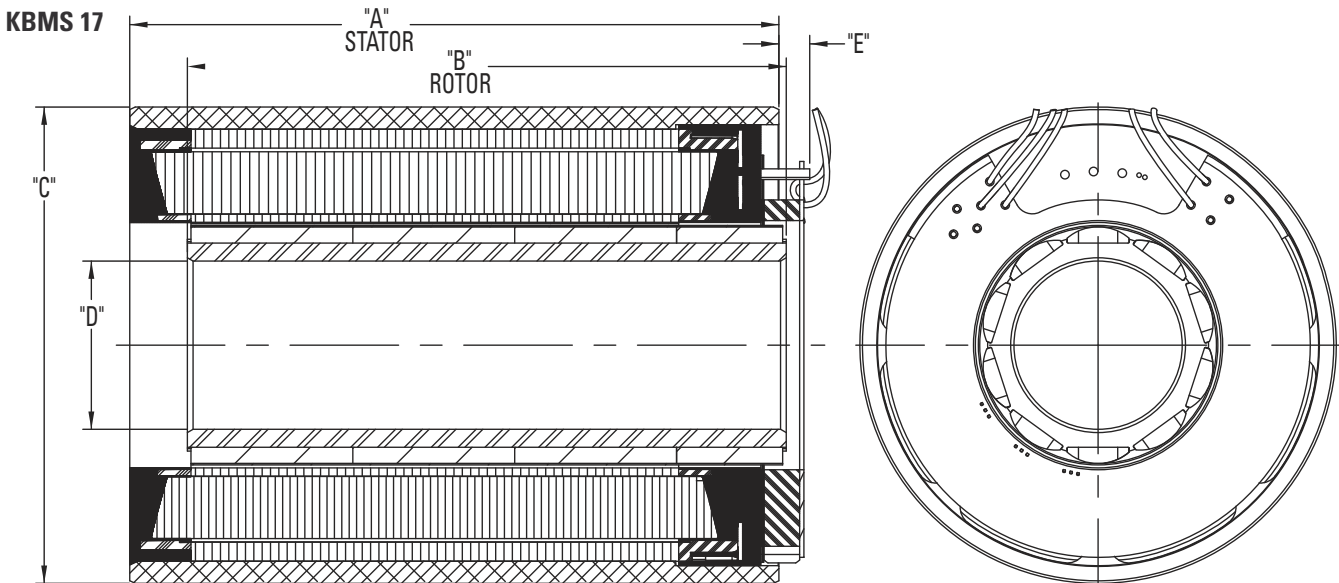

Model Number	"A" mm[inch]	"B" mm[inch]	Ø "C" mm[inch]	Ø "D" mm[inch]	"E" MAX mm[inch]
KBMS-17X01	57.80 [2.276]	49.07 [1.932]	84.963 [3.345]	30.010 [1.1815]	5.75 [.226]
KBMS-17X02	86.80 [3.417]	77.95 [3.069]			
KBMS-17X03	115.80 [4.559]	106.83 [4.206]			
KBMS-17X04	144.80 [5.701]	135.71 [5.353]			

All dimensions are nominal. For more detailed and interactive 3D models with 2D product views, visit www.kollmorgen.com/kbm

KBM 17 Performance Data

KBM(S)-17XXX PERFORMANCE DATA & MOTOR PARAMETERS											
Motor Parameter	Symbol	Units	TOL	KBM(S)-17X01-X			KBM(S)-17X02-X				
				A	B	C	A	B	C	D	
Continuous Stall Torque at 25°C Amb. (1)	Tc	Nm	NOM	2.08	2.06	2.07	3.58	3.52	3.57	3.58	
		lb-ft		1.53	1.52	1.53	2.64	2.60	2.64	2.64	
Continuous Current	Ic	Arms	NOM	1.65	3.11	6.10	1.59	3.00	5.27	6.25	
Peak Stall Torque (25°C winding temp)	Tp	Nm	NOM	5.95	6.14	6.35	12.2	12.3	12.7	12.8	
		lb-ft		4.39	4.53	4.68	9.00	9.05	9.38	9.45	
Peak Current	Ip	Arms	NOM	5.45	10.9	21.8	6.08	12.2	21.9	24.5	
Rated Continuous Output Power at 25°C Amb. (1)	P Rated	Watts		810	715	955	855	835	1270	790	1290
	HP Rated	HP		1.09	0.958	1.280	1.15	1.12	1.70	1.06	1.73
Speed at Rated Power	N Rated	RPM		4650	9600	8125	9050	2600	5450	7560	5600
Torque Sensitivity (2)	Kt	Nm / Arms	+/-10%	1.29	0.681	0.355	2.31	1.21	0.709	0.565	
		lb-ft / Arms		0.948	0.502	0.262	1.70	0.890	0.523	0.416	
Back EMF Constant	Kb	Vrms / kRPM	+/- 10%	77.7	41.2	21.5	139.6	73.0	42.9	34.1	
Motor Constant	Km	Nm/√watt	+/-10%	0.227	0.227	0.232	0.359	0.353	0.365	0.359	
		lb-ft /√watt		0.168	0.167	0.171	0.265	0.261	0.270	0.265	
Resistance (line to line)	Rm	Ohms	+/- 10%	21.3	6.02	1.56	27.5	7.78	2.51	1.65	
Inductance	Lm	mH		66	18	5.0	97	27	9.2	6.0	
Inertia (KBM)	Jm	Kg-m ²		5.12E-5			9.54E-5				
		lb-ft-s ²		3.78E-5			7.04E-5				
Weight (KBM)	Wt	Kg		1.05			1.87				
		lb		2.31			4.12				
Inertia (KBMS)	Jm	Kg-m ²		8.62E-5			1.28E-4				
		lb-ft-s ²		6.36E-5			9.45E-5				
Weight (KBMS)	Wt	Kg		1.16			1.97				
		lb		2.55			4.35				
Max Static Friction	Tf	Nm		4.23E-2			7.59E-2				
		lb-ft		3.12E-2			5.60E-2				
Cogging Friction (peak-to-peak)	Tcog	Nm		3.19E-2			5.61E-2				
		lb-ft		2.35E-2			4.14E-2				
Viscous Damping	Fi	Nm/ kRPM		8.45E-3			1.22E-2				
		lb-ft / kRPM		6.23E-3			9.00E-3				
Thermal Resistance (3)	TPR	°C / watt		0.970			0.800				
Number of Poles	P	-		10			10				
Recommended Kollmorgen AKD Drive				00307	00607	01206	00307	00307	00607	01206	
Voltage Req'd at Rated Output	Vac Input	Vac		480	480	400	240	480	480	400	240
Peak Stall Torque (4) (Motor with Drive)	Tp Drive	Nm	+/-10%	5.95	6.14	6.14	6.35	12.2	9.61	11.0	12.8
		lb-ft		4.39	4.53	4.53	4.68	9.00	7.08	8.11	9.45
Cont. Stall Torque (4) (Motor with Drive)	Tc Drive	Nm	+/-10%	2.08	2.06	2.06	2.07	3.58	3.52	3.57	3.58
		lb-ft		1.53	1.52	1.52	1.53	2.64	2.60	2.64	2.64

* Notes 1) Winding temperature = 155°C at continuous stall, at rated output, and for performance curves.
 2) To calculate no-load Kt and Kb at 25°C, multiply by 1.064.
 3) TPR assumes motor is housed and mounted to a 10" x 10" x 1/4" heat sink or equivalent.
 4) Peak & Continuous Torques may be limited by drive current, see www.kollmorgen.com for complete drive ratings.

KBM(S)-17XXX PERFORMANCE DATA & MOTOR PARAMETERS											
Motor Parameter	Symbol	Units	TOL	KBM(S)-17X03-X				KBM(S)-17X04-X			
				A	B	C	D	A	B	C	D
Continuous Stall Torque at 25°C Amb. (1)	Tc	Nm	NOM	4.89	4.90	5.00	5.00	6.20	6.12	5.90	5.90
		lb-ft		3.61	3.62	3.69	3.69	4.57	4.52	4.35	4.35
Continuous Current	Ic	Arms	NOM	3.02	5.32	6.14	10.4	3.26	5.53	6.20	9.56
Peak Stall Torque (25°C winding temp)	Tp	Nm	NOM	18.5	18.8	18.8	19.0	23.7	23.7	23.7	24.0
		lb-ft		13.6	13.9	13.9	14.0	17.5	17.5	17.5	17.7
Peak Current	Ip	Arms	NOM	13.8	24.4	27.2	48.0	14.5	25.0	28.1	44.0
Rated Continuous Output Power at 25°C Amb. (1)	P Rated	Watts		1440	890	965	1275	1520	1075	975	1550
	HP Rated	HP		1.93	1.19	1.29	1.71	2.04	1.44	1.31	2.08
Speed at Rated Power	N Rated	RPM		3950	6500	6480	6100	3350	5700	5775	5000
Torque Sensitivity (2)	Kt	Nm / Arms	+/-10%	1.66	0.948	0.849	0.496	1.96	1.14	1.01	0.661
		lb-ft / Arms		1.22	0.699	0.626	0.366	1.45	0.841	0.748	0.487
Back EMF Constant	Kb	Vrms / kRPM	+/- 10%	100.2	57.3	51.3	30.0	118.5	69.0	61.3	40.0
Motor Constant	Km	Nm/√watt	+/-10%	0.461	0.462	0.478	0.471	0.544	0.557	0.555	0.557
		lb-ft /√watt		0.340	0.341	0.353	0.348	0.401	0.411	0.409	0.411
Resistance (line to line)	Rm	Ohms	+/- 10%	8.61	2.81	2.10	0.740	8.64	2.80	2.23	0.940
Inductance	Lm	mH		33	11	8.8	2.9	34	12	9.1	3.8
Inertia (KBM)	Jm	Kg-m ²		1.42E-4				2.03E-4			
		lb-ft-s ²		1.05E-4				1.50E-4			
Weight (KBM)	Wt	Kg		2.65				3.62			
		lb		5.85				7.98			
Inertia (KBMS)	Jm	Kg-m ²		1.75E-4				2.40E-4			
		lb-ft-s ²		1.29E-4				1.77E-4			
Weight (KBMS)	Wt	Kg		2.76				3.72			
		lb		6.08				8.20			
Max Static Friction	Tf	Nm		.130				.165			
		lb-ft		9.60E-2				.122			
Cogging Friction (peak-to-peak)	Tcog	Nm		.102				.127			
		lb-ft		7.50E-2				9.40E-2			
Viscous Damping	Fi	Nm/ kRPM		1.60E-2				1.98E-2			
		lb-ft / kRPM		1.18E-2				1.46E-2			
Thermal Resistance (3)	TPR	°C / watt		0.700				0.650			
Number of Poles	P	-		10				10			
Recommended Kollmorgen AKD Drive				00607	00607	01207	01206	00607	00607	01207	01206
Voltage Req'd at Rated Output	Vac Input	Vac		480	480	400	240	480	480	400	240
Peak Stall Torque (4) (Motor with Drive)	Tp Drive	Nm	+/-10%	18.5	14.6	18.8	13.7	23.7	18.5	23.7	17.7
		lb-ft		13.6	10.8	13.9	10.1	17.5	13.6	17.5	13.0
Cont. Stall Torque (4) (Motor with Drive)	Tc Drive	Nm	+/-10%	4.89	4.90	5.00	5.00	6.20	6.12	5.90	5.90
		lb-ft		3.61	3.62	3.69	3.69	4.57	4.52	4.35	4.35

- * Notes 1) Winding temperature = 155°C at continuous stall, at rated output, and for performance curves.
2) To calculate no-load Kt and Kb at 25°C, multiply by 1.064.
3) TPR assumes motor is housed and mounted to a 10" x 10" x 1/4" heat sink or equivalent.
4) Peak & Continuous Torques may be limited by drive current, see www.kollmorgen.com for complete drive ratings.

KBM 17 Performance Curves

Continuous duty capability for 130°C rise in a 25°C ambient using recommended AKD servo drive and sinusoidal commutation.

**KBM(S)-17X01
Continuous Torque**

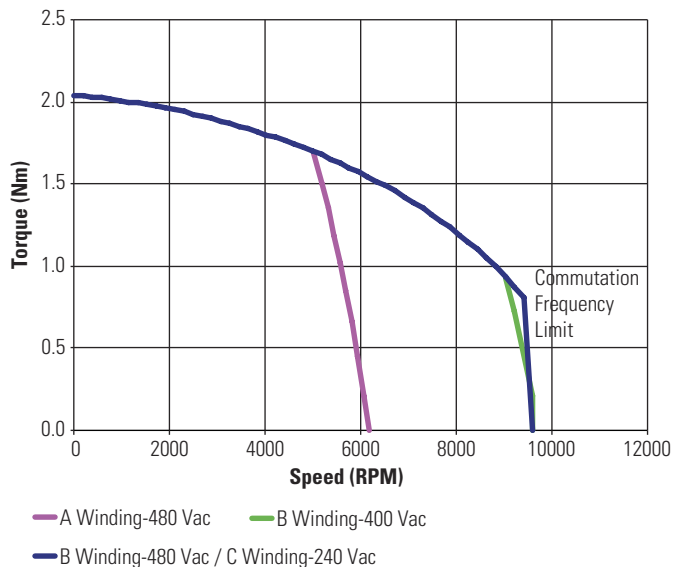

**KBM(S)-17X02
Continuous Torque**

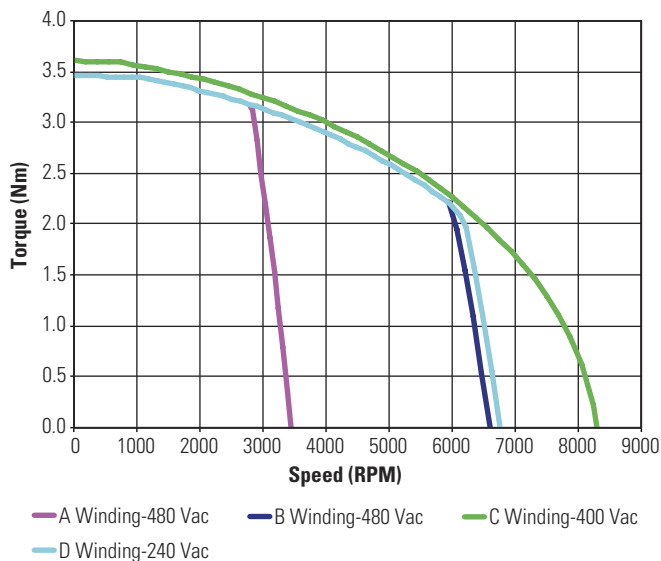

**KBM(S)-17X03
Continuous Torque**

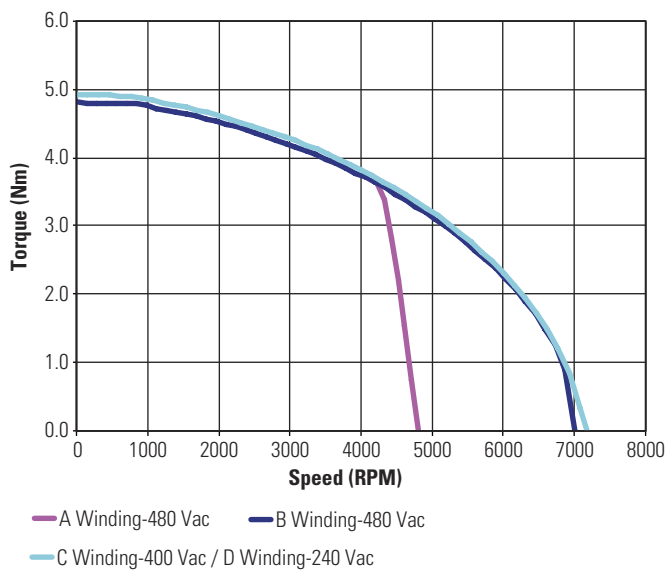

**KBM(S)-17X04
Continuous Torque**

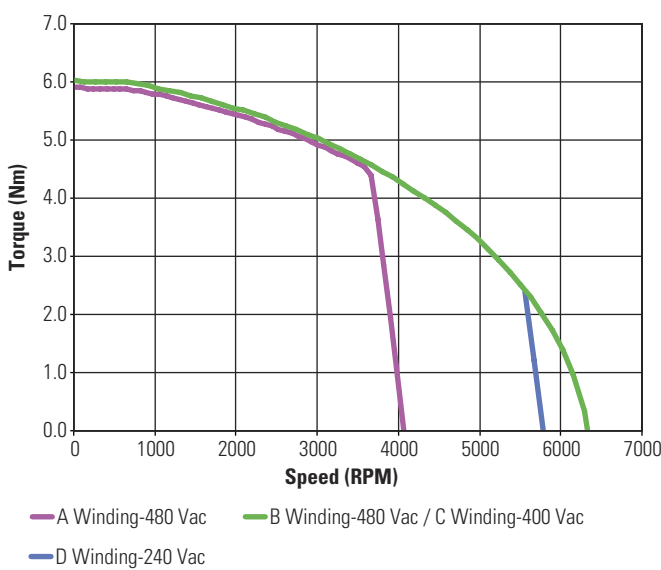

Low Voltage optimized windings available.

Notes

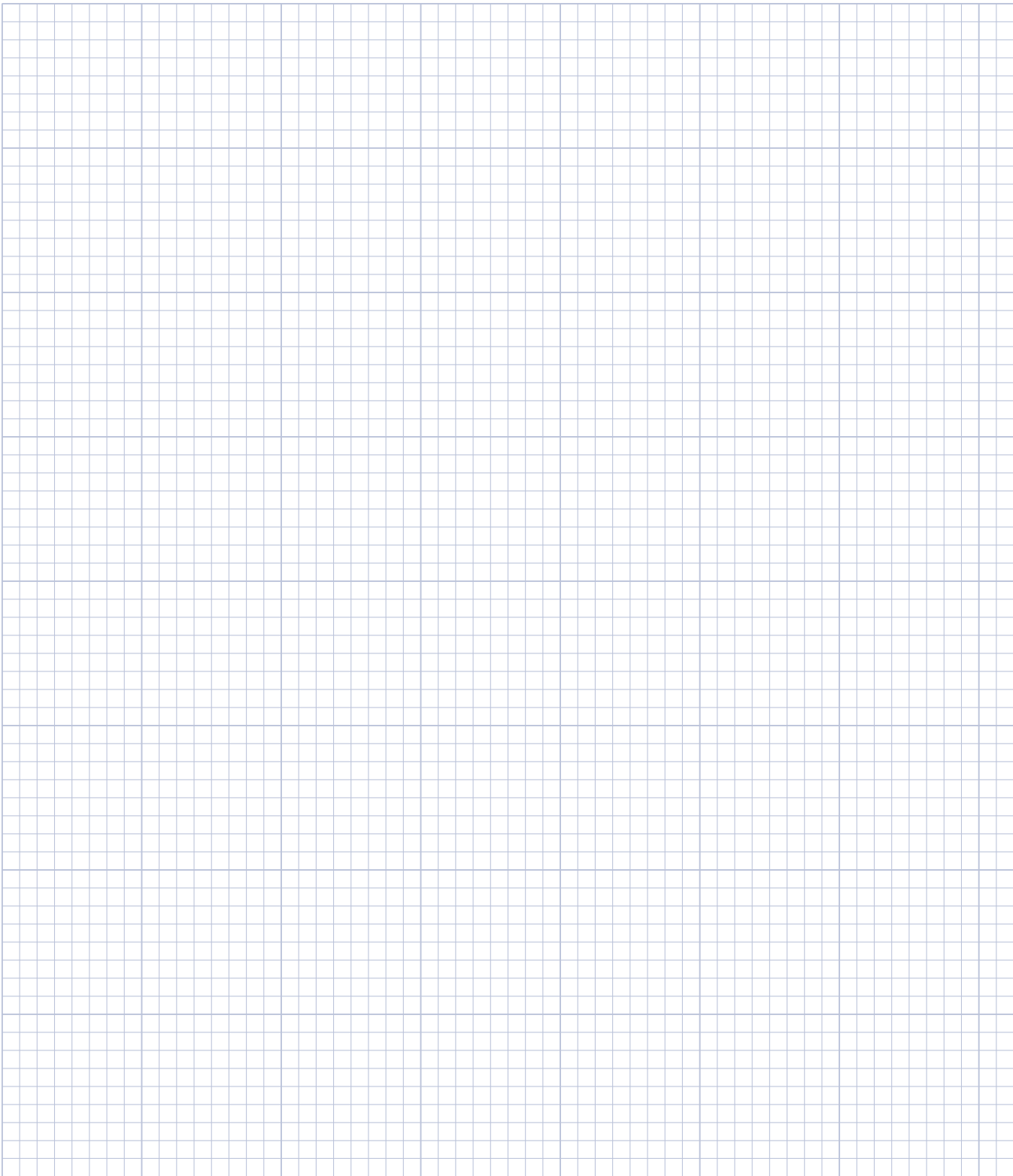

KBM 25 Frameless Motors

K B M 2 5

The KBM(S)-25 series is designed to operate over a broad speed range with high acceleration. Designed for maximum torque density with minimal cogging by using a variable air gap, the KBM(S)-25 is an ideal choice to meet or exceed your compact frameless motor application needs.

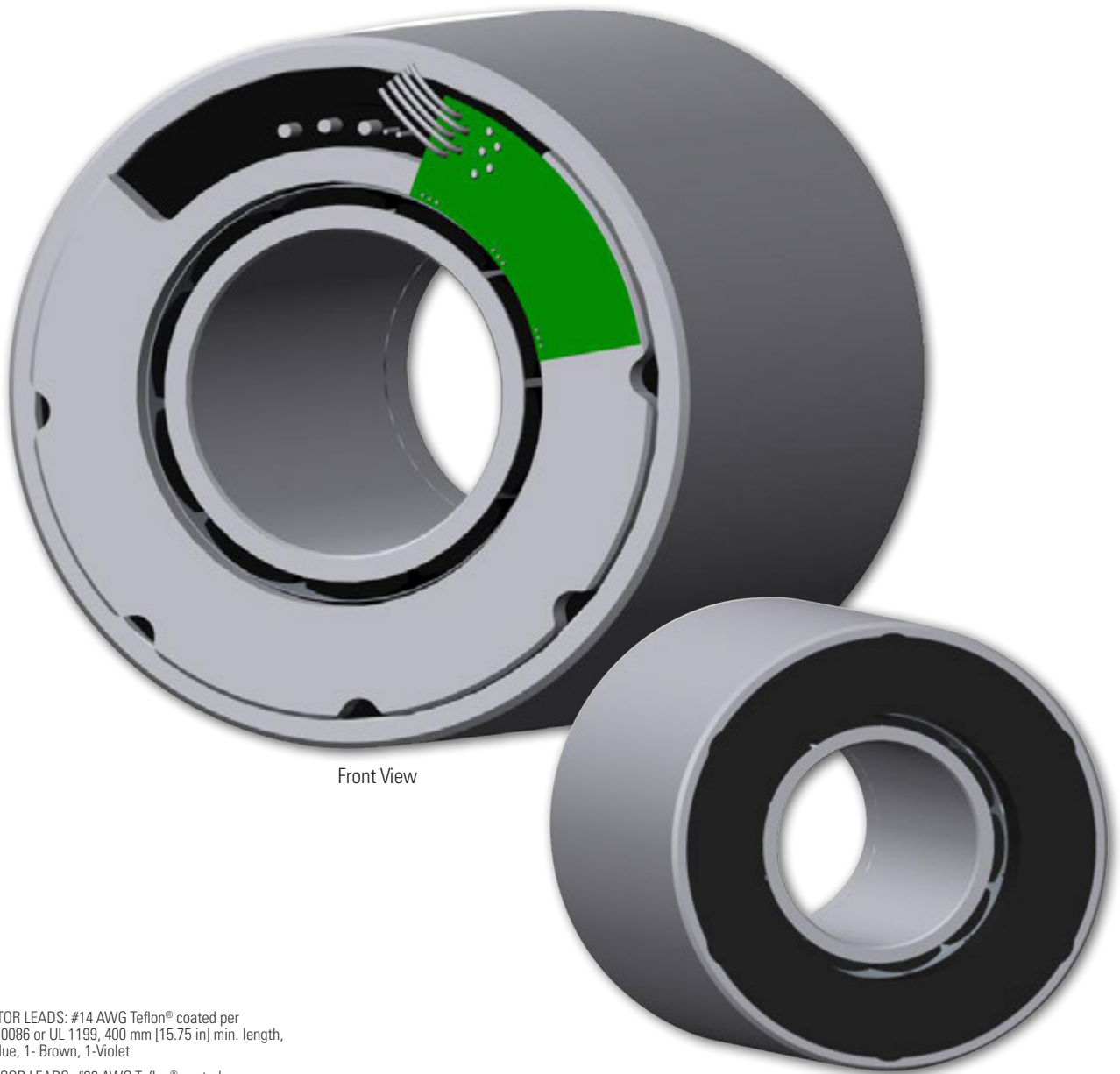

Front View

Rear View

MOTOR LEADS: #14 AWG Teflon® coated per UL 10086 or UL 1199, 400 mm [15.75 in] min. length, 1- Blue, 1- Brown, 1-Violet

SENSOR LEADS: #26 AWG Teflon® coated per MIL-W-22759/11, 400 mm [15.75 in] min. length, 1-Blue, 1-Orange, 1-Brown, 1-Green, 1-Yellow

THERMISTOR LEADS: #26 AWG Teflon® coated, UL Rated 600 Vdc, 150C Min, 400 mm [15.75"] min. length, 1-Blue, 1-Black

KBM 25 Outline Drawings

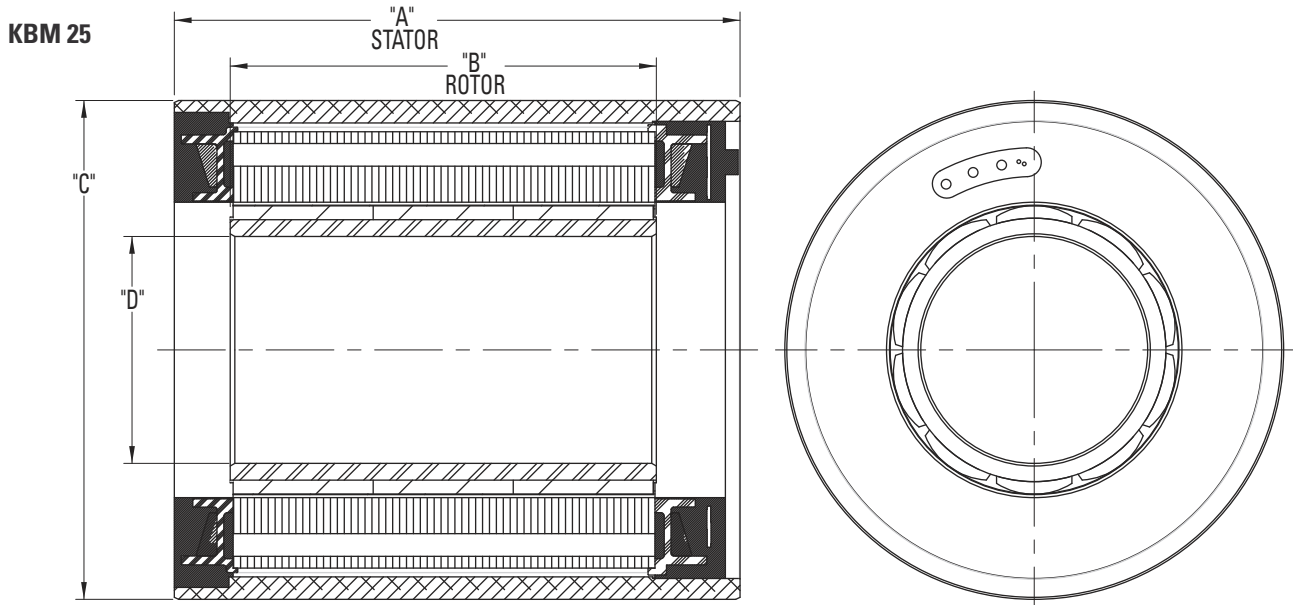

Model Number	"A" mm[inch]	"B" mm[inch]	Ø "C" mm[inch]	Ø "D" mm[inch]
KBM-25X01	62.70 [2.469]	32.16 [1.266]	109.965 [4.3293]	50.012 [1.9689]
KBM-25X02	93.70 [3.689]	63.05 [2.482]		
KBM-25X03	124.70 [4.909]	93.93 [3.698]		
KBM-25X04	155.70 [6.130]	124.82 [4.914]		

All dimensions are nominal. For more detailed and interactive 3D models with 2D product views, visit www.kollmorgen.com/kbm

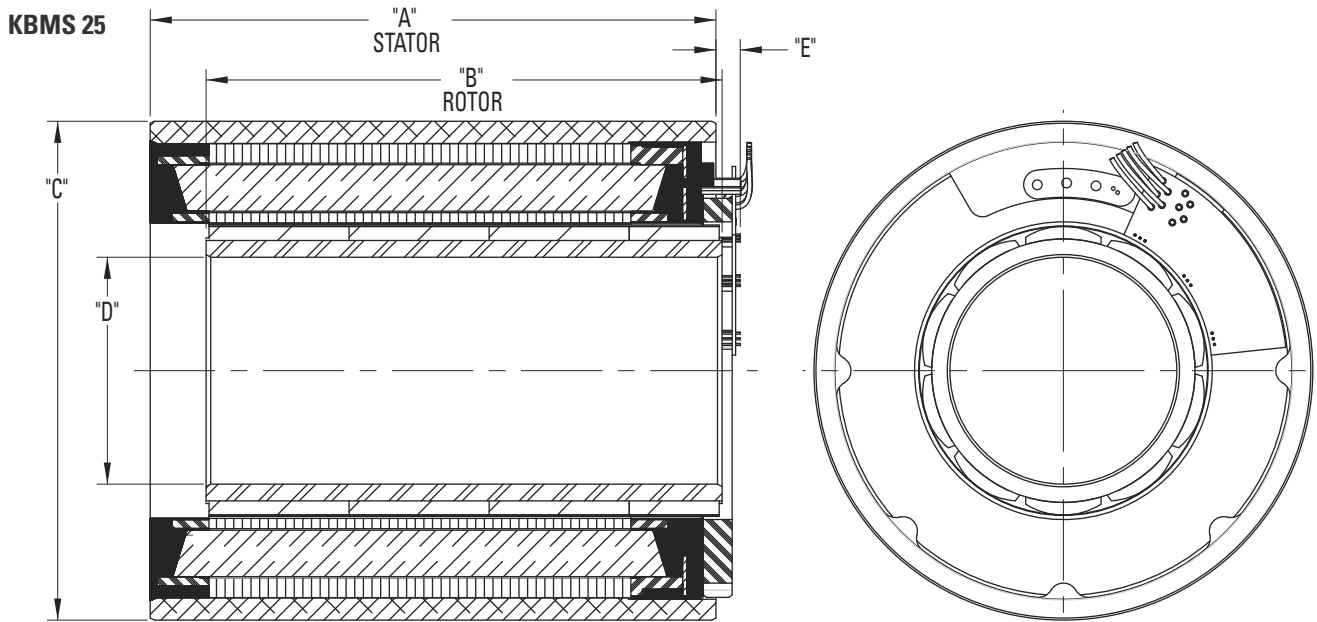

Model Number	"A" mm[inch]	"B" mm[inch]	Ø "C" mm[inch]	Ø "D" mm[inch]	"E" MAX mm[inch]
KBMS-25X01	62.70 [2.469]	51.97 [2.046]	109.965 [4.3293]	50.012 [1.9689]	5.75 [.226]
KBMS-25X02	93.70 [3.689]	82.86 [3.262]			
KBMS-25X03	124.70 [4.909]	113.74 [4.478]			
KBMS-25X04	155.70 [6.130]	144.63 [5.694]			

All dimensions are nominal. For more detailed and interactive 3D models with 2D product views, visit www.kollmorgen.com/kbm

KBM 25 Performance Data

KBM(S)-25XXX PERFORMANCE DATA & MOTOR PARAMETERS												
Motor Parameter	Symbol	Units	TOL	KBM(S)-25X01-X				KBM(S)-25X02-X				
				A	B	C	D	A	B	C	D	E
Continuous Stall Torque at 25°C Amb. (1)	Tc	Nm	NOM	4.90	4.96	4.85	4.75	8.70	8.75	8.75	8.62	8.85
		lb-ft		3.62	3.66	3.58	3.50	6.42	6.45	6.45	6.36	6.53
Continuous Current	Ic	Arms	NOM	3.10	5.34	6.45	7.95	3.33	5.18	6.50	8.00	10.20
Peak Stall Torque (25°C winding temp)	Tp	Nm	NOM	14.4	14.6	15.0	14.9	29.4	29.7	29.7	29.8	29.8
		lb-ft		10.6	10.8	11.1	11.0	21.7	21.9	21.9	22.0	22.0
Peak Current	Ip	Arms	NOM	10.9	19.3	27.6	34.3	13.9	22.0	27.8	35.1	43.3
Rated Continuous Output Power at 25°C Amb. (1)	P Rated	Watts		1110	730	1025	1100	1765	2545	2535	1790	1850
	HP Rated	HP		1.49	0.979	1.37	1.42	2.37	3.41	3.40	2.40	2.48
Speed at Rated Power	N Rated	RPM		3800	4900	4225	4000	2300	4000	5000	6000	6000
Torque Sensitivity (2)	Kt	Nm / Arms	+/-10%	1.66	0.950	0.766	0.613	2.67	1.73	1.38	1.11	0.890
		lb-ft / Arms		1.22	0.701	0.565	0.452	1.97	1.27	1.02	0.818	0.656
Back EMF Constant	Kb	Vrms / kRPM	+/- 10%	100	57.4	46.3	37.0	162	104	83.2	67.1	53.8
Motor Constant	Km	Nm/√watt	+/-10%	0.452	0.458	0.445	0.439	0.729	0.733	0.733	0.723	0.742
		lb-ft /√watt		0.334	0.338	0.328	0.324	0.538	0.541	0.541	0.533	0.547
Resistance (line to line)	Rm	Ohms	+/- 10%	8.98	2.87	1.97	1.30	8.96	3.70	2.35	1.57	0.960
Inductance	Lm	mH		37	12	7.9	5.2	45	19	12	7.8	5.0
Inertia (KBM)	Jm	Kg-m ²		2.66E-4				5.15E-4				
		lb-ft-s ²		1.96E-4				3.80E-4				
Weight (KBM)	Wt	Kg		1.79				3.27				
		lb		3.95				7.22				
Inertia (KBMS)	Jm	Kg-m ²		4.34E-4				6.78E-4				
		lb-ft-s ²		3.20E-4				5.00E-4				
Weight (KBMS)	Wt	Kg		2.02				3.50				
		lb		4.45				7.72				
Max Static Friction	Tf	Nm		9.25E-2				0.163				
		lb-ft		6.82E-2				0.120				
Cogging Friction (peak-to-peak)	Tcog	Nm		7.61E-2				0.132				
		lb-ft		5.61E-2				9.70E-2				
Viscous Damping	Fi	Nm/ kRPM		3.09E-2				3.95E-2				
		lb-ft / kRPM		2.28E-2				2.91E-2				
Thermal Resistance (4)	TPR	°C / watt		0.680				0.560				
Number of Poles	P	-		10				10				
Recommended Kollmorgen AKD Drive				00607	00607	01206	01206	00607	00607	01207	01207	01207
Voltage Req'd at Rated Output	Vac Input	Vac		480	400	240	240	480	480	480	480	400
Peak Stall Torque (5) (Motor with Drive)	Tp Drive	Nm	+/-10%	14.4	13.3	15.0	14.6	29.4	25.5	29.7	26.0	22.6
		lb-ft		10.6	9.81	11.1	10.8	21.7	18.8	21.9	19.2	16.7
Cont. Stall Torque (4) (Motor with Drive)	Tc Drive	Nm	+/-10%	4.90	4.96	4.85	4.75	8.70	8.75	8.75	8.62	8.85
		lb-ft		3.62	3.66	3.58	3.50	6.42	6.45	6.45	6.36	6.53

- Notes
- 1) Winding temperature = 155°C at continuous stall, at rated output, and for performance curve
 - 2) To calculate no-load Kt and Kb at 25°C, multiply by 1.064.
 - 3) TPR assumes motor is housed and mounted to a 12" x 12" x 1/2" heat sink or equivalent.
 - 4) Peak & Continuous Torques may be limited by drive current, see www.kollmorgen.com for complete drive ratings.

KBM(S)-25XXX PERFORMANCE DATA & MOTOR PARAMETERS												
Motor Parameter	Symbol	Units	TOL	KBM(S)-25X03-X				KBM(S)-25X04-X				
				A	B	C	D	A	B	C	D	E
Continuous Stall Torque at 25°C Amb. (1)	Tc	Nm	NOM	11.9	11.9	11.9	11.9	14.8	14.9	15.0	14.9	14.6
		lb-ft		8.75	8.75	8.75	8.80	10.9	11.0	11.1	11.0	10.8
Continuous Current	Ic	Arms	NOM	5.30	7.27	8.20	10.2	5.50	6.25	8.70	10.7	13.8
Peak Stall Torque (25°C winding temp)	Tp	Nm	NOM	42.2	42.3	42.4	42.6	54.4	53.8	54.4	54.8	53.8
		lb-ft		31.1	31.2	31.3	31.4	40.1	39.7	40.1	40.4	39.7
Peak Current	Ip	Arms	NOM	23.9	33.0	37.0	47.0	25.0	27.5	38.5	48.5	62.5
Rated Continuous Output Power at 25°C Amb. (1)	P Rated	Watts		2700	2890	2585	2605	2865	3090	3255	1990	1940
	HP Rated	HP		3.62	3.87	3.47	3.49	3.84	4.14	4.36	2.67	2.60
Speed at Rated Power	N Rated	RPM		2900	4150	4725	2700	2400	2700	3850	4700	4700
Torque Sensitivity (2)	Kt	Nm / Arms	+/-10%	2.29	1.66	1.49	1.19	2.76	2.46	1.79	1.44	1.08
		lb-ft / Arms		1.69	1.22	1.10	0.881	2.03	1.81	1.32	1.06	0.799
Back EMF Constant	Kb	Vrms / kRPM	+/- 10%	139	100	90.1	72.2	167	149	108	86.8	65.5
Motor Constant	Km	Nm/√watt	+/-10%	0.939	0.936	0.944	0.947	1.11	1.12	1.13	1.13	1.10
		lb-ft/√watt		0.693	0.690	0.696	0.698	0.822	0.827	0.834	0.832	0.809
Resistance (line to line)	Rm	Ohms	+/- 10%	3.97	2.10	1.66	1.06	4.08	3.20	1.66	1.08	0.650
Inductance	Lm	mH		21	11	9.1	5.7	23	18	10	6.2	3.5
Inertia (KBM)	Jm	Kg-m ²		7.66E-4				1.02E-3				
		lb-ft-s ²		5.65E-4				7.50E-4				
Weight (KBM)	Wt	Kg		4.72				6.17				
		lb		10.4				13.6				
Inertia (KBMS)	Jm	Kg-m ²		9.31E-4				1.18E-3				
		lb-ft-s ²		6.87E-4				8.72E-4				
Weight (KBMS)	Wt	Kg		4.90				6.35				
		lb		10.8				14.0				
Max Static Friction	Tf	Nm		0.226				0.289				
		lb-ft		0.167				0.213				
Cogging Friction (peak-to-peak)	Tcog	Nm		0.183				0.230				
		lb-ft		0.135				0.170				
Viscous Damping	Fi	Nm/ kRPM		5.19E-2				5.74E-2				
		lb-ft/ kRPM		3.83E-2				4.23E-2				
Thermal Resistance (3)	TPR	°C / watt		0.500				0.450				
Number of Poles	P	-		10				10				
Recommended Kollmorgen AKD Drive				00607	01207	01207	01207	00607	01207	01207	01207	02407
Voltage Req'd at Rated Output	Vac Input	Vac		480	480	480	400	480	480	480	480	400
Peak Stall Torque (4) (Motor with Drive)	Tp Drive	Nm	+/-10%	34.0	39.3	36.1	31.0	41.9	53.8	44.4	37.8	42.7
		lb-ft		25.1	29.0	26.6	22.9	30.9	39.7	32.7	27.9	31.5
Cont. Stall Torque (4) (Motor with Drive)	Tc Drive	Nm	+/-10%	11.9	11.9	11.9	11.9	14.8	14.9	15.0	14.9	14.6
		lb-ft		8.75	8.75	8.75	8.80	10.9	11.0	11.1	11.0	10.8

- Notes
- 1) Winding temperature = 155°C at continuous stall, at rated output, and for performance curve
 - 2) To calculate no-load Kt and Kb at 25°C, multiply by 1.064.
 - 3) TPR assumes motor is housed and mounted to a 12" x 12" x 1/2" heat sink or equivalent.
 - 4) Peak & Continuous Torques may be limited by drive current, see www.kollmorgen.com for complete drive ratings.

KBM 25 Performance Curves

Continuous duty capability for 130°C rise in a 25°C ambient using recommended AKD servo drive and sinusoidal commutation.

**KBM(S)-25X01
ContinuousTorque**

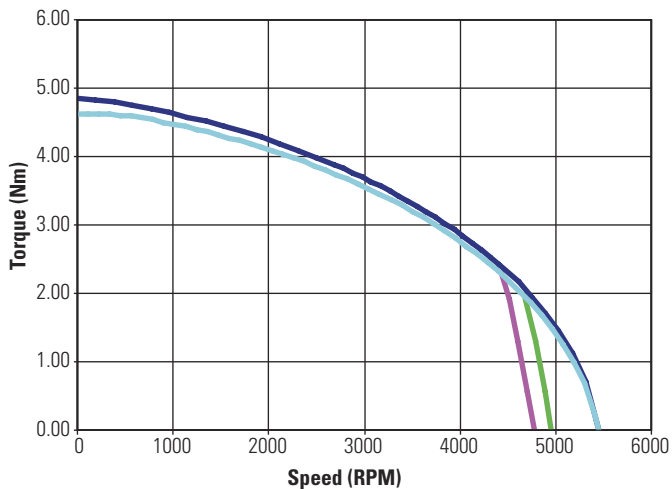

- A Winding-480 Vac
- B Winding-400 Vac
- C Winding-240 Vac
- D Winding-240 Vac

**KBM(S)-25X02
ContinuousTorque**

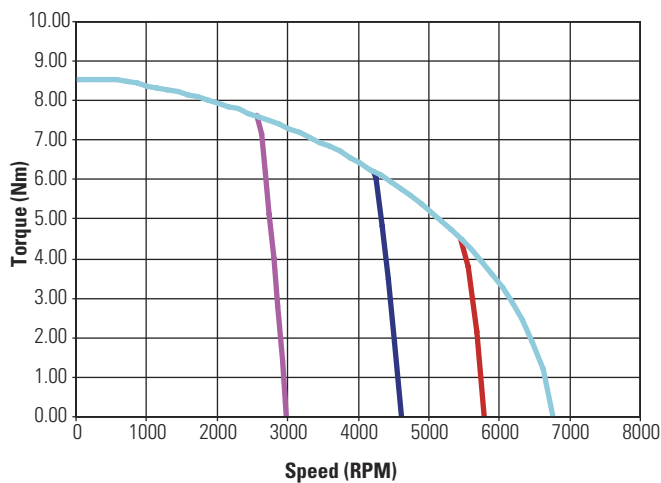

- A Winding-480 Vac
- B Winding-480 Vac
- C Winding-480 Vac
- D Winding-480 Vac
- E Winding-400 Vac

**KBM(S)-25X03
ContinuousTorque**

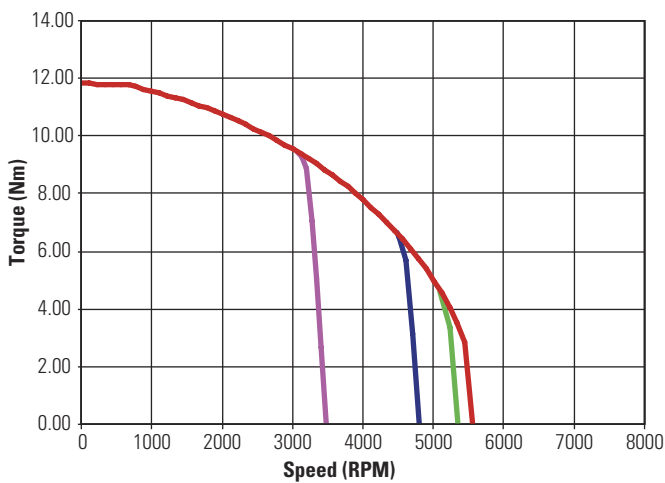

- A Winding-480 Vac
- B Winding-480 Vac
- C Winding-480 Vac
- D Winding-400 Vac

**KBM(S)-25X04
ContinuousTorque**

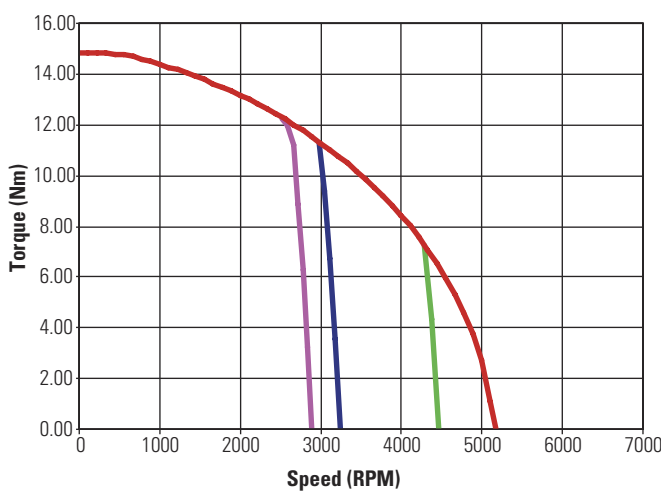

- A Winding-480 Vac
- B Winding-480 Vac
- C Winding-480 Vac
- D Winding-480 Vac
- E Winding-400 Vac

Low Voltage optimized windings available.

Notes

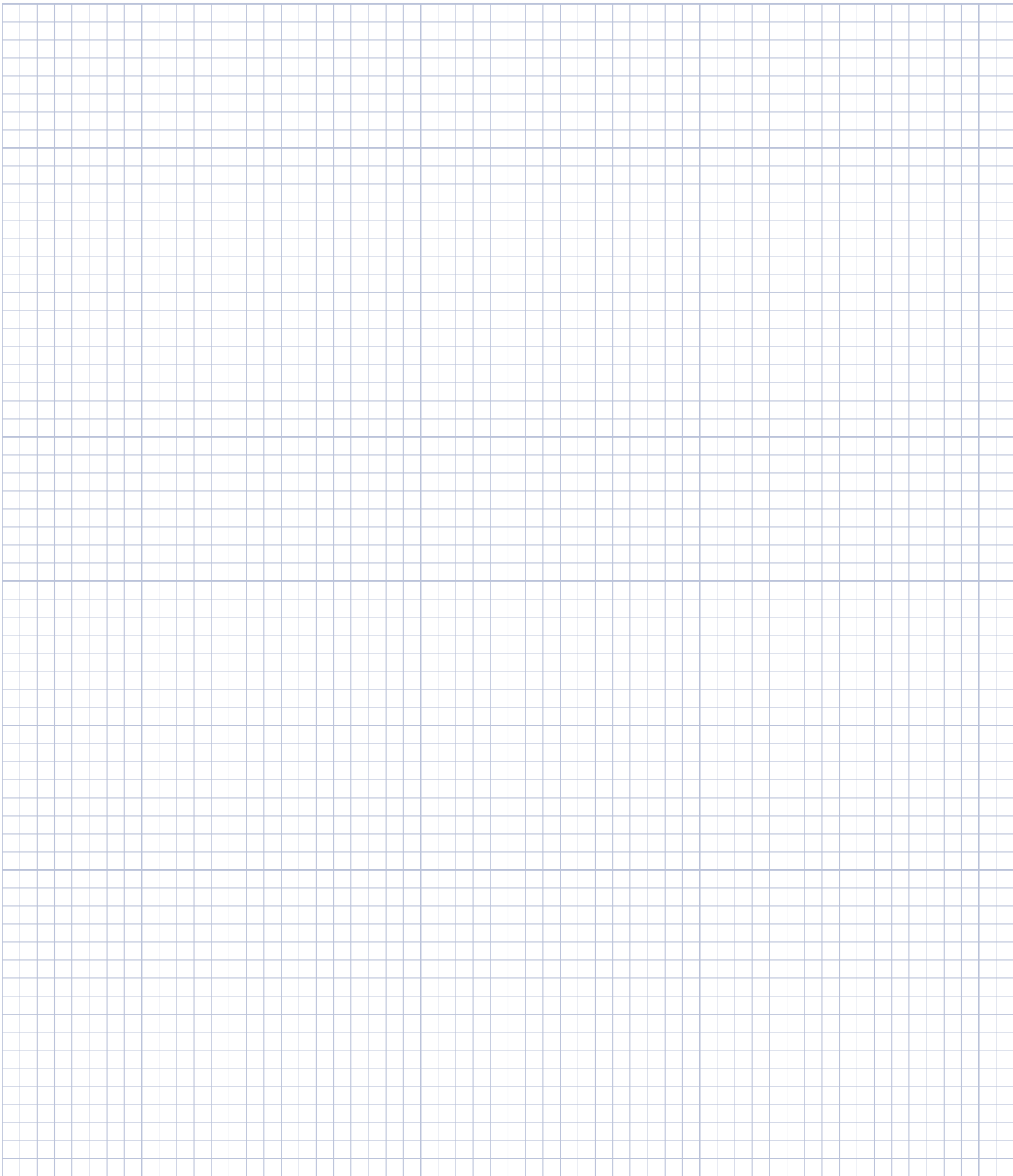

KBM 35 Frameless Motors

The KBM(S)-35 series is designed to operate over a broad speed range with high acceleration. Designed for maximum torque density with minimal cogging by using a variable air gap, the KBM(S)-35 is an ideal choice to meet or exceed your compact frameless motor application needs.

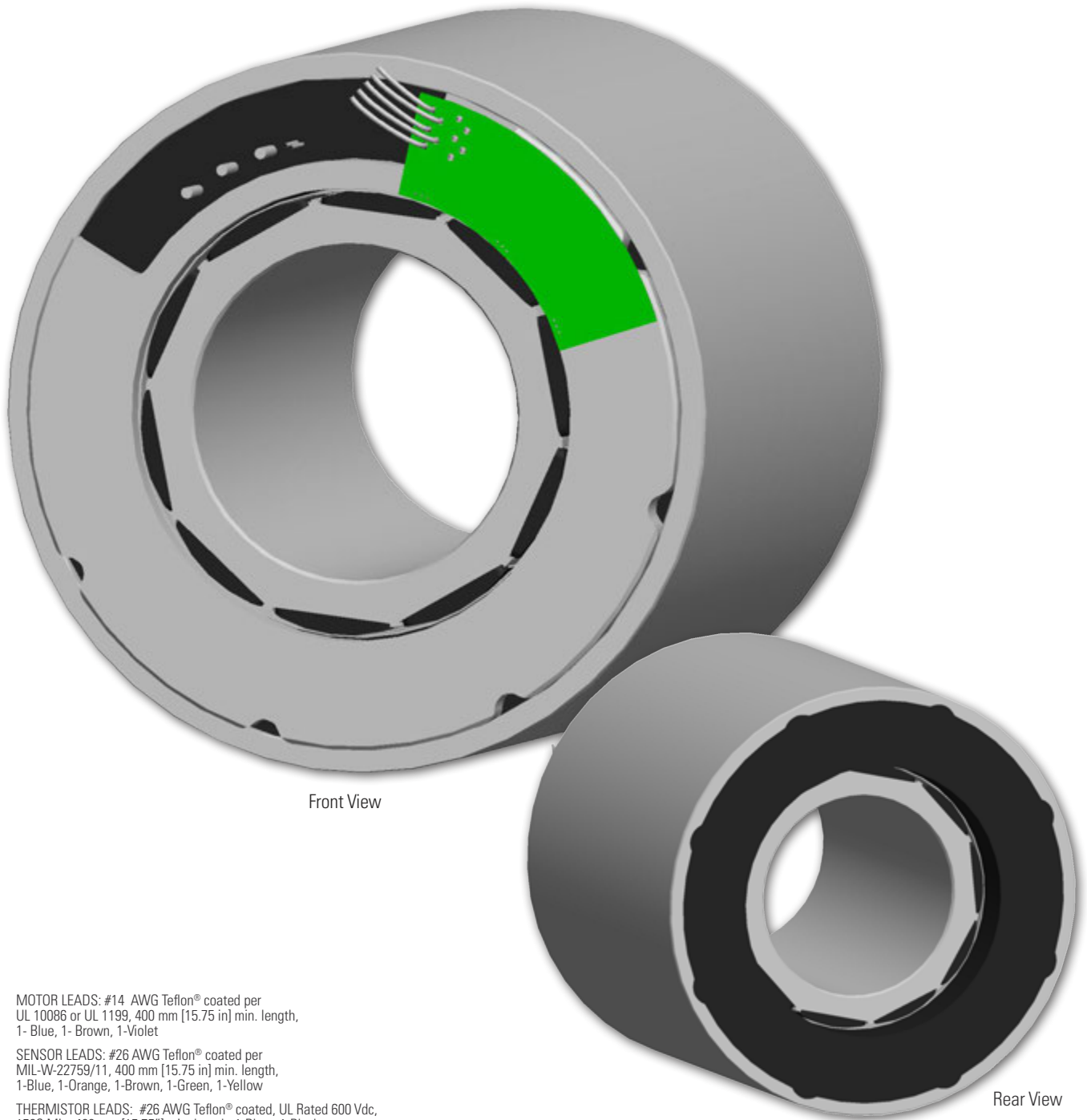

MOTOR LEADS: #14 AWG Teflon® coated per UL 10086 or UL 1199, 400 mm [15.75 in] min. length, 1-Blue, 1-Brown, 1-Violet

SENSOR LEADS: #26 AWG Teflon® coated per MIL-W-22759/11, 400 mm [15.75 in] min. length, 1-Blue, 1-Orange, 1-Brown, 1-Green, 1-Yellow

THERMISTOR LEADS: #26 AWG Teflon® coated, UL Rated 600 Vdc, 150C Min, 400 mm [15.75"] min. length, 1-Blue, 1-Black

KBM 35 Outline Drawings

KBM 35

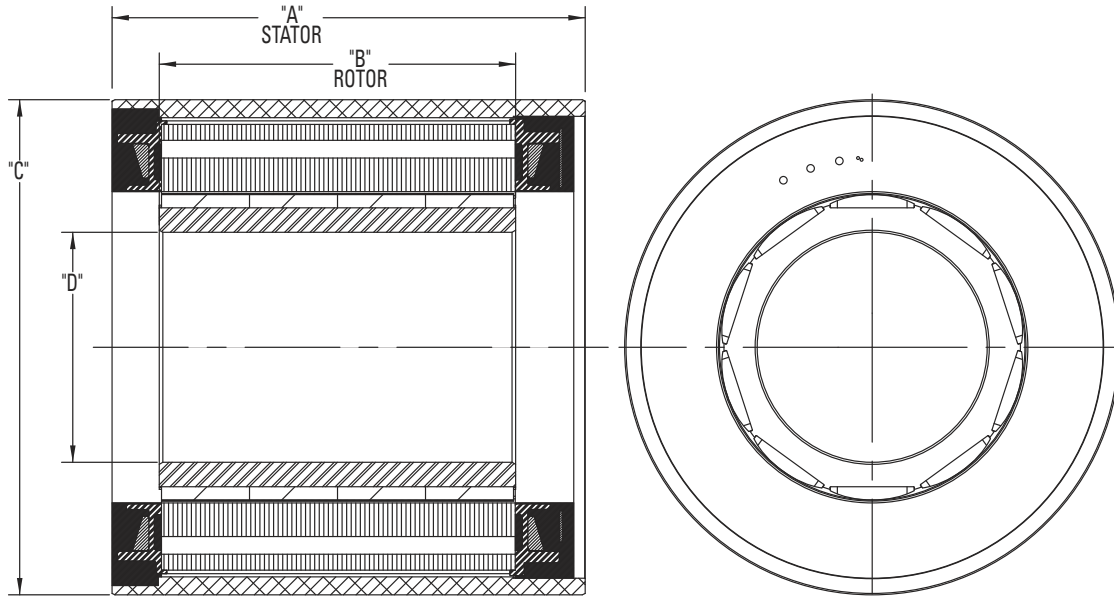

Model Number	"A" mm[inch]	"B" mm[inch]	Ø "C" mm[inch]	Ø "D" mm[inch]
KBM-35X01	83.74 [3.297]	51.00 [2.008]	139.956 [5.5101]	65.012 [2.5595]
KBM-35X02	108.74 [4.281]	75.87 [2.987]		
KBM-35X03	133.74 [5.265]	100.74 [3.966]		
KBM-35X04	158.74 [6.250]	125.60 [4.945]		

All dimensions are nominal. For more detailed and interactive 3D models with 2D product views, visit www.kollmorgen.com/kbm

KBMS 35

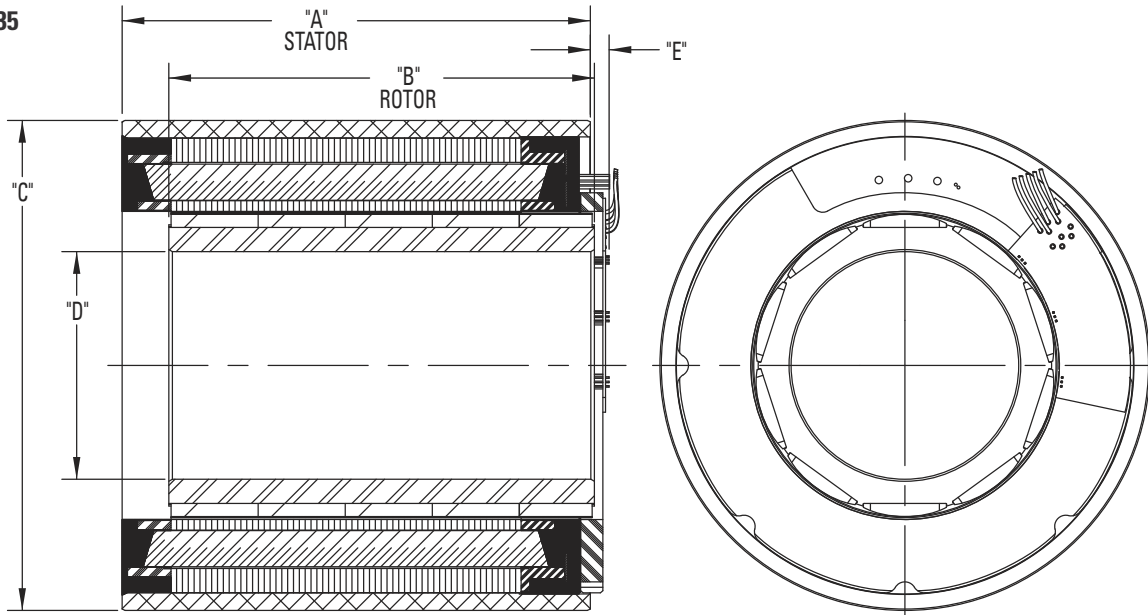

Model Number	"A" mm[inch]	"B" mm[inch]	Ø "C" mm[inch]	Ø "D" mm[inch]	"E" MAX mm[inch]
KBMS-35X01	83.74 [3.297]	71.83 [2.828]	139.956 [5.5101]	65.012 [2.5595]	5.75 [.226]
KBMS-35X02	108.74 [4.281]	96.70 [3.807]			
KBMS-35X03	133.74 [5.265]	121.56 [4.786]			
KBMS-35X04	158.74 [6.250]	146.43 [5.765]			

All dimensions are nominal. For more detailed and interactive 3D models with 2D product views, visit www.kollmorgen.com/kbm

KBM 35 Performance Data

KBM(S)-35XXX PERFORMANCE DATA & MOTOR PARAMETERS													
Motor Parameter	Symbol	Units	TOL	KBM(S)-35X01-X					KBM(S)-35X02-X				
				A	B	C	D	E	A	B	C	D	E
Continuous Stall Torque at 25°C Amb. (1)	Tc	Nm	NOM	12.6	12.7	12.4	12.7	12.2	17.3	17.6	17.5	17.5	17.1
		lb-ft		9.26	9.34	9.15	9.34	9.00	12.8	13.0	12.9	12.9	12.6
Continuous Current	Ic	Arms	NOM	5.41	6.10	8.32	10.6	12.9	4.97	6.30	8.70	10.9	12.1
Peak Stall Torque (25°C winding temp)	Tp	Nm	NOM	40.9	40.8	41.1	41.2	41.1	58.8	58.8	59.2	59.4	59.4
		lb-ft		30.1	30.1	30.3	30.4	30.3	43.4	43.4	43.7	43.8	43.8
Peak Current	Ip	Arms	NOM	21.9	24.5	34.7	43.5	55.4	22.5	28.0	39.2	49.5	55.4
Rated Continuous Output Power at 25°C Amb. (1)	P Rated	Watts		2970	3100	3885	3750	3200	2750	3415	4395	4750	4610
	HP Rated	HP		3.98	4.16	5.21	5.03	4.29	3.69	4.58	5.89	6.37	6.18
Speed at Rated Power	N Rated	RPM		2700	2900	4200	5800	6125	1750	2200	3200	4300	3765
Torque Sensitivity (2)	Kt	Nm /Arms	+/-10%	2.37	2.11	1.53	1.23	0.956	3.55	2.87	2.05	1.64	1.46
		lb-ft /Arms		1.75	1.55	1.13	0.904	0.705	2.62	2.12	1.51	1.21	1.08
Back EMF Constant	Kb	Vrms / kRPM	+/- 10%	144	127	92.7	74.1	57.8	215	174	124	98.9	88.4
Motor Constant	Km	Nm/√watt	+/-10%	0.954	0.947	0.946	0.963	0.908	1.24	1.27	1.25	1.25	1.23
		lb-ft /√watt		0.704	0.699	0.698	0.710	0.670	0.912	0.934	0.921	0.923	0.908
Resistance (line to line)	Rm	Ohms	+/- 10%	4.13	3.30	1.75	1.08	0.740	5.50	3.43	1.80	1.14	0.940
Inductance	Lm	mH		32	25	13	8.5	5.4	44	28	15	9.3	7.4
Inertia (KBM)	Jm	Kg-m ²		1.52E-3					2.28E-3				
		lb-ft-s ²		1.12E-3					1.68E-3				
Weight (KBM)	Wt	Kg		4.68					6.76				
		lb		10.3					14.9				
Inertia (KBMS)	Jm	Kg-m ²		2.17E-3					2.94E-3				
		lb-ft-s ²		1.60E-3					2.17E-3				
Weight (KBMS)	Wt	Kg		5.17					7.21				
		lb		11.4					15.9				
Max Static Friction	Tf	Nm		0.247					0.346				
		lb-ft		0.182					0.255				
Cogging Friction (peak-to-peak)	Tcog	Nm		0.197					0.271				
		lb-ft		0.145					0.200				
Viscous Damping	Fi	Nm/ kRPM		3.76E-2					5.99E-2				
		lb-ft /kRPM		2.77E-2					4.42E-2				
Thermal Resistance (3)	TPR	°C / watt		0.460					0.410				
Number of Poles	P	-		10					10				
Recommended Kollmorgen AKD Drive				00607	01207	01207	01207	02407	00607	01207	01207	01207	02407
Voltage Req'd at Rated Output	Vac Input	Vac		480	480	480	480	400	480	480	480	480	400
Peak Stall Torque (4) (Motor with Drive)	Tp Drive	Nm	+/-10%	37.5	40.8	35.0	28.8	35.0	49.1	58.8	47.7	39.2	52.9
		lb-ft		27.7	30.1	25.8	21.2	25.8	36.2	43.4	35.2	28.9	39.0
Cont. Stall Torque (4) (Motor with Drive)	Tc Drive	Nm	+/-10%	12.6	12.7	12.4	12.7	12.2	17.3	17.6	17.5	17.5	17.1
		lb-ft		9.26	9.34	9.15	9.34	9.00	12.8	13.0	12.9	12.9	12.6

- Notes
- 1) Winding temperature = 155°C at continuous stall, at rated output, and for performance curves.
 - 2) To calculate no-load Kt and Kb at 25°C, multiply by 1.064.
 - 3) TPR assumes motor is housed and mounted to a 18" x 18" x 1/2" heat sink or equivalent.
 - 4) Peak & Continuous Torques may be limited by drive current, see www.kollmorgen.com for complete drive ratings.

KBM(S)-35XXX PERFORMANCE DATA & MOTOR PARAMETERS											
Motor Parameter	Symbol	Units	TOL	KBM(S)-35X03-X				KBM(S)-35X04-X			
				A	B	C	D	A	B	C	D
Continuous Stall Torque at 25°C Amb. (1)	Tc	Nm	NOM	21.8	21.7	20.7	20.0	25.6	25.9	25.3	24.7
		lb-ft		16.1	16.0	15.3	14.8	18.9	19.1	18.7	18.2
Continuous Current	Ic	Arms	NOM	10.2	14.0	20.2	21.5	10.9	13.3	14.7	19.2
Peak Stall Torque (25°C winding temp)	Tp	Nm	NOM	76.1	76.6	75.2	75.7	92.3	93.0	93.0	91.5
		lb-ft		56.1	56.5	55.5	55.8	68.1	68.6	68.6	67.5
Peak Current	Ip	Arms	NOM	46.1	64.0	93.1	104	49.0	61.0	68.0	89.0
Rated Continuous Output Power at 25°C Amb. (1)	P Rated	Watts		5025	5160	2985	4735	5400	5750	4870	4500
	HP Rated	HP		6.74	6.92	4.00	6.35	7.24	7.71	6.53	6.03
Speed at Rated Power	N Rated	RPM		3100	4800	5000	3400	2800	3400	4150	4250
Torque Sensitivity (2)	Kt	Nm /Arms	+/-10%	2.19	1.59	1.05	.956	2.44	2.01	1.76	1.32
		lb-ft /Arms		1.62	1.17	0.776	0.705	1.80	1.48	1.30	0.975
Back EMF Constant	Kb	Vrms / kRPM	+/- 10%	133	96.2	63.7	57.8	147	121	107	79.9
Motor Constant	Km	Nm/√watt	+/-10%	1.51	1.50	1.43	1.38	1.71	1.73	1.68	1.65
		lb-ft/√watt		1.11	1.11	1.06	1.02	1.26	1.28	1.24	1.21
Resistance (line to line)	Rm	Ohms	+/- 10%	1.41	0.750	0.360	0.320	1.35	0.900	0.730	0.430
Inductance	Lm	mH		12	6.2	2.8	2.3	11	7.6	6.1	3.4
Inertia (KBM)	Jm	Kg-m ²		3.04E-3				3.81E-3			
		lb-ft-s ²		2.24E-3				2.81E-3			
Weight (KBM)	Wt	Kg		8.80				10.9			
		lb		19.4				24.0			
Inertia (KBMS)	Jm	Kg-m ²		3.70E-3				4.46E-3			
		lb-ft-s ²		2.73E-3				3.29E-3			
Weight (KBMS)	Wt	Kg		9.34				11.3			
		lb		20.6				25.0			
Max Static Friction	Tf	Nm		0.450				0.598			
		lb-ft		0.332				0.441			
Cogging Friction (peak-to-peak)	Tcog	Nm		0.338				0.399			
		lb-ft		0.249				0.294			
Viscous Damping	Fi	Nm/ kRPM		7.51E-2				9.40E-2			
		lb-ft /kRPM		5.54E-2				6.93E-2			
Thermal Resistance (3)	TPR	°C / watt		0.380				0.350			
Number of Poles	P	-		10				10			
Recommended Kollmorgen AKD Drive				01207	02407	02407	02406	01207	02407	02407	02407
Voltage Req'd at Rated Output	Vac Input	Vac		480	480	400	240	480	480	480	400
Peak Stall Torque (4) (Motor with Drive)	Tp Drive	Nm	+/-10%	52.2	39.2	40.5	37.7	58.0	73.9	66.1	50.8
		lb-ft		38.5	28.9	29.9	27.8	42.8	54.5	48.7	37.5
Cont. Stall Torque (4) (Motor with Drive)	Tc Drive	Nm	+/-10%	21.8	21.7	20.7	20.0	25.6	25.9	25.3	24.7
		lb-ft		16.1	16.0	15.3	14.8	18.8	19.1	18.7	18.2

- Notes 1) Winding temperature = 155°C at continuous stall, at rated output, and for performance curves.
2) To calculate no-load Kt and Kb at 25°C, multiply by 1.064.
3) TPR assumes motor is housed and mounted to a 18" x 18" x 1/2" heat sink or equivalent.
4) Peak & Continuous Torques may be limited by drive current, see www.kollmorgen.com for complete drive ratings.

KBM 35 Performance Curves

Continuous duty capability for 130°C rise in a 25°C ambient using recommended AKD servo drive and sinusoidal commutation.

**KBM(S)-35X01
Continuous Torque**

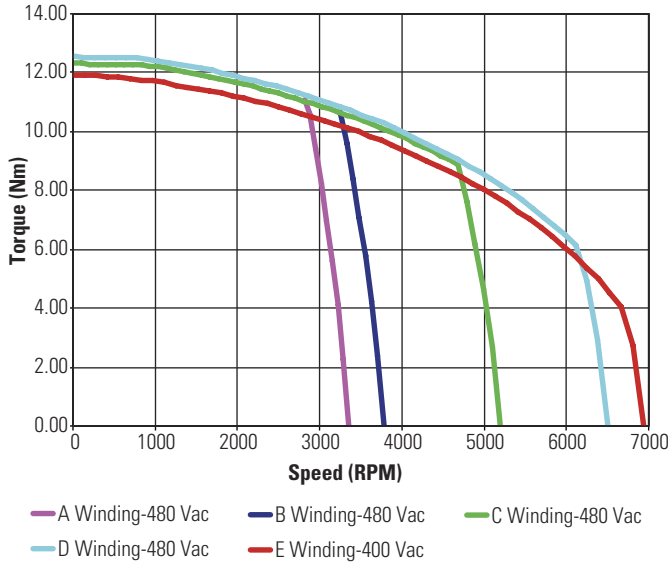

**KBM(S)-35X02
Continuous Torque**

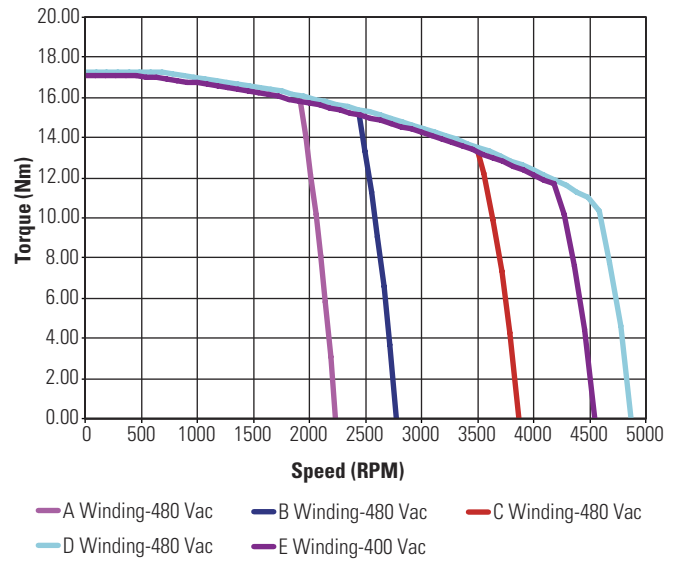

**KBM(S)-35X03
Continuous Torque**

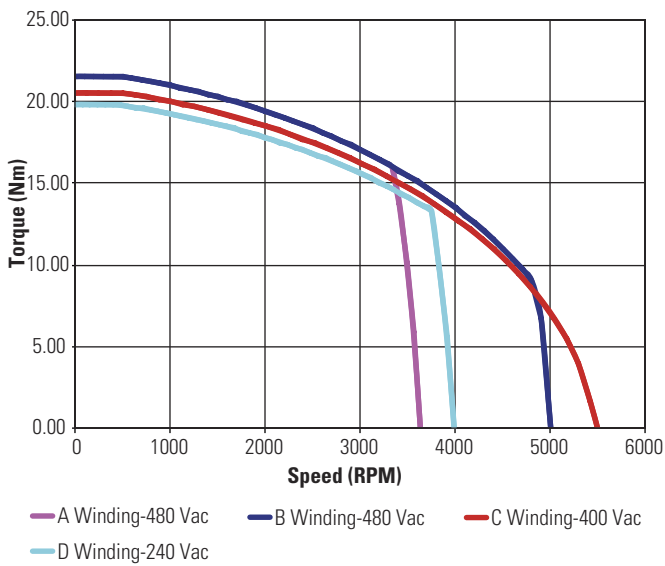

**KBM(S)-35X04
Continuous Torque**

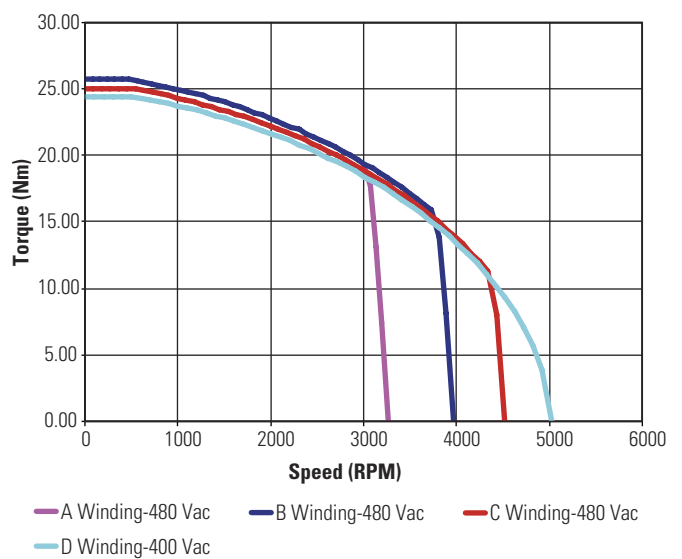

Low Voltage optimized windings available.

Notes

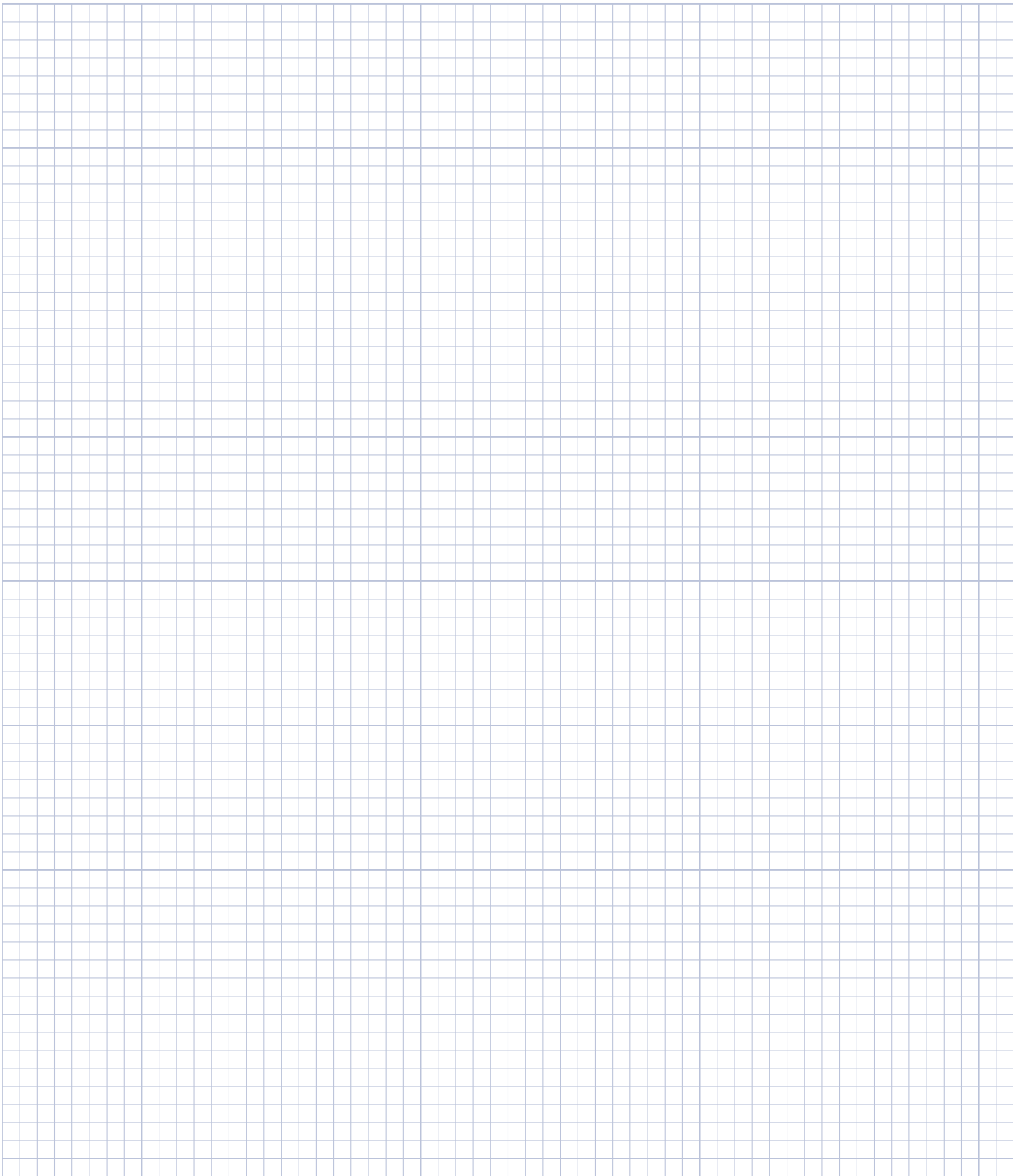

KBM 43 Frameless Motors

K B M 4 3

The KBM(S)-43 series provides a classic torque motor footprint - large diameter with a short axial length. With a skewed stator, low cogging, and low harmonic distortion these motors produce extremely smooth rotation. In addition, the high pole count and excellent torque / volume ratio makes the KBM(S)-43 an ideal fit for direct drive applications requiring high torque at low to moderate speeds.

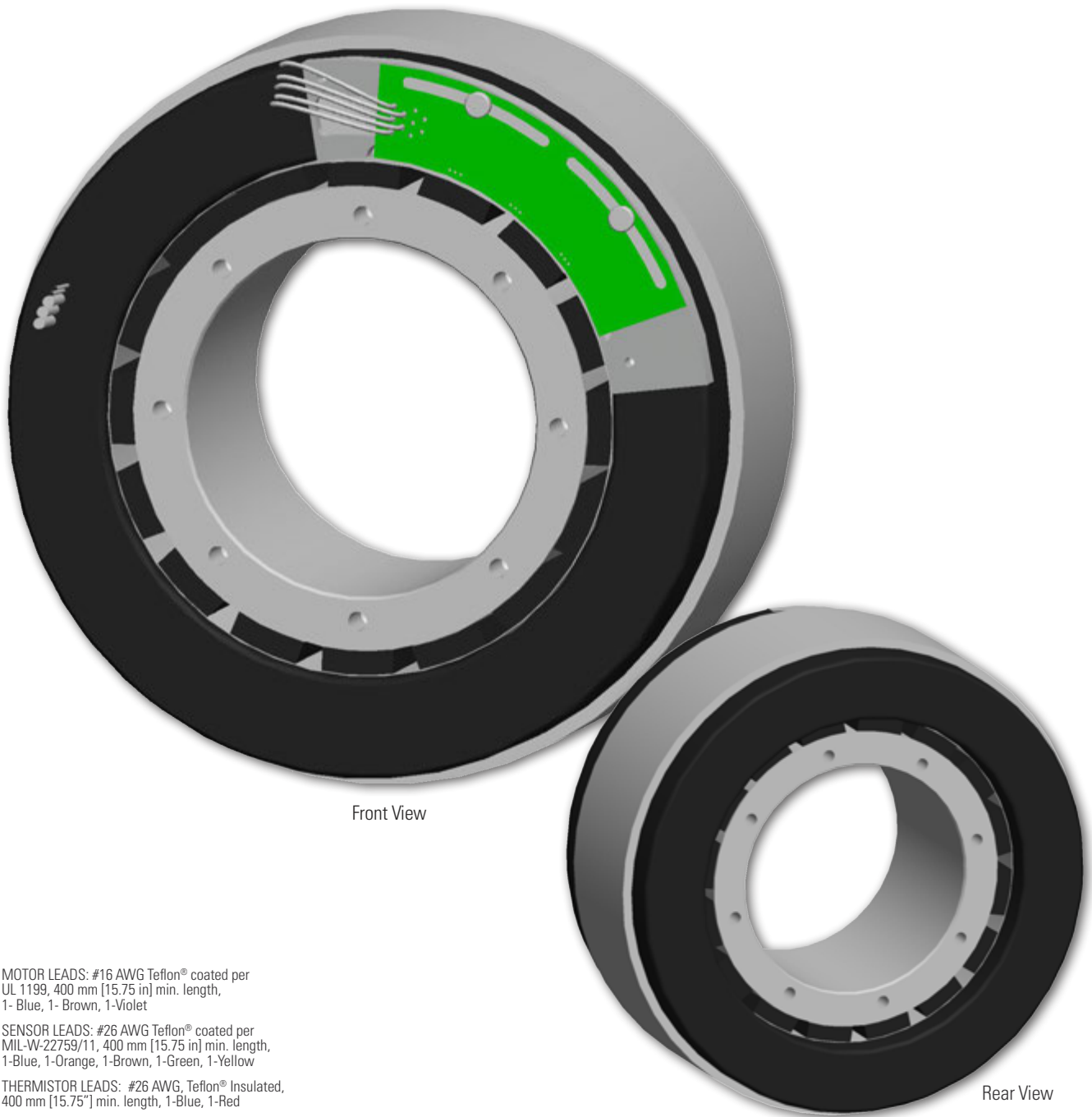

MOTOR LEADS: #16 AWG Teflon® coated per UL 1199, 400 mm [15.75 in] min. length, 1- Blue, 1- Brown, 1-Violet

SENSOR LEADS: #26 AWG Teflon® coated per MIL-W-22759/11, 400 mm [15.75 in] min. length, 1-Blue, 1-Orange, 1-Brown, 1-Green, 1-Yellow

THERMISTOR LEADS: #26 AWG, Teflon® Insulated, 400 mm [15.75"] min. length, 1-Blue, 1-Red

KBM 43 Outline Drawings

KBM 43

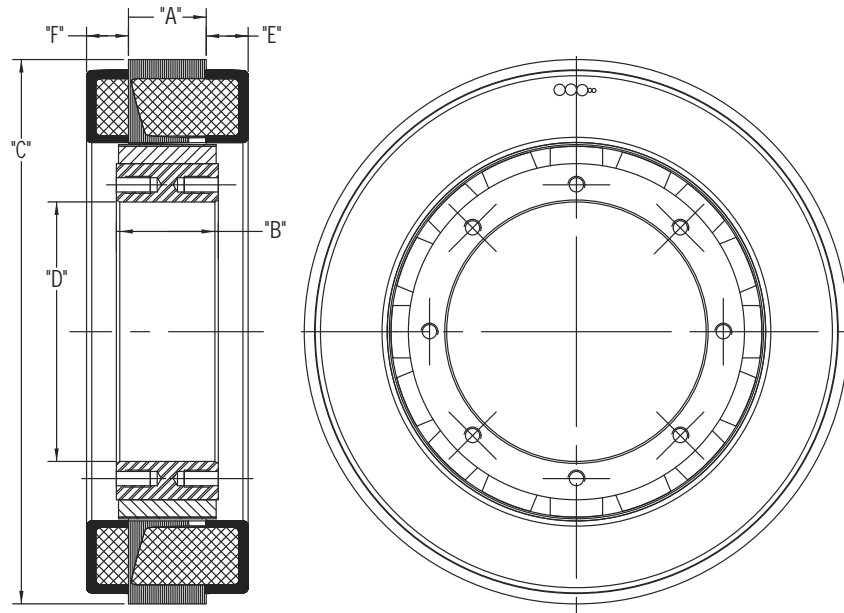

Model Number	"A" mm[inch]	"B" mm[inch]	∅ "C" mm[inch]	∅ "D" mm[inch]	"E" MAX mm[inch]	"F" MAX mm[inch]
KBM-43X01	11.43 [.450]	18.54 [.730]	159.78 [6.290]	76.28 [3.003]	12.32 [.485]	12.32 [.485]
KBM-43X02	22.86 [.900]	29.97 [1.180]				
KBM-43X03	45.72 [1.800]	52.83 [2.080]				
KBM-43X04	80.26 [3.160]	87.38 [3.440]				
KBM-43X05	108.97 [4.290]	116.08 [4.570]				

All dimensions are nominal. For more detailed and interactive 3D models with 2D product views, visit www.kollmorgen.com/kbm

KBMS 43

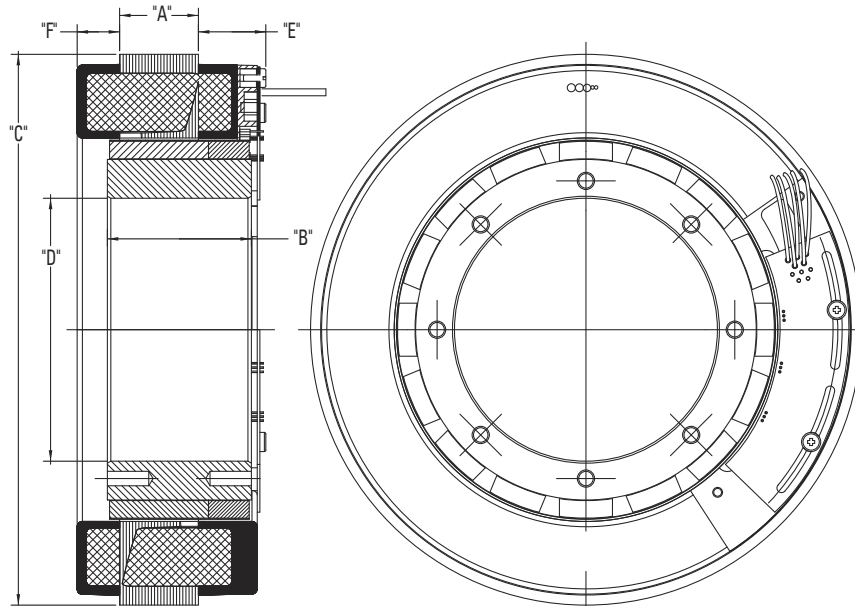

Model Number	"A" mm[inch]	"B" mm[inch]	∅ "C" mm[inch]	∅ "D" mm[inch]	"E" MAX mm[inch]	"F" MAX mm[inch]
KBMS-43X01	11.43 [.450]	30.35 [1.195]	159.78 [6.290]	76.28 [3.003]	20.32 [.800]	12.32 [.485]
KBMS-43X02	22.86 [.900]	41.78 [1.645]				
KBMS-43X03	45.72 [1.800]	64.64 [2.545]				
KBMS-43X04	80.26 [3.160]	99.19 [3.905]				
KBMS-43X05	108.97 [4.290]	127.89 [5.0325]				

All dimensions are nominal. For more detailed and interactive 3D models with 2D product views, visit www.kollmorgen.com/kbm

KBM 43 Performance Data

KBM(S)-43XXX PERFORMANCE DATA & MOTOR PARAMETERS														
Motor Parameter	Symbol	Units	TOL	KBM(S)-43X01-X			KBM(S)-43X02-X				KBM(S)-43X03-X			
				A	B	C	A	B	C	D	A	B	C	D
Continuous Stall Torque at 25°C Amb. (1)	Tc	Nm	NOM	6.11	6.24	6.11	11.6	11.6	11.9	11.9	21.0	20.7	20.9	20.9
		lb-ft		4.51	4.60	4.51	8.57	8.53	8.57	8.57	15.5	15.3	15.4	15.4
Continuous Current	Ic	Arms	NOM	5.10	8.60	18.4	5.10	18.3	6.10	10.2	4.78	13.8	5.73	19.2
Peak Stall Torque (25°C winding temp)	Tp	Nm	NOM	18.0	18.0	18.0	34.6	34.6	34.6	34.6	64.5	64.5	64.5	64.5
		lb-ft		13.3	13.3	13.3	25.5	25.5	25.5	25.5	47.6	47.6	47.6	47.6
Peak Current	Ip	Arms	NOM	18.0	32.2	64.6	18.0	64.6	22.8	36.2	18.0	51.2	22.8	72.5
Rated Continuous Output Power at 25°C Amb. (1)	P Rated	Watts		1230	1230	1230	2160	2160	2160	2160	2520	2875	2520	2520
	HP Rated	HP		1.65	1.65	1.65	2.90	2.90	2.90	2.90	3.38	3.85	3.38	3.38
Speed at Rated Power	N Rated	RPM		4750	4750	4750	3000	2650	3000	3000	1500	2275	1500	1500
Torque Sensitivity (2)	Kt	Nm / Arms	+/-10%	1.21	0.721	0.335	2.31	0.641	1.92	1.15	4.43	1.54	3.69	1.11
		lb-ft / Arms		0.890	0.531	0.247	1.70	0.473	1.42	0.851	3.27	1.14	2.73	0.818
Back EMF Constant	Kb	Vrms/kRPM	+/- 10%	72.8	43.6	20.3	139.3	38.7	116	69.8	268	93.3	223	67.0
Motor Constant	Km	Nm/√watt	+/-10%	0.579	0.596	0.58	1.00	1.00	1.00	1.00	1.65	1.63	1.69	1.65
		lb-ft / √watt		0.427	0.440	0.425	0.737	0.737	0.737	0.737	1.21	1.20	1.24	1.21
Resistance (line to line)	Rm	Ohms	+/- 10%	2.90	0.976	0.226	3.55	0.277	2.35	0.886	4.83	0.595	3.20	0.301
Inductance	Lm	mH		6.8	2.4	0.520	12	0.93	8.3	3.0	19	2.2	13.0	1.2
Inertia (KBM)	Jm	Kg-m ²		1.94E-3			2.85E-3				4.75E-3			
		lb-ft-s ²		1.43E-3			2.10E-3				3.50E-3			
Weight (KBM)	Wt	Kg		2.26			3.49				5.96			
		lb		4.98			7.70				13.1			
Inertia (KBMS)	Jm	Kg-m ²		2.85E-3			3.73E-3				5.69E-3			
		lb-ft-s ²		2.10E-3			2.75E-3				4.20E-3			
Weight (KBMS)	Wt	Kg		2.66			3.89				6.35			
		lb		5.86			8.57				14.0			
Max Static Friction	Tf	Nm		0.058			0.108				0.203			
		lb-ft		0.043			0.080				0.150			
Cogging Friction (peak-to-peak)	Tcog	Nm		0.027			0.054				0.102			
		lb-ft		0.020			0.040				0.075			
Viscous Damping	Fi	Nm/ kRPM		0.388			0.561				0.860			
		lb-ft / kRPM		0.286			0.414				1.17			
Thermal Resistance (3)	TPR	°C / watt		0.763			0.629				0.525			
Number of Poles	P	-		16			16				16			
Recommended Kollmorgen AKD Drive				00607	01206	02406	00607	02406	01207	01206	00607	02406	00607	02406
Voltage Req'd at Rated Output	Vac Input	Vac		400	240	120	480	120	400	240	480	240	400	120
Peak Stall Torque (4) (Motor with Drive)	Tp Drive	Nm	+/-10%	18.0	17.5	13.7	34.6	26.1	34.6	29.0	64.5	59.5	55.3	45.0
		lb-ft		13.3	12.9	10.1	25.5	19.3	25.5	21.4	47.6	43.9	40.8	33.2
Cont. Stall Torque (4) (Motor with Drive)	Tc Drive	Nm	+/-10%	6.11	6.24	6.11	11.6	11.6	11.9	11.9	21.0	20.7	20.9	20.9
		lb-ft		4.51	4.60	4.51	8.56	8.56	8.78	8.78	15.5	15.3	15.4	15.4

- Notes
- 1) Winding temperature = 155°C at continuous stall, at rated output, and for performance curves.
 - 2) To calculate no-load Kt and Kb at 25°C, multiply by 1.064.
 - 3) TPR assumes motor is housed and mounted to a 18" x 18" x 1/2" heat sink or equivalent.
 - 4) Peak & Continuous Torques may be limited by drive current, see www.kollmorgen.com for complete drive ratings.

KBM(S)-43XXX PERFORMANCE DATA & MOTOR PARAMETERS

Motor Parameter	Symbol	Units	TOL	KBM(S)-43X04-X			KBM(S)-43X05-X		
				A	B	C	A	B	C
Continuous Stall Torque at 25°C Amb. (1)	Tc	Nm	NOM	35.1	35.1	35.1	44.2	44.2	44.2
		lb-ft		25.9	25.9	25.9	32.6	32.6	32.6
Continuous Current	Ic	Arms	NOM	4.78	5.60	9.20	4.50	4.50	4.50
Peak Stall Torque (25°C winding temp)	Tp	Nm	NOM	113	113	113	153	153	153
		lb-ft		83.0	83.0	83.0	113	113	113
Peak Current	Ip	Arms	NOM	18.0	22.8	36.2	18.0	22.8	36.2
Rated Continuous Output Power at 25°C Amb. (1)	P Rated	Watts		2600	2600	2600	2500	2550	2500
	HP Rated	HP		3.49	3.49	3.49	3.35	3.42	3.35
Speed at Rated Power	N Rated	RPM		830	830	830	620	620	620
Torque Sensitivity (2)	Kt	Nm / Arms	+/-10%	7.74	6.45	3.87	10.1	8.44	5.06
		lb-ft / Arms		5.71	4.76	2.85	7.47	6.23	3.74
Back EMF Constant	Kb	Vrms / kRPM	+/- 10%	468	390	234	612	511	306
Motor Constant	Km	Nm/√watt	+/-10%	2.39	2.45	2.39	2.79	2.86	2.79
		lb-ft /√watt		1.77	1.81	1.77	2.06	2.11	2.06
Resistance (line to line)	Rm	Ohms	+/- 10%	6.96	4.61	1.73	8.76	5.80	2.18
Inductance	Lm	mH		33	23	8.3	48	33	12
Inertia (KBM)	Jm	Kg-m ²		6.44E-03			8.54E-03		
		lb-ft-s ²		4.75E-03			6.30E-03		
Weight (KBM)	Wt	Kg		8.85			11.80		
		lb		19.5			25.9		
Inertia (KBMS)	Jm	Kg-m ²		6.85E-03			9.44E-03		
		lb-ft-s ²		5.05E-03			6.96E-03		
Weight (KBMS)	Wt	Kg		9.25			12.20		
		lb		20.4			26.90		
Max Static Friction	Tf	Nm		0.353			0.479		
		lb-ft		0.260			0.353		
Cogging Friction (peak-to-peak)	Tcog	Nm		0.176			0.240		
		lb-ft		0.130			0.177		
Viscous Damping	Fi	Nm/ kRPM		1.49			2.03		
		lb-ft / kRPM		1.10			1.50		
Thermal Resistance (3)	TPR	°C / watt		0.396			0.339		
Number of Poles	P	-		16			16		
Recommended Kollmorgen AKD Drive				00607	00607	01206	00607	00607	01206
Voltage Req'd at Rated Output	Vac Input	Vac		480	400	240	480	400	240
Peak Stall Torque (4) (Motor with Drive)	Tp Drive	Nm	+/-10%	113	96.6	96.2	153	127	126
		lb-ft		83.3	71.2	71.0	113	93.7	92.9
Cont. Stall Torque (4) (Motor with Drive)	Tc Drive	Nm	+/-10%	35.1	35.1	35.1	44.2	44.2	44.2
		lb-ft		25.9	25.9	25.9	32.6	32.6	32.6

- Notes
- 1) Winding temperature = 155°C at continuous stall, at rated output, and for performance curves.
 - 2) To calculate no-load Kt and Kb at 25°C, multiply by 1.064.
 - 3) TPR assumes motor is housed and mounted to a 18" x 18" x 1/2" heat sink or equivalent.
 - 4) Peak & Continuous Torques may be limited by drive current, see www.kollmorgen.com for complete drive ratings.

KBM 43 Performance Curves

Continuous duty capability for 130°C rise in a 25°C ambient using recommended AKD servo drive and sinusoidal commutation.

**KBM(S)-43X01
Continuous Torque**

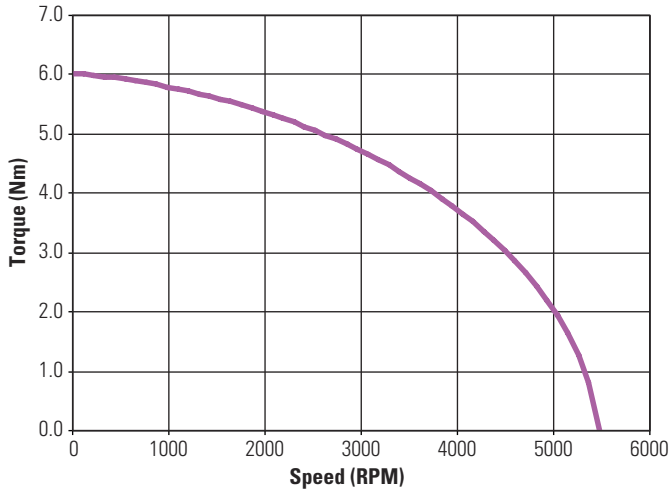

— A Winding-400 Vac / B Winding-240 Vac / C Winding-120 Vac

**KBM(S)-43X02
Continuous Torque**

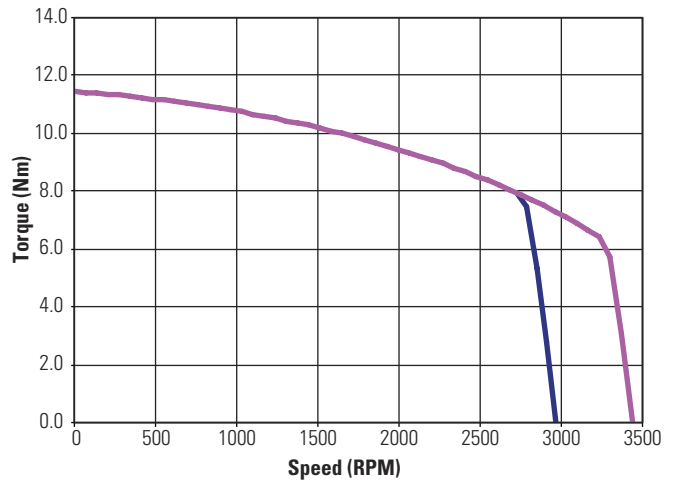

— A Winding-480 Vac / C Winding-400 Vac / D Winding-240 Vac
— B Winding-120 Vac

**KBM(S)-43X03
Continuous Torque**

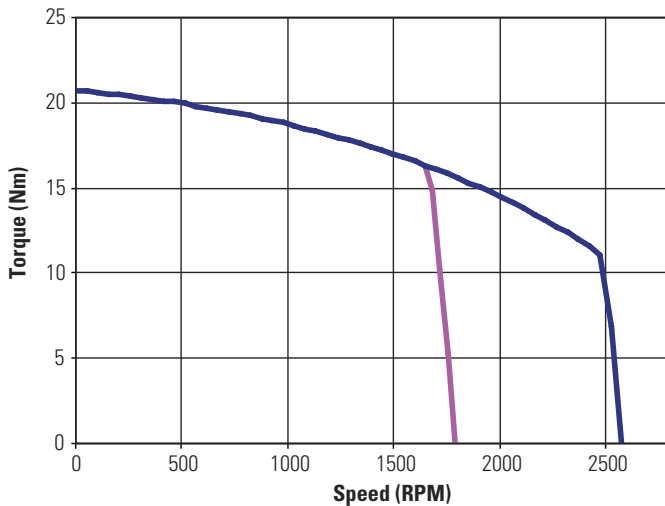

— A Winding-480 Vac / C Winding-400 Vac / D Winding-120 Vac
— B Winding-240 Vac

**KBM(S)-43X04
Continuous Torque**

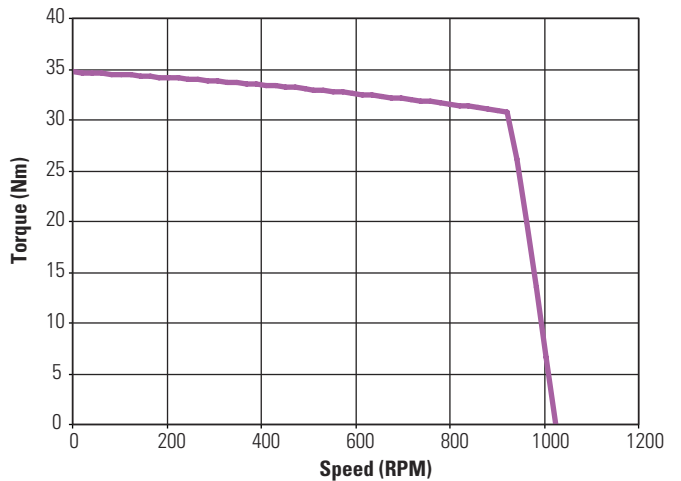

— A Winding-480 Vac / B Winding-400 Vac / C Winding-240 Vac

Low Voltage optimized windings available.

**KBM(S)-43X05
Continuous Torque**

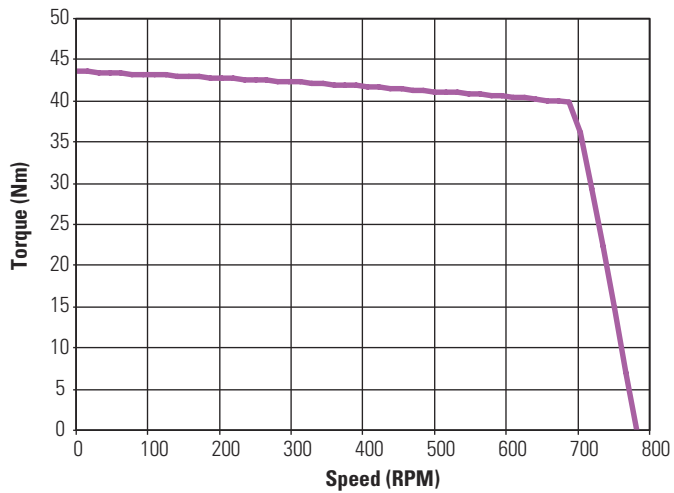

— A Winding-480 Vac / B Winding-400 Vac / C Winding-240 Vac

Low Voltage optimized windings available.

Notes

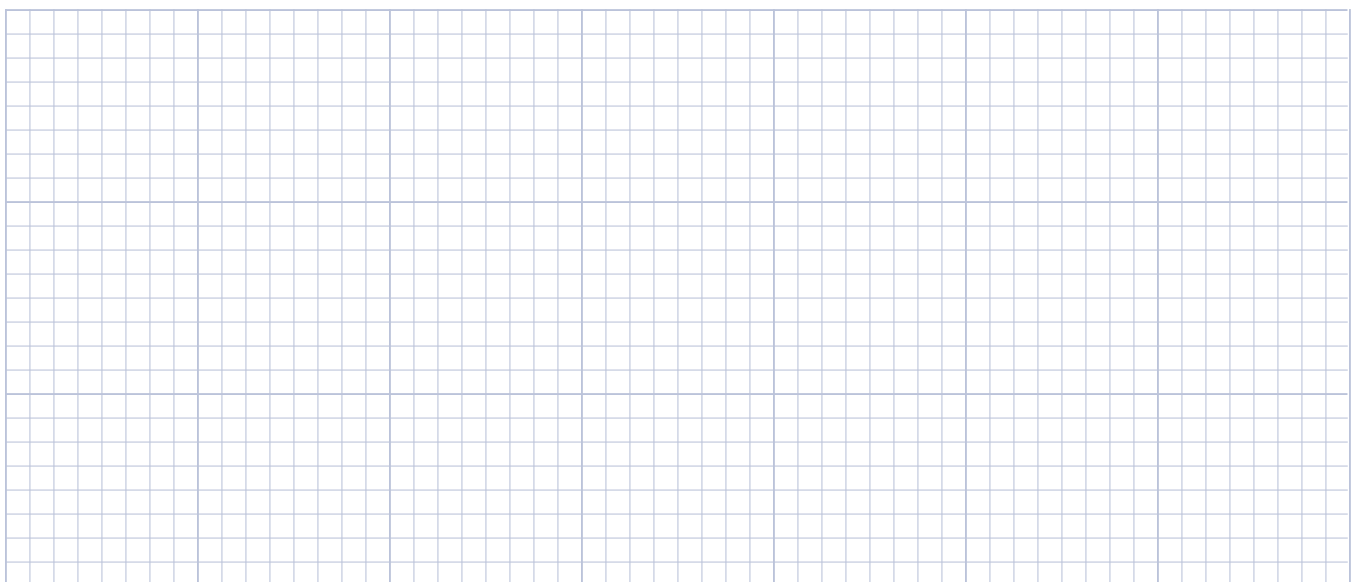

KBM 45 Frameless Motors

The KBM(S)-45 series is designed to operate over a broad speed range with high acceleration. Designed for maximum torque density with minimal cogging by using a variable air gap, the KBM(S)-45 is an ideal choice to meet or exceed your compact frameless motor application needs.

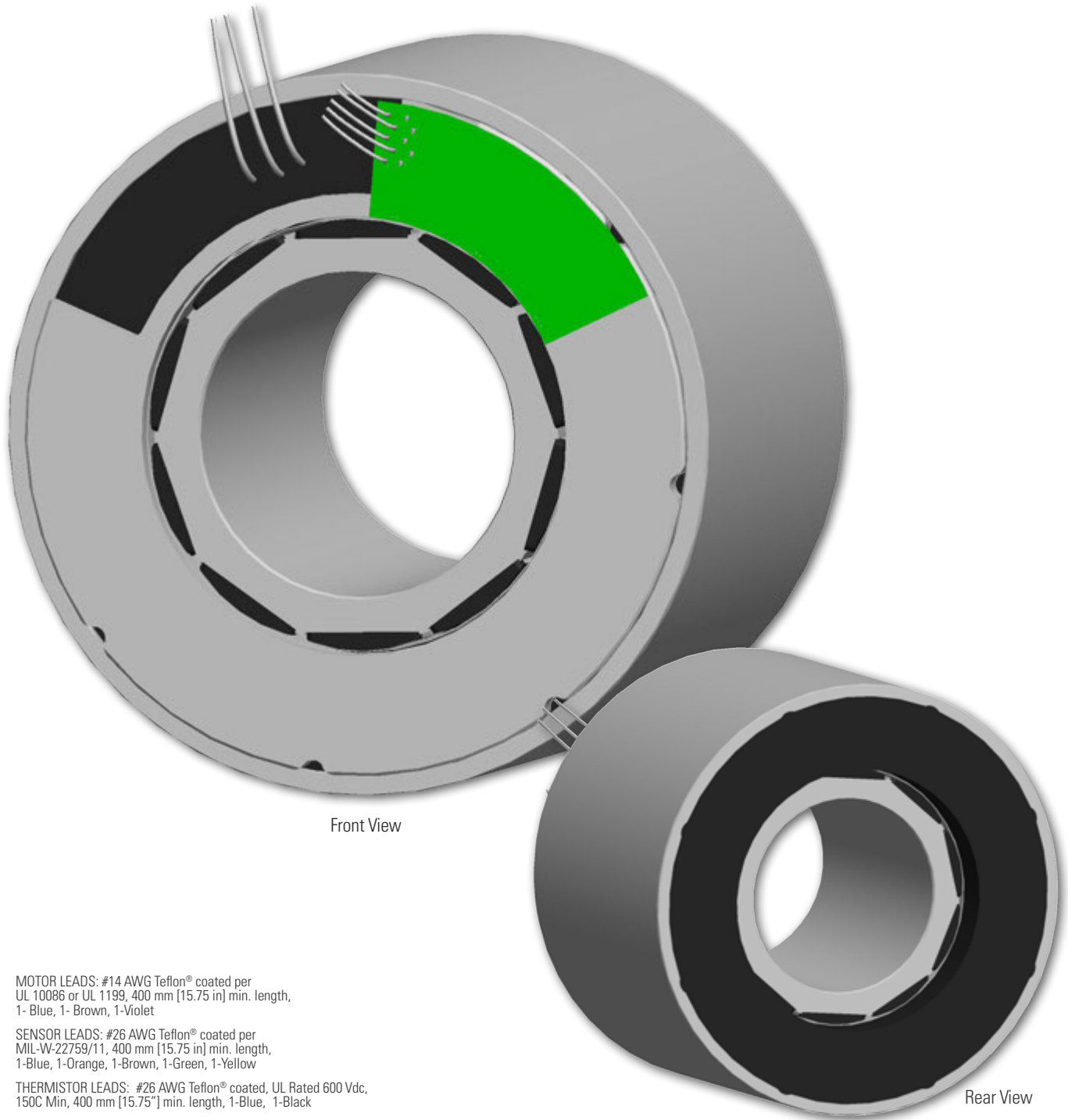

KBM 45 Outline Drawings

KBM 45

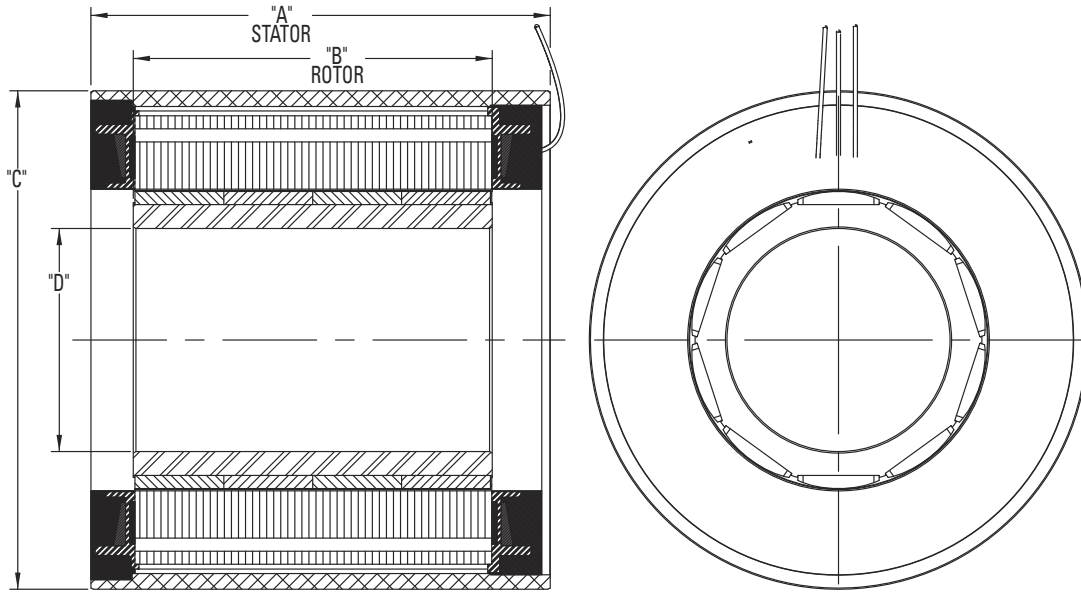

Model Number	"A" mm[inch]	"B" mm[inch]	Ø "C" mm[inch]	Ø "D" mm[inch]
KBM-45X01	107.06 [4.215]	69.04 [2.718]	189.956 [7.4786]	85.018 [3.3471]
KBM-45X02	141.06 [5.554]			
KBM-45X03	175.05 [6.892]			

All dimensions are nominal. For more detailed and interactive 3D models with 2D product views, visit www.kollmorgen.com/kbm

KBMS 45

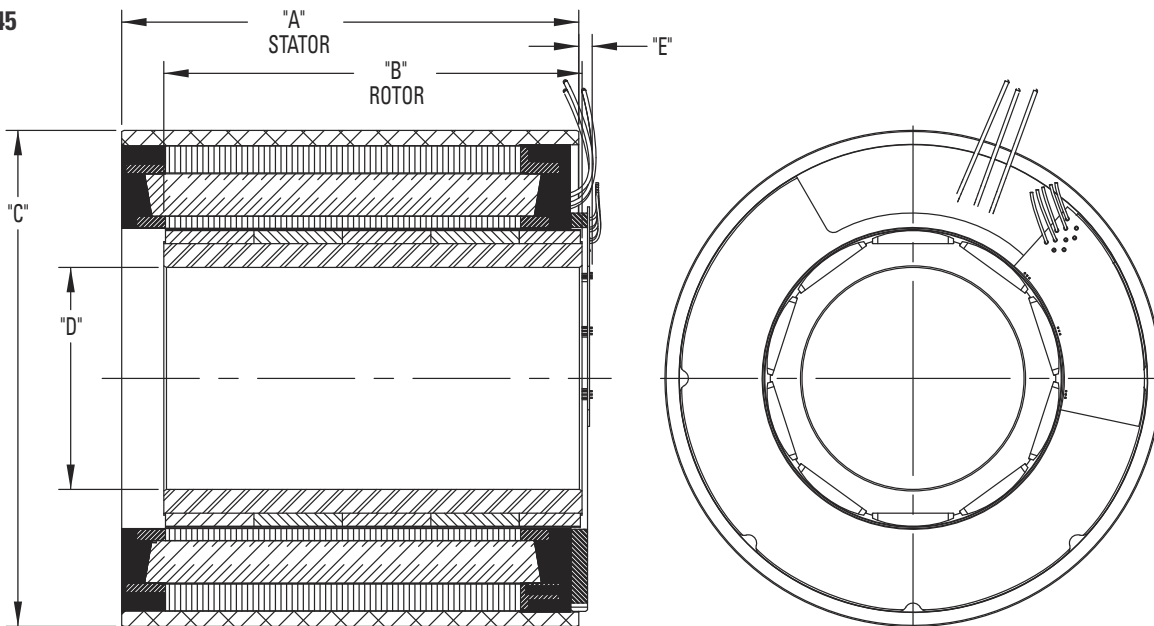

Model Number	"A" mm[inch]	"B" mm[inch]	Ø "C" mm[inch]	Ø "D" mm[inch]	"E" MAX mm[inch]
KBMS-45X01	107.06 [4.215]	92.41 [3.638]	189.956 [7.4786]	85.018 [3.3471]	5.75 [.226]
KBMS-45X02	141.06 [5.554]	126.29 [4.972]			
KBMS-45X03	175.05 [6.892]	160.17 [6.306]			

All dimensions are nominal. For more detailed and interactive 3D models with 2D product views, visit www.kollmorgen.com/kbm

KBM 45 Performance Data

KBM(S)-45XXX PERFORMANCE DATA & MOTOR PARAMETERS														
Motor Parameter	Symbol	Units	TOL	KBM(S)-45X01-X				KBM(S)-45X02-X			KBM(S)-45X03-X			
				A	B	C	D	A	B	C	A	B		
Continuous Stall Torque at 25°C Amb. (1)	Tc	Nm	NOM	30.7	30.2	31.3	29.7	43.7	43.5	41.9	54.6	53.0		
		lb-ft		22.6	22.3	23.1	21.9	32.3	32.1	30.9	40.3	39.1		
Continuous Current	Ic	Arms	NOM	10.2	12.5	14.3	20.2	13.3	14.9	21.1	14.1	19.9		
Peak Stall Torque (25°C winding temp)	Tp	Nm	NOM	119	119	119	118	170	171	168	218	215		
		lb-ft		87.6	87.6	88.0	86.7	126	126	124	161	159		
Peak Current	Ip	Arms	NOM	46.5	57.5	65.0	93.5	60.5	68.0	97.2	64.5	92.5		
Rated Continuous Output Power at 25°C Amb. (1)	P Rated	Watts		5200	5750	6045	4930	6655	7200	4525	6500	7270	7580	7670
	HP Rated	HP		6.97	7.71	8.10	6.61	8.92	9.65	6.07	8.71	9.75	10.2	10.3
Speed at Rated Power	N Rated	RPM		2100	2650	3100	3700	1950	2350	3500	2830	1700	2600	2050
Torque Sensitivity (2)	Kt	Nm / Arms	+/-10%	3.08	2.48	2.24	1.51	3.35	2.98	2.03	3.96	2.72		
		lb-ft / Arms		2.27	1.83	1.65	1.12	2.47	2.20	1.50	2.92	2.01		
Back EMF Constant	Kb	Vrms/kRPM	+/- 10%	186	150	135	91	202	180	123	240	165		
Motor Constant	Km	Nm/√watt	+/-10%	2.16	2.11	2.20	2.09	2.80	2.79	2.69	3.36	3.24		
		lb-ft / √watt		1.59	1.56	1.62	1.54	2.07	2.06	1.99	2.48	2.39		
Resistance (line to line)	Rm	Ohms	+/- 10%	1.36	0.920	0.690	0.350	0.950	0.760	0.380	0.930	0.470		
Inductance	Lm	mH		21	14	11	5.0	16	12	5.9	16	7.7		
Inertia (KBM)	Jm	Kg-m ²		6.10E-3				9.22E-3			1.22E-2			
		lb-ft-s ²		4.50E-3				6.80E-3			9.00E-3			
Weight (KBM)	Wt	Kg		12.2				17.5			23.1			
		lb		26.9				38.6			51.0			
Inertia (KBMS)	Jm	Kg-m ²		8.35E-3				1.15E-2			1.45E-2			
		lb-ft-s ²		6.16E-3				8.47E-3			1.07E-2			
Weight (KBMS)	Wt	Kg		13.2				18.5			24.2			
		lb		29.0				40.7			53.3			
Max Static Friction	Tf	Nm		0.750				0.850			1.09			
		lb-ft		0.553				0.627			0.806			
Cogging Friction (peak-to-peak)	Tcog	Nm		0.630				0.671			0.846			
		lb-ft		0.465				0.495			0.624			
Viscous Damping	Fi	Nm/ kRPM		5.64E-2				0.122			0.188			
		lb-ft / kRPM		4.16E-2				9.01E-2			0.139			
Thermal Resistance (3)	TPR	°C / watt		0.390				0.330			0.300			
Number of Poles	P	-		10				10			10			
Recommended Kollmorgen AKD Drive				01207	02407	02407	02407	02407	02407	02407	02407	02407	02407	
Voltage Req'd at Rated Output	Vac Input	Vac		480	480	480	400	480	480	480	400	480	480	400
Peak Stall Torque (4) (Motor with Drive)	Tp Drive	Nm	+/-10%	83.3	103	96.3	67.0	140	129	91.0	91.0	169	121	121
		lb-ft		61.4	76.0	71.0	49.4	103	95.1	67.1	67.1	125	89.2	89.2
Cont. Stall Torque (4) (Motor with Drive)	Tc Drive	Nm	+/-10%	30.7	30.2	31.3	29.7	43.7	43.5	41.9	41.9	54.6	53.0	53.0
		lb-ft		22.6	22.3	23.1	21.9	32.2	32.1	30.9	30.9	40.3	39.1	39.1

- Notes
- 1) Winding temperature = 155°C at continuous stall, at rated output, and for performance curves.
 - 2) To calculate no-load Kt and Kb at 25°C, multiply by 1.064.
 - 3) TPR assumes motor is housed and mounted to a 18" x 18" x 1/2" heat sink or equivalent.
 - 4) Peak & Continuous Torques may be limited by drive current, see www.kollmorgen.com for complete drive ratings.

KBM 45 Performance Curves

Continuous duty capability for 130°C rise in a 25°C ambient using recommended AKD servo drive and sinusoidal commutation.

**KBM(S)-45X01
Continuous Torque**

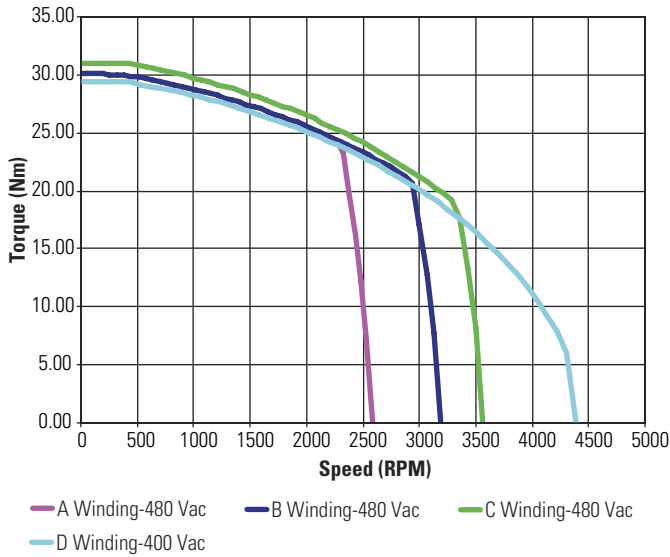

**KBM(S)-45X02
Continuous Torque**

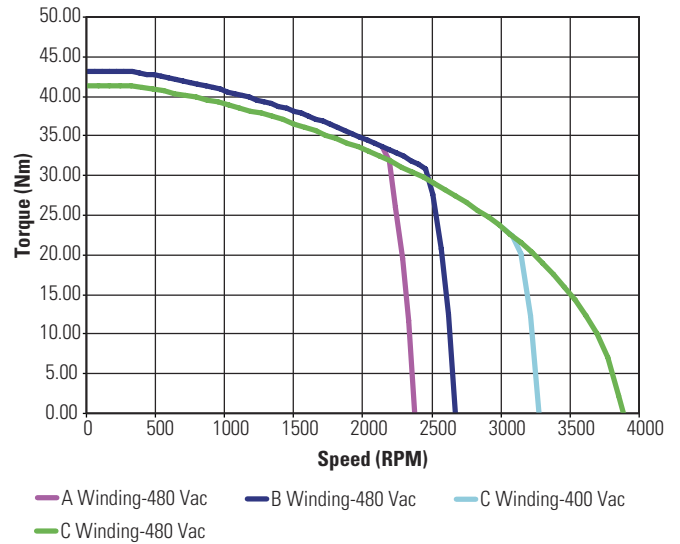

**KBM(S)-45X03
Continuous Torque**

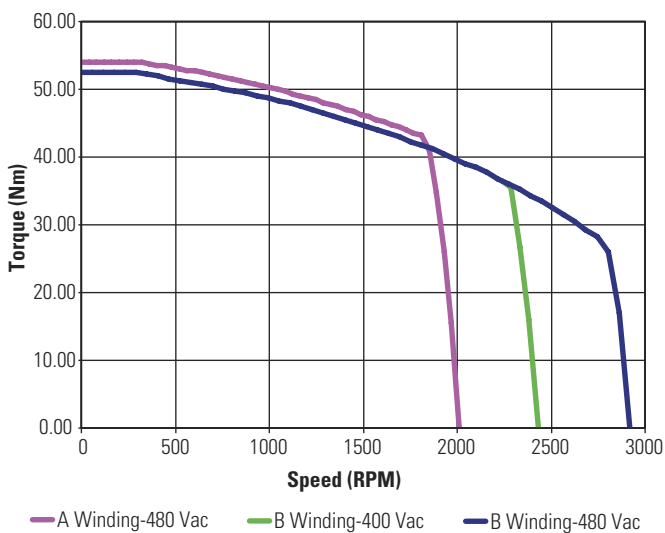

Low Voltage optimized windings available.

KBM 57 Frameless Motors

The KBM(S)-57 series provides a classic torque motor footprint - large diameter with a short axial length. With a skewed stator, low cogging, and low harmonic distortion these motors produce extremely smooth rotation. In addition, the high pole count and excellent torque / volume ratio makes the KBM(S)-57 an ideal fit for direct drive applications requiring high torque at low to moderate speeds.

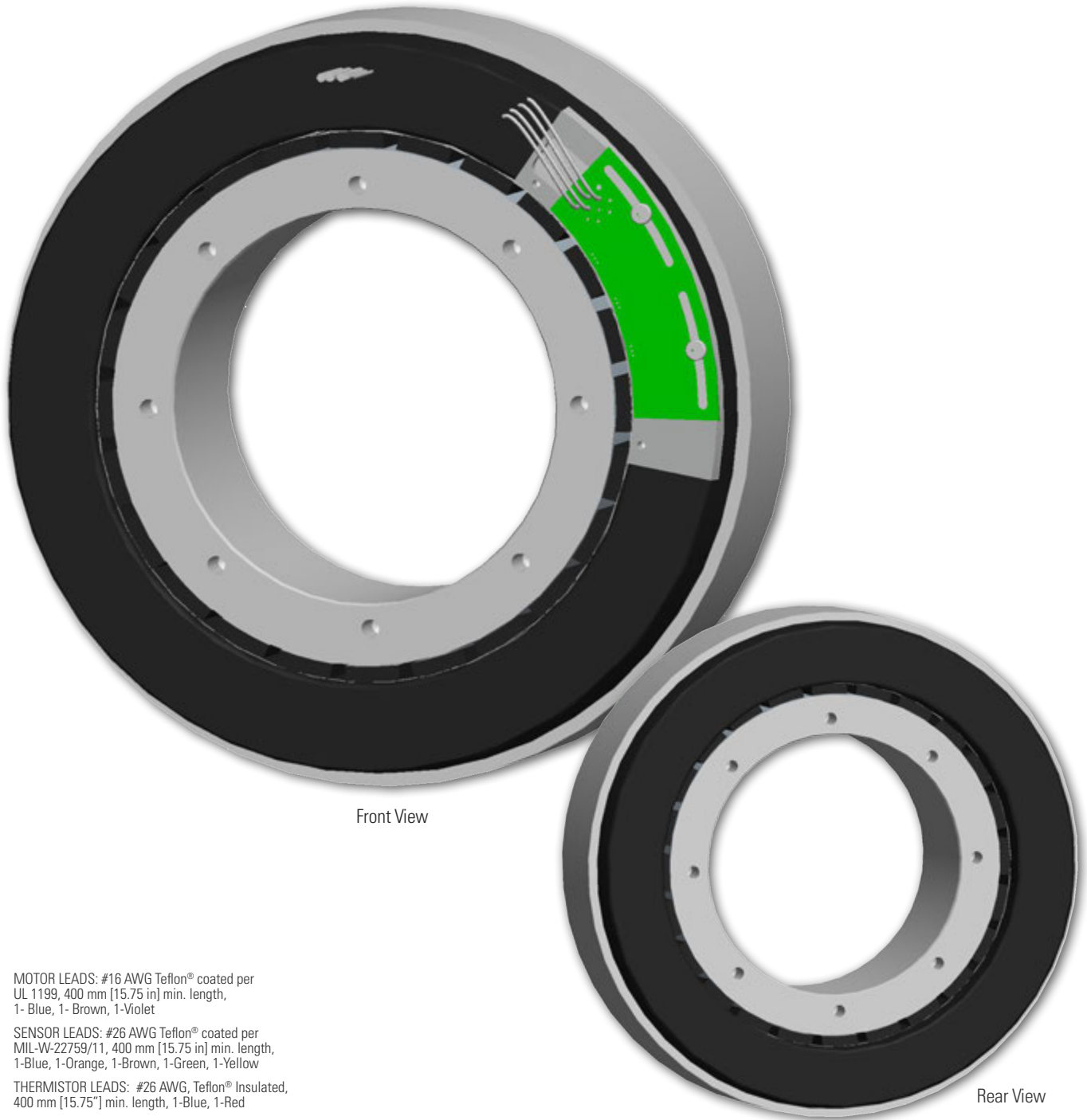

MOTOR LEADS: #16 AWG Teflon® coated per UL 1199, 400 mm [15.75 in] min. length, 1-Blue, 1-Brown, 1-Violet

SENSOR LEADS: #26 AWG Teflon® coated per MIL-W-22759/11, 400 mm [15.75 in] min. length, 1-Blue, 1-Orange, 1-Brown, 1-Green, 1-Yellow

THERMISTOR LEADS: #26 AWG, Teflon® Insulated, 400 mm [15.75"] min. length, 1-Blue, 1-Red

Rear View

KBM 57 Outline Drawings

KBM 57

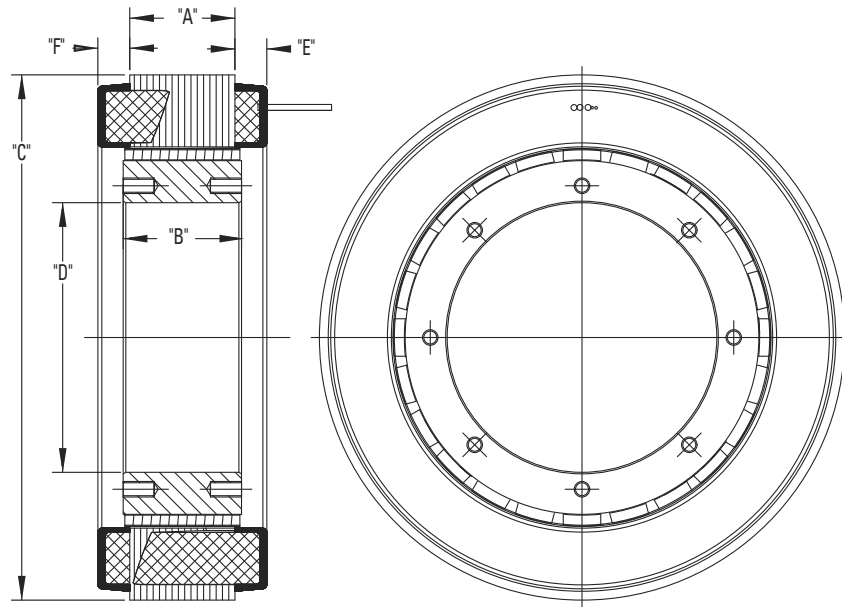

Model Number	"A" mm[inch]	"B" mm[inch]	Ø "C" mm[inch]	Ø "D" mm[inch]	"E" MAX mm[inch]	"F" MAX mm[inch]
KBM-57X01	20.32 [.800]	25.40 [1.000]	202.90 [7.988]	104.17 [4.101]	12.32 [.485]	12.32 [.485]
KBM-57X02	40.64 [1.600]	45.72 [1.800]				
KBM-57X03	81.79 [3.220]	86.36 [3.400]				
KBM-57X04	123.82 [4.875]	129.16 [5.085]				
KBM-57X05	166.37 [6.550]	171.70 [6.760]				

All dimensions are nominal. For more detailed and interactive 3D models with 2D product views, visit www.kollmorgen.com/kbm

KBMS 57

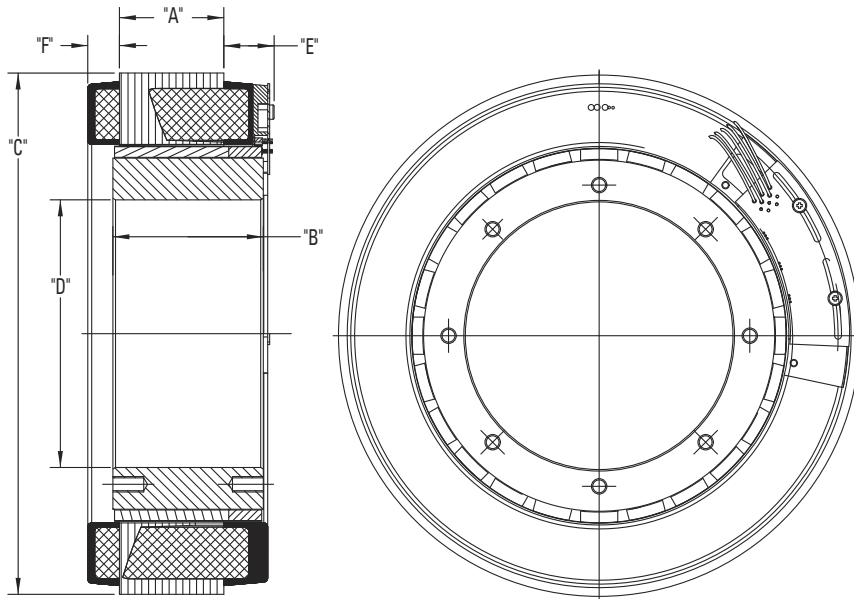

Model Number	"A" mm[inch]	"B" mm[inch]	Ø "C" mm[inch]	Ø "D" mm[inch]	"E" MAX mm[inch]	"F" MAX mm[inch]
KBMS-57X01	20.32 [.800]	38.23 [1.505]	202.90 [7.988]	104.17 [4.101]	20.32 [.800]	12.32 [.485]
KBMS-57X02	40.64 [1.600]	58.54 [2.305]				
KBMS-57X03	81.79 [3.220]	99.44 [3.915]				
KBMS-57X04	123.82 [4.875]	141.98 [5.590]				
KBMS-57X05	166.37 [6.550]	184.53 [7.265]				

All dimensions are nominal. For more detailed and interactive 3D models with 2D product views, visit www.kollmorgen.com/kbm

KBM 57 Performance Data

K B M 5 7 P E R F O R M A N C E D A T A

KBM(S)-57XXX PERFORMANCE DATA & MOTOR PARAMETERS												
Motor Parameter	Symbol	Units	TOL	KBM(S)-57X01-X			KBM(S)-57X02-X			KBM(S)-57X03-X		
				A	B	C	A	B	C	A	B	C
Continuous Stall Torque at 25°C Amb. (1)	Tc	Nm	NOM	18.8	18.8	18.8	33.5	33.5	33.5	60.0	60.0	60.0
		lb-ft		13.9	13.9	13.9	24.7	24.7	24.7	44.2	44.2	44.2
Continuous Current	Ic	Arms	NOM	5.68	6.90	11.4	5.23	6.24	11.0	5.47	6.70	11.0
Peak Stall Torque (25°C winding temp)	Tp	Nm	NOM	60.0	60.0	60.0	115	115	115	218	218	218
		lb-ft		44.2	44.2	44.2	85.0	85.0	85.0	161	161	161
Peak Current	Ip	Arms	NOM	23.4	27.9	47.0	23.4	27.9	47.0	26.1	32.9	52.4
Rated Continuous Output Power at 25°C Amb. (1)	P Rated	Watts		2310	2310	2310	2660	2660	2660	3000	3000	3000
	HP Rated	HP		3.10	3.10	3.10	3.57	3.57	3.57	4.02	4.02	4.00
Speed at Rated Power	N Rated	RPM		2050	2050	2050	1015	1015	1015	580	580	580
Torque Sensitivity (2)	Kt	Nm / Arms	+/-10%	3.35	2.76	1.68	6.46	5.42	3.23	11.1	9.08	5.53
		lb-ft / Arms		2.47	2.04	1.24	4.76	4.00	2.38	8.16	6.70	4.08
Back EMF Constant	Kb	Vrms/kRPM	+/- 10%	203	167	101	390	327	195	669	549	334
Motor Constant	Km	Nm/√watt	+/-10%	1.49	1.49	1.49	2.51	2.51	2.51	3.71	3.71	3.71
		lb-ft/√watt		1.10	1.10	1.10	1.85	1.85	1.85	2.74	2.74	2.74
Resistance (line to line)	Rm	Ohms	+/- 10%	3.39	2.21	0.845	4.40	2.93	1.10	5.92	3.86	1.48
Inductance	Lm	mH		13	9.1	3.4	22	15	5.4	35	23	8.6
Inertia (KBM)	Jm	Kg-m ²		6.56E-3			1.18E-2			2.21E-2		
		lb-ft-s ²		4.84E-3			8.70E-3			1.63E-2		
Weight (KBM)	Wt	Kg		4.54			7.89			14.5		
		lb		10.0			17.4			32.0		
Inertia (KBMS)	Jm	Kg-m ²		9.49E-3			1.49E-2			2.52E-2		
		lb-ft-s ²		7.00E-3			1.10E-2			1.86E-2		
Weight (KBMS)	Wt	Kg		5.31			8.62			15.4		
		lb		11.7			19.0			34.0		
Max Static Friction	Tf	Nm		0.176			0.285			0.556		
		lb-ft		0.130			0.210			0.410		
Cogging Friction (peak-to-peak)	Tcog	Nm		0.088			0.149			0.285		
		lb-ft		0.065			0.110			0.210		
Viscous Damping	Fi	Nm/ kRPM		6.51			3.97			3.99		
		lb-ft / kRPM		4.80			2.93			2.94		
Thermal Resistance (3)	TPR	°C / watt		0.530			0.480			0.326		
Number of Poles	P	-		24			24			24		
Recommended Kollmorgen AKD Drive				00607	01207	02406	00607	01207	02406	00607	01207	02406
Voltage Req'd at Rated Output	Vac Input	Vac		480	400	240	480	400	240	480	400	240
Peak Stall Torque (4) (Motor with Drive)	Tp Drive	Nm	+/-10%	46.1	60.0	60.0	90.5	115	115	173	205	198
		lb-ft		34.0	44.2	44.2	66.8	85.0	85.0	128	151	146
Cont. Stall Torque (4) (Motor with Drive)	Tc Drive	Nm	+/-10%	18.8	18.8	18.8	33.5	33.5	33.5	60.0	60.0	60.0
		lb-ft		13.87	13.9	13.9	24.7	24.7	24.7	44.3	44.3	44.3

- Notes
- 1) Winding temperature = 155°C at continuous stall, at rated output, and for performance curves.
 - 2) To calculate no-load Kt and Kb at 25°C, multiply by 1.064.
 - 3) TPR assumes motor is housed and mounted to a 12" x 12" x 3/4" heat sink or equivalent.
 - 4) Peak & Continuous Torques may be limited by drive current, see www.kollmorgen.com for complete drive ratings.

KBM(S)-57XXX PERFORMANCE DATA & MOTOR PARAMETERS									
Motor Parameter	Symbol	Units	TOL	KBM(S)-57X04-X			KBM(S)-57X05-X		
				A	B	C	A	B	C
Continuous Stall Torque at 25°C Amb. (1)	Tc	Nm	NOM	85.3	85.3	85.3	109	109	109
		lb-ft		62.9	62.9	62.9	80.1	80.1	80.1
Continuous Current	Ic	Arms	NOM	5.20	6.50	10.6	5.00	6.20	10.0
Peak Stall Torque (25°C winding temp)	Tp	Nm	NOM	332	332	332	441	441	441
		lb-ft		245	245	245	325	325	325
Peak Current	Ip	Arms	NOM	26.1	32.9	52.4	26.1	32.9	52.4
Rated Continuous Output Power at 25°C Amb. (1)	P Rated	Watts		2880	2880	2880	2675	2675	2675
	HP Rated	HP		3.86	3.86	3.86	3.59	3.59	3.59
Speed at Rated Power	N Rated	RPM		375	375	375	265	265	265
Torque Sensitivity (2)	Kt	Nm / Arms	+/-10%	16.7	13.7	8.37	22.4	18.4	11.2
		lb-ft / Arms		12.3	10.1	6.17	16.5	13.6	8.27
Back EMF Constant	Kb	Vrms / kRPM	+/- 10%	1011	832	506	1356	1113	677
Motor Constant	Km	Nm/√watt	+/-10%	4.77	4.77	4.77	5.64	5.64	5.64
		lb-ft /√watt		3.52	3.52	3.52	4.16	4.16	4.16
Resistance (line to line)	Rm	Ohms	+/- 10%	8.22	5.36	2.05	10.5	6.86	2.63
Inductance	Lm	mH		52	35	13	70	47	18
Inertia (KBM)	Jm	Kg-m ²		3.44E-02			4.58E-02		
		lb-ft-s ²		2.54E-02			3.38E-02		
Weight (KBM)	Wt	Kg		22.0			29.2		
		lb		48.5			64.3		
Inertia (KBMS)	Jm	Kg-m ²		3.78E-02			4.91E-02		
		lb-ft-s ²		2.79E-02			3.62E-02		
Weight (KBMS)	Wt	Kg		22.9			30.1		
		lb		50.4			66.3		
Max Static Friction	Tf	Nm		0.881			1.13		
		lb-ft		0.650			0.834		
Cogging Friction (peak-to-peak)	Tcog	Nm		0.441			0.569		
		lb-ft		0.325			0.420		
Viscous Damping	Fi	Nm/ kRPM		5.97			8.41		
		lb-ft / kRPM		4.40			6.20		
Thermal Resistance (3)	TPR	°C / watt		0.265			0.229		
Number of Poles	P	-		24			24		
Recommended Kollmorgen AKD Drive				00607	01207	02406	00607	01207	02406
Voltage Req'd at Rated Output	Vac Input	Vac		480	400	240	480	400	240
Peak Stall Torque (4) (Motor with Drive)	Tp Drive	Nm	+/-10%	241	311	301	323	416	402
		lb-ft		178	229	222	238	307	297
Cont. Stall Torque (4) (Motor with Drive)	Tc Drive	Nm	+/-10%	85.3	85.3	85.3	109	109	109
		lb-ft		62.9	62.9	62.9	80.4	80.4	80.4

- Notes
- 1) Winding temperature = 155°C at continuous stall, at rated output, and for performance curves.
 - 2) To calculate no-load Kt and Kb at 25°C, multiply by 1.064.
 - 3) TPR assumes motor is housed and mounted to a 12" x 12" x 3/4" heat sink or equivalent.
 - 4) Peak & Continuous Torques may be limited by drive current, see www.kollmorgen.com for complete drive ratings.

KBM 57 Performance Curves

Continuous duty capability for 130°C rise in a 25°C ambient using recommended AKD servo drive and sinusoidal commutation.

**KBM(S)-57X01
Continuous Torque**

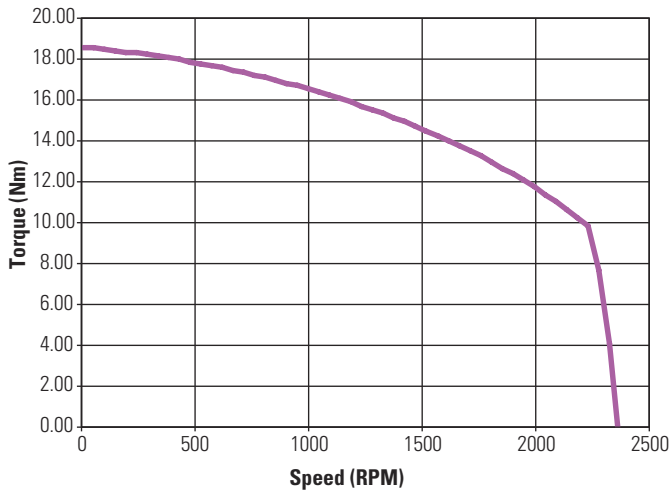

— A Winding-480 VAC / B Winding-400 VAC / C Winding-240 VAC

**KBM(S)-57X02
Continuous Torque**

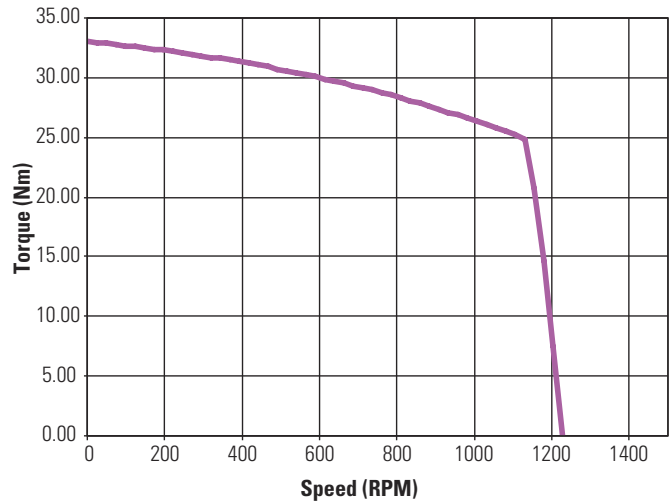

— A Winding-480 Vac / B Winding-400 Vac / C Winding-240 Vac

**KBM(S)-57X03
Continuous Torque**

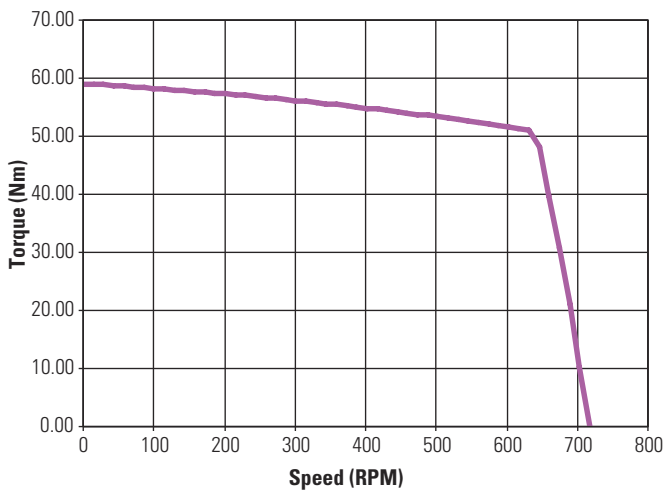

— A Winding-480 Vac / B Winding-400 Vac / C Winding-240 Vac

**KBM(S)-57X04
Continuous Torque**

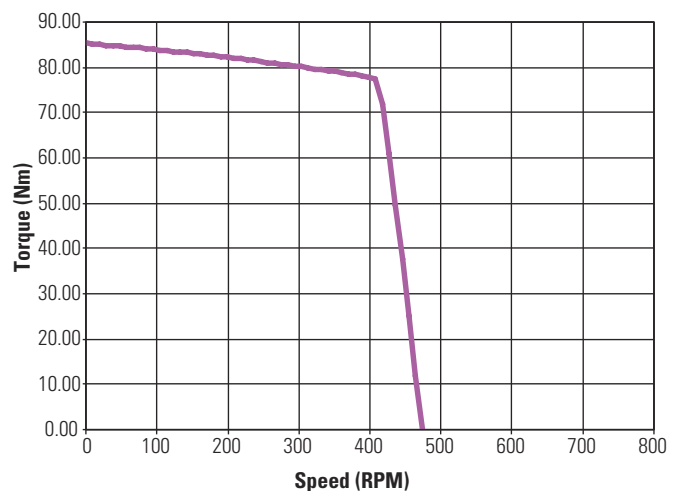

— A Winding-480 Vac / B Winding-400 Vac / C Winding-240 Vac

Low Voltage optimized windings available.

**KBM(S)-57X05
Continuous Torque**

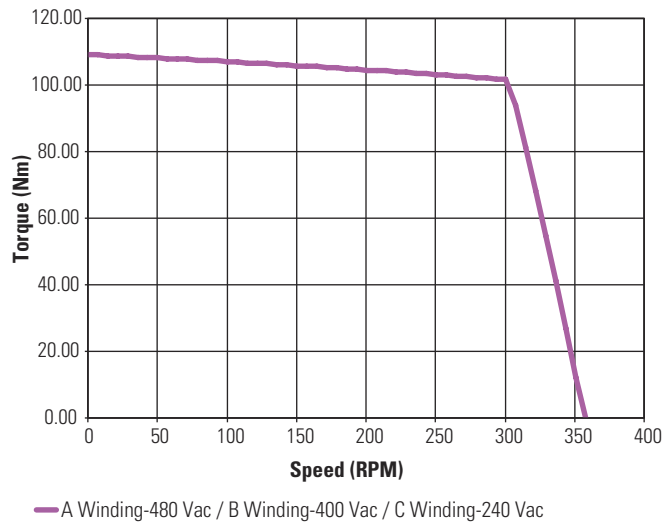

Low Voltage optimized windings available.

Notes

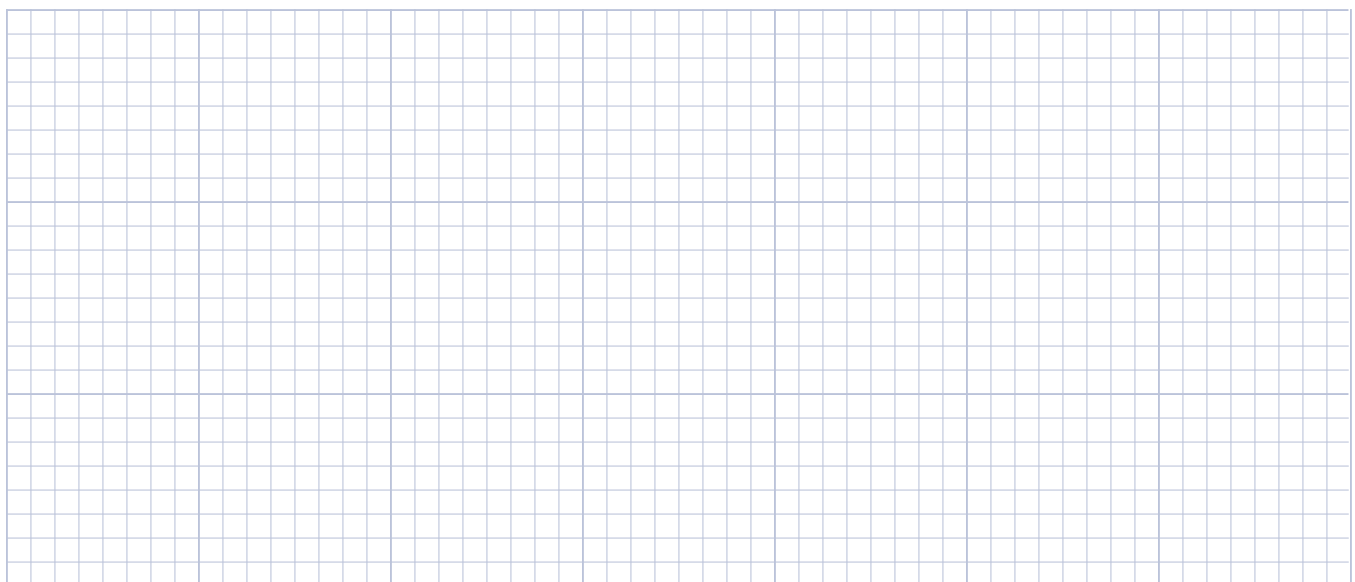

KBM 60 Frameless Motors

K B M 6 0

The KBM(S)-60 series has an optimized slot / pole combination offering extremely high continuous torque capability while still maintaining very low total harmonic distortion. The higher pole count and excellent torque / volume ratio makes the KBM(S)-60 an ideal fit for direct drive applications requiring high torque at low to moderate speeds.

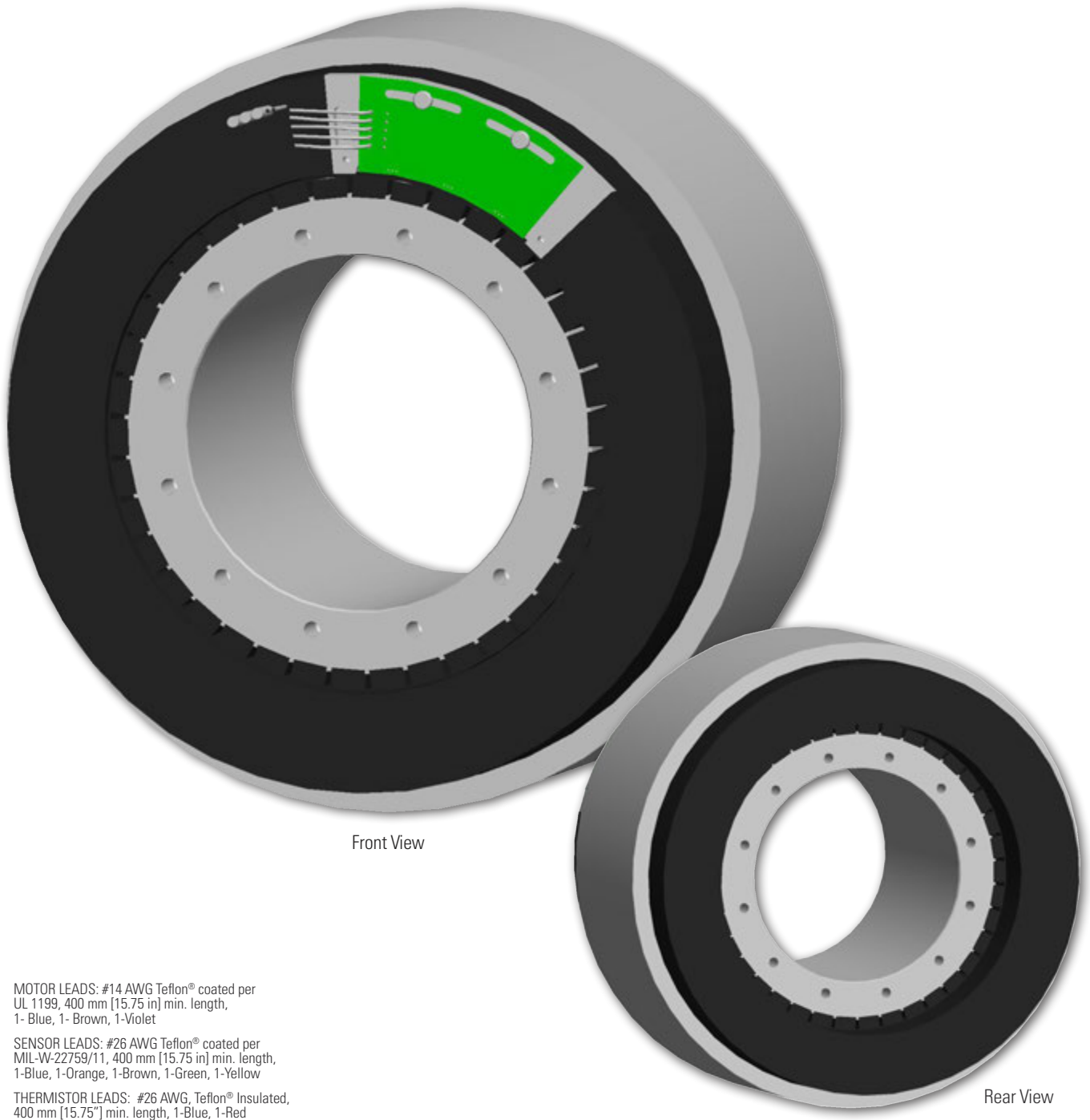

Front View

Rear View

MOTOR LEADS: #14 AWG Teflon[®] coated per UL 1199, 400 mm [15.75 in] min. length, 1- Blue, 1- Brown, 1-Violet

SENSOR LEADS: #26 AWG Teflon[®] coated per MIL-W-22759/11, 400 mm [15.75 in] min. length, 1-Blue, 1-Orange, 1-Brown, 1-Green, 1-Yellow

THERMISTOR LEADS: #26 AWG, Teflon[®] Insulated, 400 mm [15.75"] min. length, 1-Blue, 1-Red

KBM 60 Outline Drawings

KBM 60

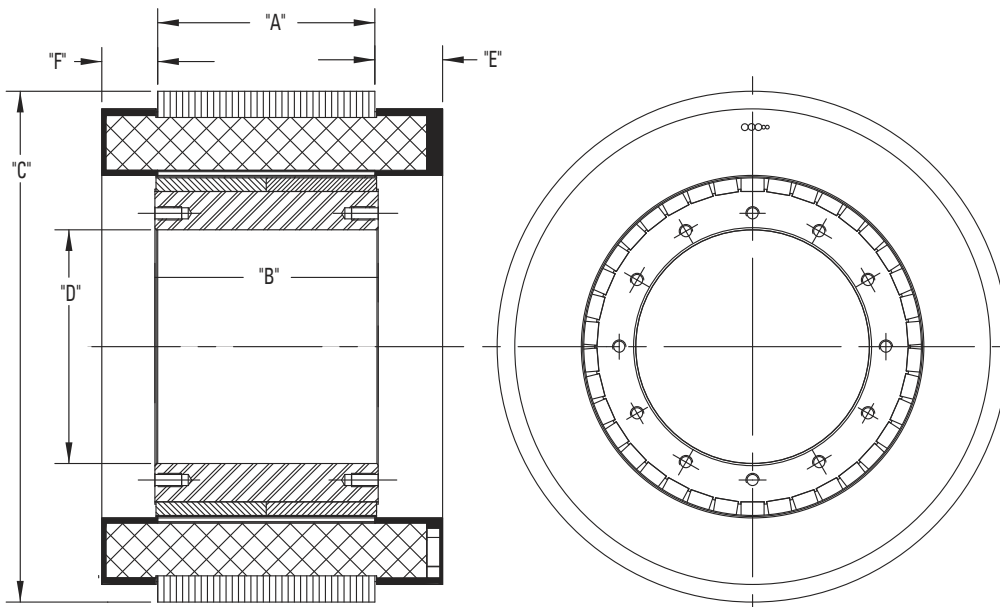

Model Number	"A" mm[inch]	"B" mm[inch]	Ø "C" mm[inch]	Ø "D" mm[inch]	"E" MAX mm[inch]	"F" MAX mm[inch]
KBM-60X00	26.62 [1.048]	29.39 [1.157]	229.85 [9.049]	105.05 [4.136]	30.48 [1.200]	25.15 [.990]
KBM-60X01	48.11 [1.894]	50.88 [2.003]				
KBM-60X02	97.71 [3.847]	100.48 [3.956]				
KBM-60X03	147.32 [5.800]	150.09 [5.909]				

All dimensions are nominal. For more detailed and interactive 3D models with 2D product views, visit www.kollmorgen.com/kbm

KBMS 60

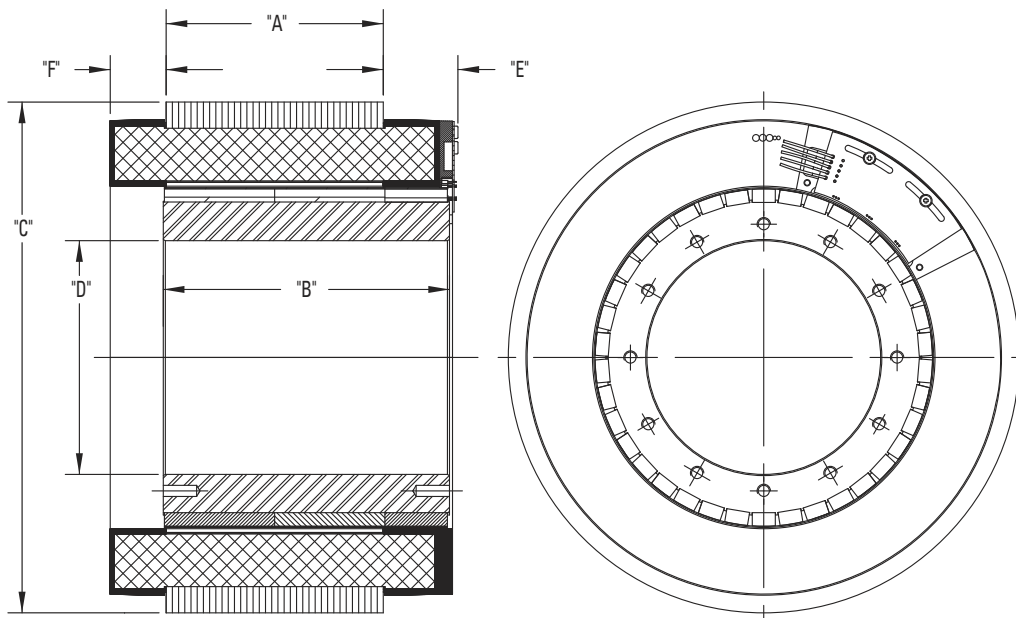

Model Number	"A" mm[inch]	"B" mm[inch]	Ø "C" mm[inch]	Ø "D" mm[inch]	"E" MAX mm[inch]	"F" MAX mm[inch]
KBMS-60X00	26.62 [1.048]	57.53 [2.265]	229.85 [9.049]	105.05 [4.136]	33.65 [1.325]	25.15 [.990]
KBMS-60X01	48.11 [1.894]	78.99 [3.110]				
KBMS-60X02	97.71 [3.847]	128.78 [5.070]				
KBMS-60X03	147.32 [5.800]	178.31 [7.020]				

All dimensions are nominal. For more detailed and interactive 3D models with 2D product views, visit www.kollmorgen.com/kbm

KBM 60 Performance Data

KBM(S)-60XXX PERFORMANCE DATA & MOTOR PARAMETERS									
Motor Parameter	Symbol	Units	TOL	KBM(S)-60X00-X			KBM(S)-60X01-X		
				A	B	C	A	B	C
Continuous Stall Torque at 25°C Amb. (1)	Tc	Nm	NOM	29.4	29.4	29.4	53.9	53.9	53.9
		lb-ft		21.7	21.7	21.7	39.8	39.8	39.8
Continuous Current	Ic	Arms	NOM	13.7	16.8	22.5	13.7	16.9	22.7
Peak Stall Torque (25°C winding temp)	Tp	Nm	NOM	69.1	69.1	69.1	127	127	127
		lb-ft		51.0	51.0	51.0	93.8	93.8	93.8
Peak Current	Ip	Arms	NOM	40.0	50.4	63.6	40.0	50.4	78.0
Rated Continuous Output Power at 25°C Amb. (1)	P Rated	Watts		2960	2960	2960	4165	4165	4580
	HP Rated	HP		3.97	3.97	3.97	5.58	5.58	6.14
Speed at Rated Power	N Rated	RPM		1700	1700	1700	1600	1600	1300
Torque Sensitivity (2)	Kt	Nm / Arms	+/-10%	2.23	1.81	1.35	4.04	3.27	2.43
		lb-ft / Arms		1.65	1.33	0.994	2.98	2.41	1.80
Back EMF Constant	Kb	Vrms/kRPM	+/- 10%	135	110	81.3	244	198	147
Motor Constant	Km	Nm/√watt	+/-10%	2.17	2.17	2.17	3.44	3.44	3.44
		lb-ft /√watt		1.60	1.60	1.60	2.54	2.54	2.54
Resistance (line to line)	Rm	Ohms	+/- 10%	0.704	0.453	0.267	0.916	0.590	0.335
Inductance	Lm	mH		4.5	3.0	1.6	8.0	5.1	2.8
Inertia (KBM)	Jm	Kg-m ²		9.53E-03			1.63E-02		
		lb-ft-s ²		7.03E-03			1.20E-2		
Weight (KBM)	Wt	Kg		8.30			13.2		
		lb		18.3			29.0		
Inertia (KBMS)	Jm	Kg-m ²		1.88E-02			2.56E-2		
		lb-ft-s ²		1.39E-02			1.89E-2		
Weight (KBMS)	Wt	Kg		10.4			15.3		
		lb		22.9			33.8		
Max Static Friction	Tf	Nm		0.750			1.36		
		lb-ft		0.550			1.00		
Cogging Friction (peak-to-peak)	Tcog	Nm		0.560			1.02		
		lb-ft		0.410			0.750		
Viscous Damping	Fi	Nm/ kRPM		0.870			0.230		
		lb-ft / kRPM		0.640			0.170		
Thermal Resistance (4)	TPR	°C / watt		0.452			0.336		
Number of Poles	P	-		38			38		
Recommended Kollmorgen AKD Drive				02407	02407	02406	02407	02407	02406
Voltage Req'd at Rated Output	Vac Input	Vac		480	400	240	480	400	240
Peak Stall Torque (4) (Motor with Drive)	Tp Drive	Nm	+/-10%	69.1	63.0	53.0	127	120	96
		lb-ft		51.0	46.5	39.1	93.8	88.5	70.8
Cont. Stall Torque (4) (Motor with Drive)	Tc Drive	Nm	+/-10%	29.4	29.4	29.4	53.9	53.9	53.9
		lb-ft		21.7	21.7	21.7	39.8	39.8	39.8

- Notes
- 1) Winding temperature = 155°C at continuous stall, at rated output, and for performance curves.
 - 2) To calculate no-load Kt and Kb at 25°C, multiply by 1.064.
 - 3) TPR assumes motor is housed and mounted to a 12" x 12" x 3/4" heat sink or equivalent.
 - 4) Peak & Continuous Torques may be limited by drive current, see www.kollmorgen.com for complete drive ratings.

KBM(S)-60XXX PERFORMANCE DATA & MOTOR PARAMETERS							
Motor Parameter	Symbol	Units	TOL	KBM(S)-60X02-X		KBM(S)-60X03-X	
				A	B	A	B
Continuous Stall Torque at 25°C Amb. (1)	Tc	Nm	NOM	108	108	154	154
		lb-ft		79.7	79.7	114	114
Continuous Current	Ic	Arms	NOM	16.3	19.6	18.6	24.0
Peak Stall Torque (25°C winding temp)	Tp	Nm	NOM	243	243	393	393
		lb-ft		179	179	290	290
Peak Current	Ip	Arms	NOM	50.4	60.4	63.3	76.8
Rated Continuous Output Power at 25°C Amb. (1)	P Rated	Watts		6985	6985	8350	8420
	HP Rated	HP		9.36	9.36	11.2	11.3
Speed at Rated Power	N Rated	RPM		885	885	720	730
Torque Sensitivity (2)	Kt	Nm / Arms	+/-10%	6.79	5.66	8.50	7.01
		lb-ft / Arms		5.01	4.17	6.27	5.17
Back EMF Constant	Kb	Vrms/kRPM	+/- 10%	411	342	514	424
Motor Constant	Km	Nm/√watt	+/-10%	5.78	5.78	7.46	7.39
		lb-ft /√watt		4.26	4.26	5.50	5.45
Resistance (line to line)	Rm	Ohms	+/- 10%	0.921	0.638	0.867	0.600
Inductance	Lm	mH		11	7.6	11	7.5
Inertia (KBM)	Jm	Kg-m ²		3.17E-2		4.75E-2	
		lb-ft-s ²		2.34E-2		3.50E-2	
Weight (KBM)	Wt	Kg		25.2		37.2	
		lb		55.6		82.0	
Inertia (KBMS)	Jm	Kg-m ²		4.20E-2		5.29E-2	
		lb-ft-s ²		3.10E-2		3.90E-2	
Weight (KBMS)	Wt	Kg		27.9		39.8	
		lb		61.4		87.7	
Max Static Friction	Tf	Nm		2.71		4.07	
		lb-ft		2.00		3.00	
Cogging Friction (peak-to-peak)	Tcog	Nm		2.03		3.05	
		lb-ft		1.50		2.25	
Viscous Damping	Fi	Nm/ kRPM		0.461		0.691	
		lb-ft / kRPM		0.340		0.510	
Thermal Resistance (4)	TPR	°C / watt		0.236		0.192	
Number of Poles	P	-		38		38	
Recommended Kollmorgen AKD Drive				02407	02407	02407	04807
Voltage Req'd at Rated Output	Vac Input	Vac		480	400	480	400
Peak Stall Torque (4) (Motor with Drive)	Tp Drive	Nm	+/-10%	249	214	316	393
		lb-ft		184	158	233	290
Cont. Stall Torque (4) (Motor with Drive)	Tc Drive	Nm	+/-10%	108	108	154	154
		lb-ft		79.7	79.7	114	114

- Notes 1) Winding temperature = 155°C at continuous stall, at rated output, and for performance curves.
2) To calculate no-load Kt and Kb at 25°C, multiply by 1.064.
3) TPR assumes motor is housed and mounted to a 12" x 12" x 3/4" heat sink or equivalent.
4) Peak & Continuous Torques may be limited by drive current, see www.kollmorgen.com for complete drive ratings.

KBM 60 Performance Curves

Continuous duty capability for 130°C rise in a 25°C ambient using recommended AKD servo drive and sinusoidal commutation.

**KBM(S)-60X00
Continuous Torque**

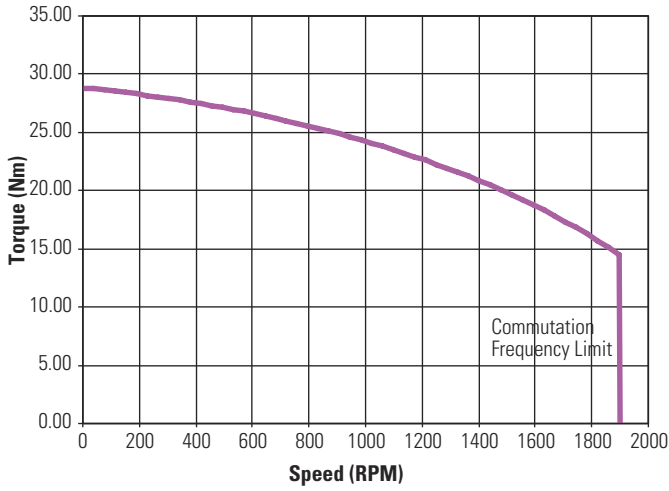

— A Winding-480 Vac / B Winding-400 Vac / C Winding-240 Vac

**KBM(S)-60X01
Continuous Torque**

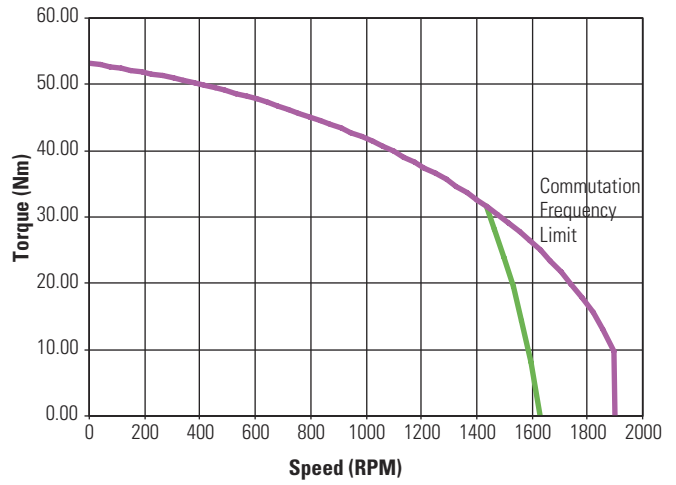

— A Winding-480 Vac / B Winding-400 Vac — C Winding-240 Vac

**KBM(S)-60X02
Continuous Torque**

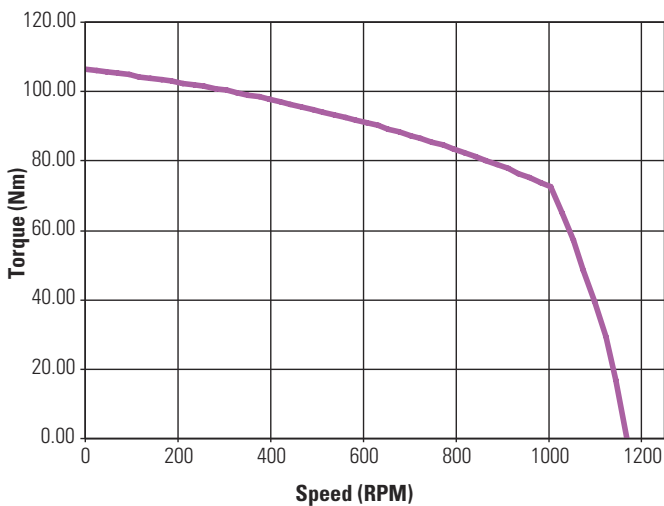

— A Winding-480 Vac / B Winding-400 Vac

**KBM(S)-60X03
Continuous Torque**

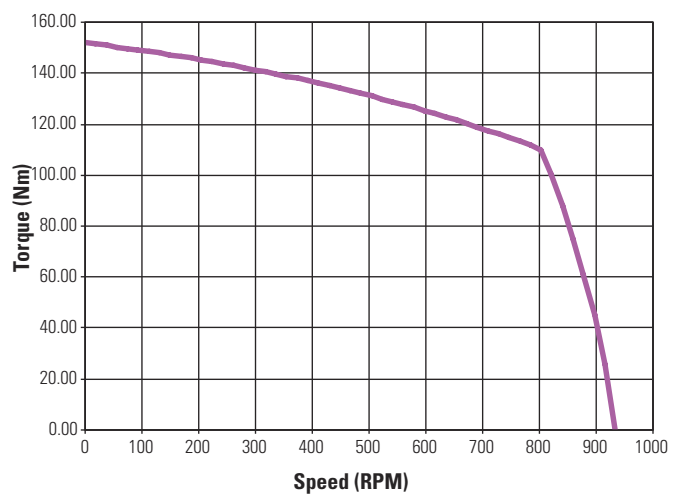

— A Winding-480 Vac / B Winding-400 Vac

Low Voltage optimized windings available.

Notes

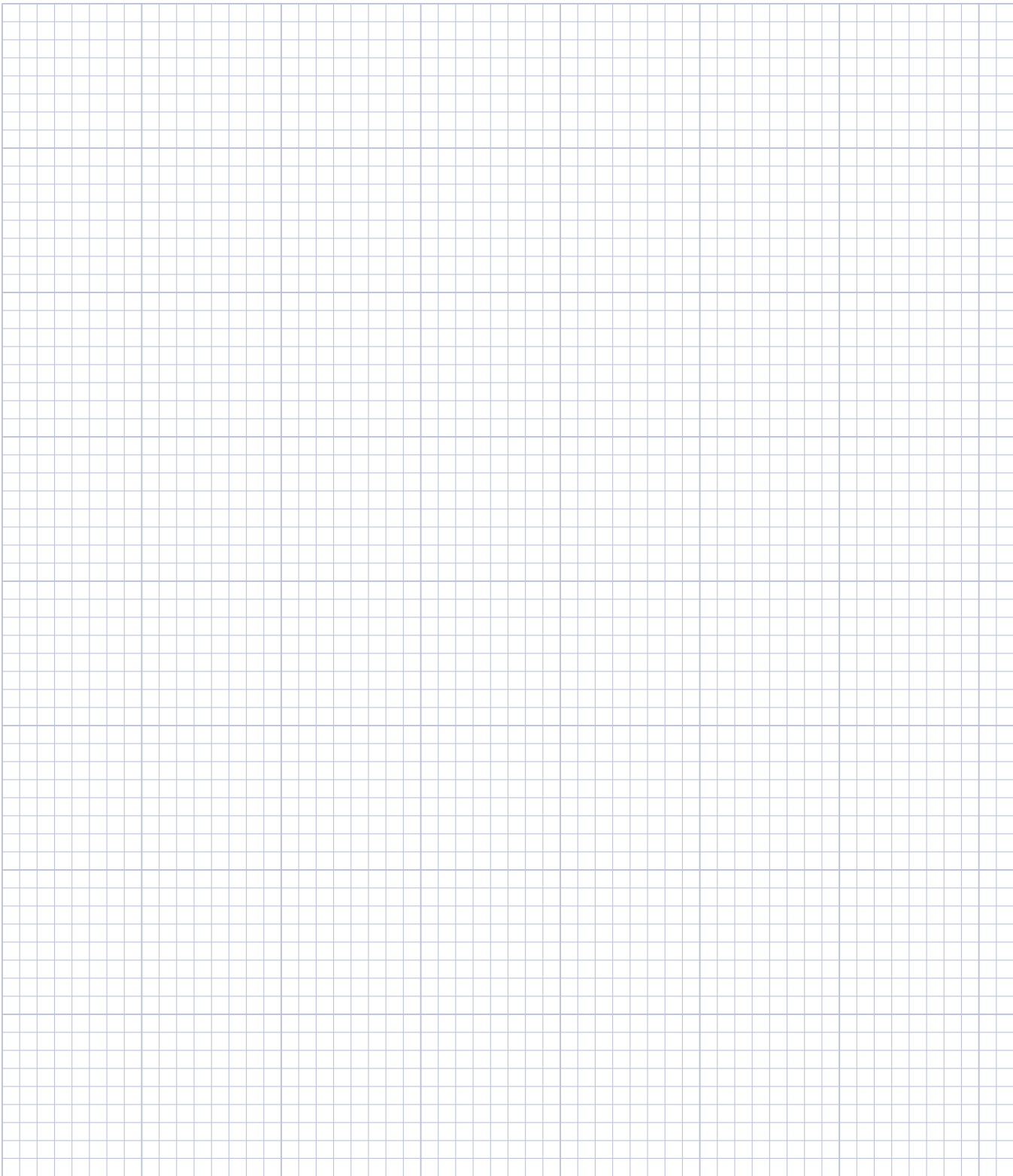

KBM 79 Frameless Motors

K B M 7 9

The KBM(S)-79 series provides a classic torque motor footprint - large diameter with a short axial length. With a skewed stator, low cogging, and low harmonic distortion these motors produce extremely smooth rotation. In addition, the high pole count and excellent torque / volume ratio makes the KBM(S)-79 an ideal fit for direct drive applications requiring high torque at low to moderate speeds.

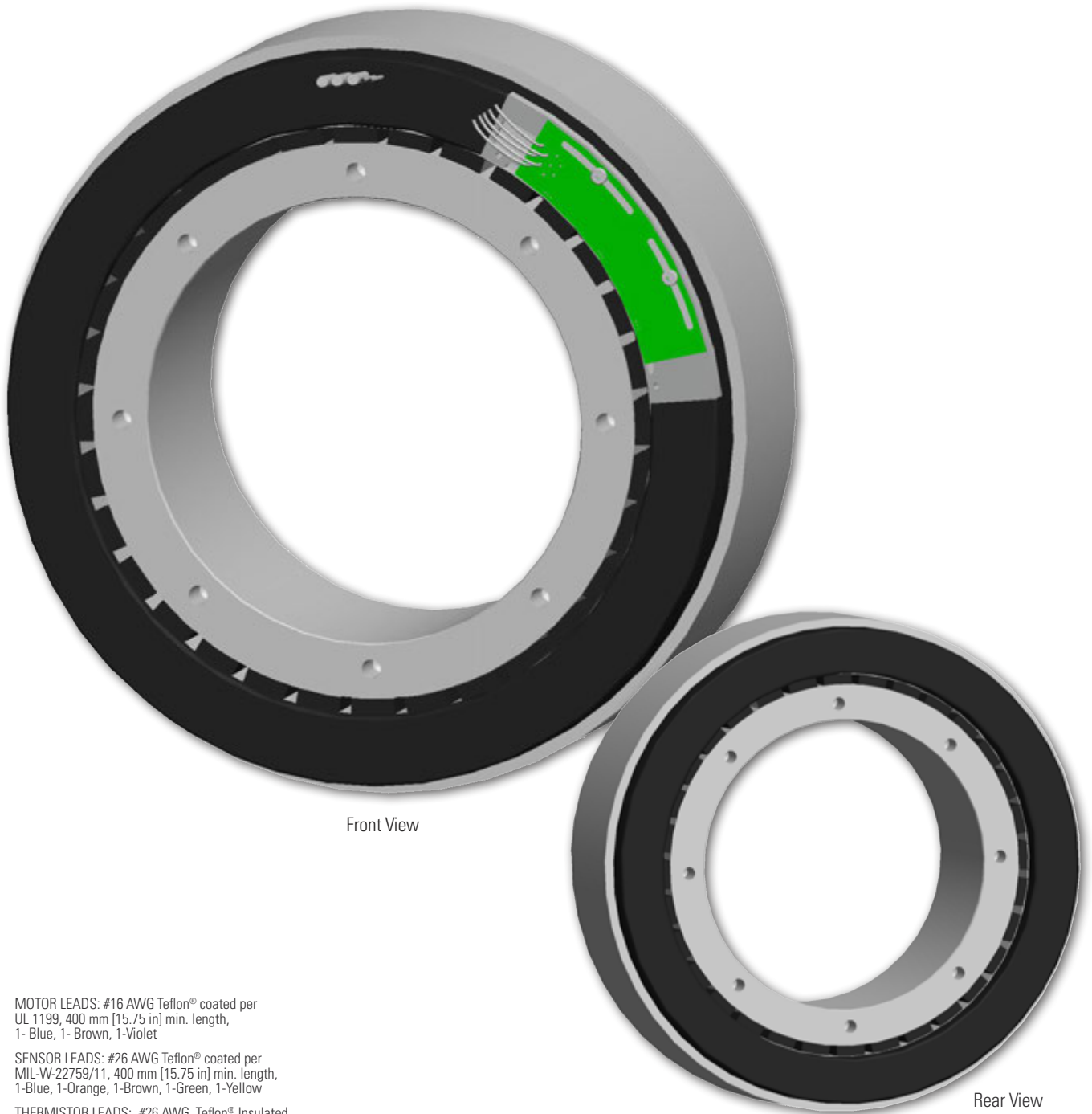

MOTOR LEADS: #16 AWG Teflon® coated per UL 1199, 400 mm [15.75 in] min. length, 1- Blue, 1- Brown, 1- Violet

SENSOR LEADS: #26 AWG Teflon® coated per MIL-W-22759/11, 400 mm [15.75 in] min. length, 1-Blue, 1-Orange, 1-Brown, 1-Green, 1-Yellow

THERMISTOR LEADS: #26 AWG, Teflon® Insulated, 400 mm [15.75"] min. length, 1-Blue, 1-Red

KBM 79 Outline Drawings

KBM 79

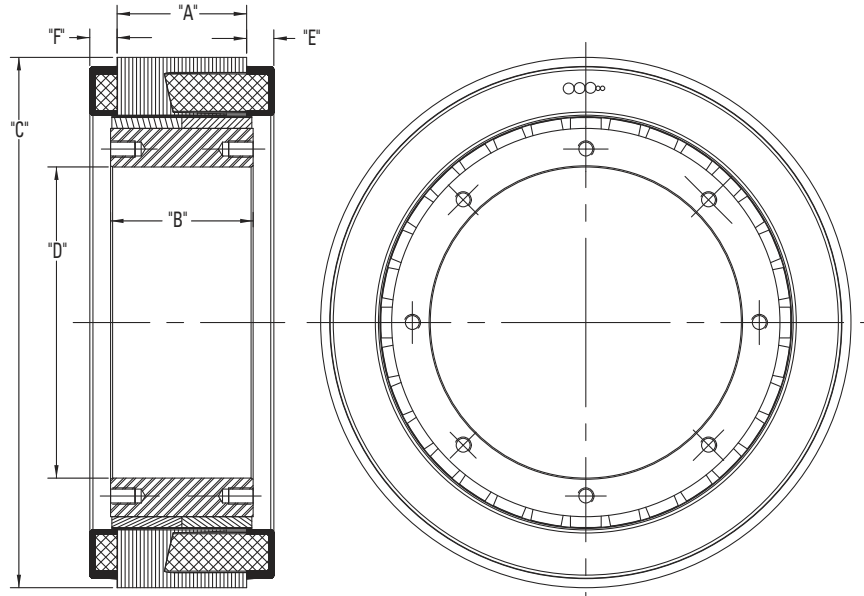

Model Number	"A" mm[inch]	"B" mm[inch]	∅ "C" mm[inch]	∅ "D" mm[inch]	"E" MAX mm[inch]	"F" MAX mm[inch]
KBM-79X01	31.75 [1.250]	38.10 [1.500]	259.63 [10.221]	152.43 [6.001]	13.34 [.525]	13.34 [.525]
KBM-79X02	63.50 [2.500]	69.85 [2.750]				
KBM-79X03	127.00 [5.000]	133.35 [5.250]				
KBM-79X04	170.94 [6.730]	177.29 [6.980]				
KBM-79X05	214.89 [5.000]	221.49 [8.720]				

All dimensions are nominal. For more detailed and interactive 3D models with 2D product views, visit www.kollmorgen.com/kbm

KBMS 79

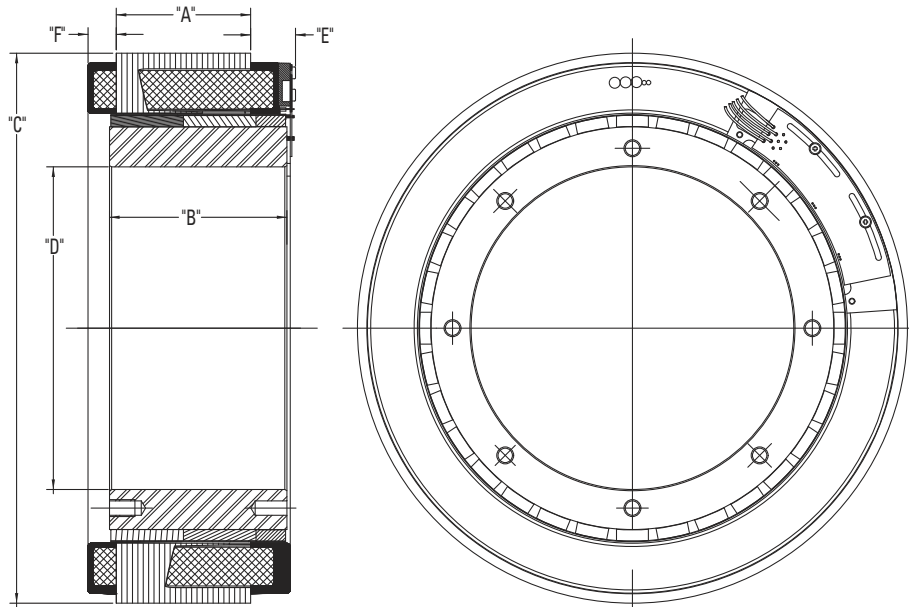

Model Number	"A" mm[inch]	"B" mm[inch]	∅ "C" mm[inch]	∅ "D" mm[inch]	"E" MAX mm[inch]	"F" MAX mm[inch]
KBMS-79X01	31.75 [1.250]	52.07 [2.050]	259.63 [10.221]	152.43 [6.001]	21.20 [.835]	13.34 [.525]
KBMS-79X02	63.50 [2.500]	83.82 [3.300]				
KBMS-79X03	127.00 [5.000]	147.07 [5.790]				
KBMS-79X04	170.94 [6.730]	191.26 [7.530]				
KBMS-79X05	214.89 [5.000]	235.46 [9.270]				

All dimensions are nominal. For more detailed and interactive 3D models with 2D product views, visit www.kollmorgen.com/kbm

KBM 79 Performance Data

KBM(S)-79XXX PERFORMANCE DATA & MOTOR PARAMETERS												
Motor Parameter	Symbol	Units	TOL	KBM(S)-79X01-X			KBM(S)-79X02-X			KBM(S)-79X03-X		
				A	B	C	A	B	C	A	B	C
Continuous Stall Torque at 25°C Amb. (1)	Tc	Nm	NOM	43.5	43.5	43.5	79.6	79.6	79.6	143	143	143
		lb-ft		32.1	32.1	32.1	58.7	58.7	58.7	106	106	106
Continuous Current	Ic	Arms	NOM	4.95	6.00	10.0	5.40	6.50	11.0	6.76	8.00	13.2
Peak Stall Torque (25°C winding temp)	Tp	Nm	NOM	152	152	152	319	319	319	637	637	637
		lb-ft		112	112	112	235	235	235	470	470	470
Peak Current	Ip	Arms	NOM	20.8	25.3	41.7	26.1	31.4	52.4	36.7	46.3	73.7
Rated Continuous Output Power at 25°C Amb. (1)	P Rated	Watts		2585	2585	2585	2920	2920	2920	3750	3750	3640
	HP Rated	HP		3.47	3.47	3.47	3.91	3.91	3.91	5.03	5.03	4.88
Speed at Rated Power	N Rated	RPM		730	730	730	430	430	430	300	300	290
Torque Sensitivity (2)	Kt	Nm / Arms	+/-10%	8.87	7.34	4.43	14.9	12.4	7.46	21.4	18.1	11.0
		lb-ft / Arms		6.54	5.42	3.27	11.0	9.17	5.50	15.8	13.4	8.10
Back EMF Constant	Kb	Vrms/kRPM	+/- 10%	536	444	268	902	751	450	1295	1096	664
Motor Constant	Km	Nm/√watt	+/-10%	2.89	2.89	2.89	4.81	4.81	4.81	7.29	7.29	7.29
		lb-ft/√watt		2.13	2.13	2.13	3.55	3.55	3.55	5.38	5.38	5.38
Resistance (line to line)	Rm	Ohms	+/- 10%	6.26	4.25	1.56	6.40	4.44	1.60	5.75	3.86	1.47
Inductance	Lm	mH		23	16	5.8	32	22	8.0	34	24	8.9
Inertia (KBM)	Jm	Kg-m ²		3.25E-2			5.97E-2			0.114		
		lb-ft-s ²		2.40E-2			4.40E-2			8.40E-2		
Weight (KBM)	Wt	Kg		9.21			16.9			32.1		
		lb		20.3			37.3			70.8		
Inertia (KBMS)	Jm	Kg-m ²		4.45E-2			7.15E-2			0.125		
		lb-ft-s ²		3.28E-2			5.27E-2			9.20E-2		
Weight (KBMS)	Wt	Kg		10.7			18.40			33.5		
		lb		23.5			40.5			73.9		
Max Static Friction	Tf	Nm		0.407			0.746			1.36		
		lb-ft		0.300			0.550			1.00		
Cogging Friction (peak-to-peak)	Tcog	Nm		0.136			0.244			0.447		
		lb-ft		0.100			0.180			0.330		
Viscous Damping	Fi	Nm/kRPM		2.44			15.5			31.2		
		lb-ft /kRPM		1.80			11.4			23.0		
Thermal Resistance (3)	TPR	°C / watt		0.377			0.311			0.220		
Number of Poles	P	-		32			32			32		
Recommended Kollmorgen AKD Drive				00607	01207	02406	00607	01207	02406	01207	01207	02406
Voltage Req'd at Rated Output	Vac Input	Vac		480	400	240	480	400	240	480	400	240
Peak Stall Torque 4) (Motor with Drive)	Tp Drive	Nm		133	152	152	234	308	298	557	482	465
		lb-ft		98.1	112	112	173	227	220	411	356	343
Cont. Stall Torque 4) (Motor with Drive)	Tc Drive	Nm		43.5	43.5	43.5	79.6	79.6	79.6	143	143	143
		lb-ft		32.1	112	112	59	228	218	105	105	105

- Notes
- 1) Winding temperature = 155°C at continuous stall, at rated output, and for performance curves.
 - 2) To calculate no-load Kt and Kb at 25°C, multiply by 1.064.
 - 3) TPR assumes motor is housed and mounted to a 12" x 12" x 3/4" heat sink or equivalent.
 - 4) Peak & Continuous Torques may be limited by drive current, see www.kollmorgen.com for complete drive ratings.

KBM(S)-79XXX PERFORMANCE DATA & MOTOR PARAMETERS									
Motor Parameter	Symbol	Units	TOL	KBM(S)-79X04-X			KBM(S)-79X05-X		
				A	B	C	A	B	C
Continuous Stall Torque at 25°C Amb. (1)	Tc	Nm	NOM	180	180	180	222	222	222
		lb-ft		133	133	133	163	163	163
Continuous Current	Ic	Arms	NOM	6.60	7.80	12.8	6.30	7.50	12.1
Peak Stall Torque (25°C winding temp)	Tp	Nm	NOM	858	858	858	1075	1075	1075
		lb-ft		633	633	633	793	793	793
Peak Current	Ip	Arms	NOM	36.7	46.3	73.7	36.7	46.3	73.7
Rated Continuous Output Power at 25°C Amb. (1)	P Rated	Watts		3540	3540	3540	3330	3330	3330
	HP Rated	HP		4.75	4.75	4.75	4.46	4.46	4.46
Speed at Rated Power	N Rated	RPM		215	215	215	165	165	165
Torque Sensitivity (2)	Kt	Nm / Arms	+/-10%	28.9	24.4	14.8	36.3	30.7	18.6
		lb-ft / Arms		21.3	18.0	10.9	26.7	22.6	13.7
Back EMF Constant	Kb	Vrms/kRPM	+/- 10%	1747	1478	896	2192	1856	1124
Motor Constant	Km	Nm/√watt	+/-10%	8.71	8.71	8.71	9.89	9.89	9.89
		lb-ft/√watt		6.42	6.42	6.42	7.30	7.30	7.30
Resistance (line to line)	Rm	Ohms	+/- 10%	7.34	5.20	1.88	8.96	6.02	2.30
Inductance	Lm	mH		46	33	12	57	41	15
Inertia (KBM)	Jm	Kg-m ²		0.152			0.191		
		lb-ft-s ²		0.112			0.141		
Weight (KBM)	Wt	Kg		44.0			54.9		
		lb		97.0			121		
Inertia (KBMS)	Jm	Kg-m ²		0.164			0.202		
		lb-ft-s ²		0.121			0.149		
Weight (KBMS)	Wt	Kg		45.3			56.2		
		lb		99.8			124.0		
Max Static Friction	Tf	Nm		1.83			2.29		
		lb-ft		1.35			1.69		
Cogging Friction (peak-to-peak)	Tcog	Nm		0.61			0.759		
		lb-ft		0.45			0.560		
Viscous Damping	Fi	Nm/kRPM		22.0			19.0		
		lb-ft /kRPM		16.0			26.0		
Thermal Resistance (3)	TPR	°C / watt		0.19			0.169		
Number of Poles	P	-		32			32		
Recommended Kollmorgen AKD Drive				01207	01207	02406	01207	01207	02406
Voltage Req'd at Rated Output	Vac Input	Vac		480	400	240	480	400	240
Peak Stall Torque (4) (Motor with Drive)	Tp Drive	Nm		751	650	627	941	817	787
		lb-ft		554	479	462	694	603	580
Cont. Stall Torque (4) (Motor with Drive)	Tc Drive	Nm		180	180	180	222	222	222
		lb-ft		133	133	133	164	164	164

- Notes
- 1) Winding temperature = 155°C at continuous stall, at rated output, and for performance curves.
 - 2) To calculate no-load Kt and Kb at 25°C, multiply by 1.064.
 - 3) TPR assumes motor is housed and mounted to a 12" x 12" x 3/4" heat sink or equivalent.
 - 4) Peak & Continuous Torques may be limited by drive current, see www.kollmorgen.com for complete drive ratings.

KBM 79 Performance Curves

Continuous duty capability for 130°C rise in a 25°C ambient using recommended AKD servo drive and sinusoidal commutation.

**KBM(S)-79X01
ContinuousTorque**

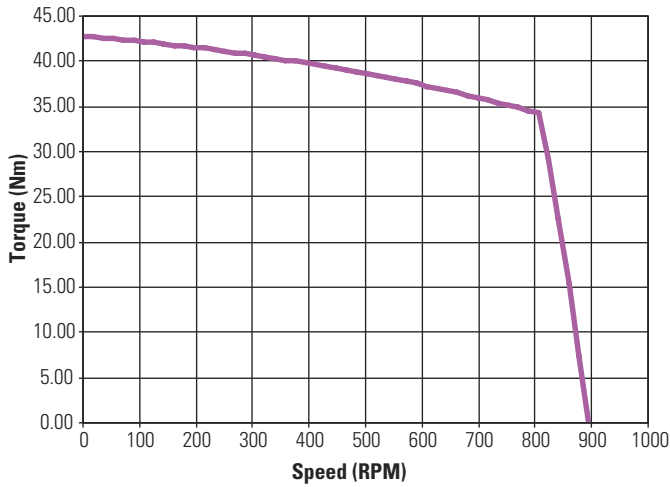

— A Winding-480 Vac / B Winding-400 Vac / C Winding-240 Vac

**KBM(S)-79X02
ContinuousTorque**

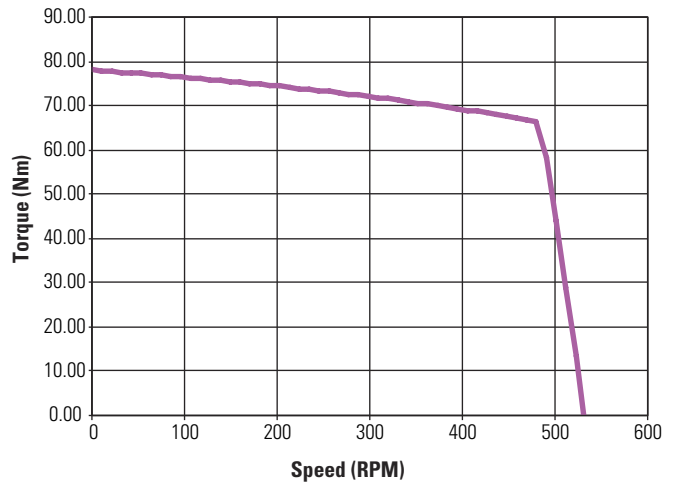

— A Winding-480 VAC / B Winding-400 VAC / C Winding-240 VAC

**KBM(S)-79X03
ContinuousTorque**

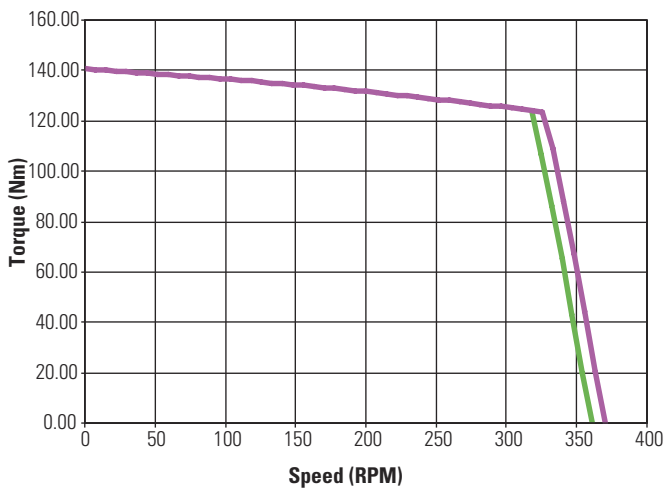

— A Winding-480 Vac — B Winding-400 Vac / C Winding-240 Vac

**KBM(S)-79X04
ContinuousTorque**

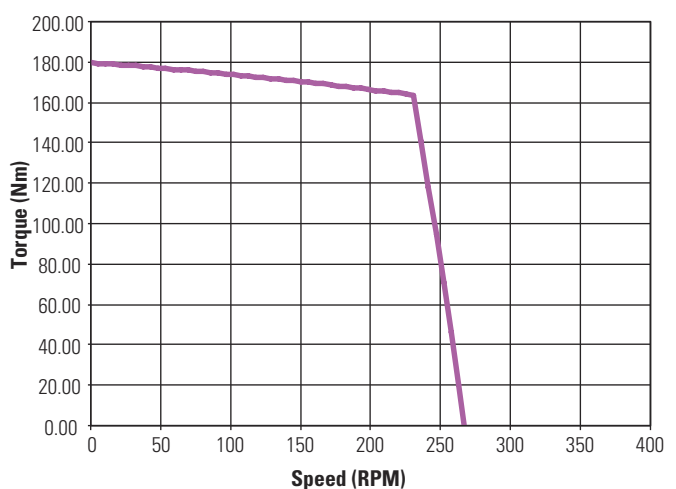

— A Winding-480 Vac / B Winding-400 Vac / C Winding-240 Vac

Low Voltage optimized windings available.

KBM 88 Frameless Motors

The KBM(S)-88 series has an optimized slot / pole combination offering extremely high continuous torque capability while still maintaining very low total harmonic distortion. The higher pole count and excellent torque / volume ratio makes the KBM(S)-88 an ideal fit for direct drive applications requiring high torque at low to moderate speeds.

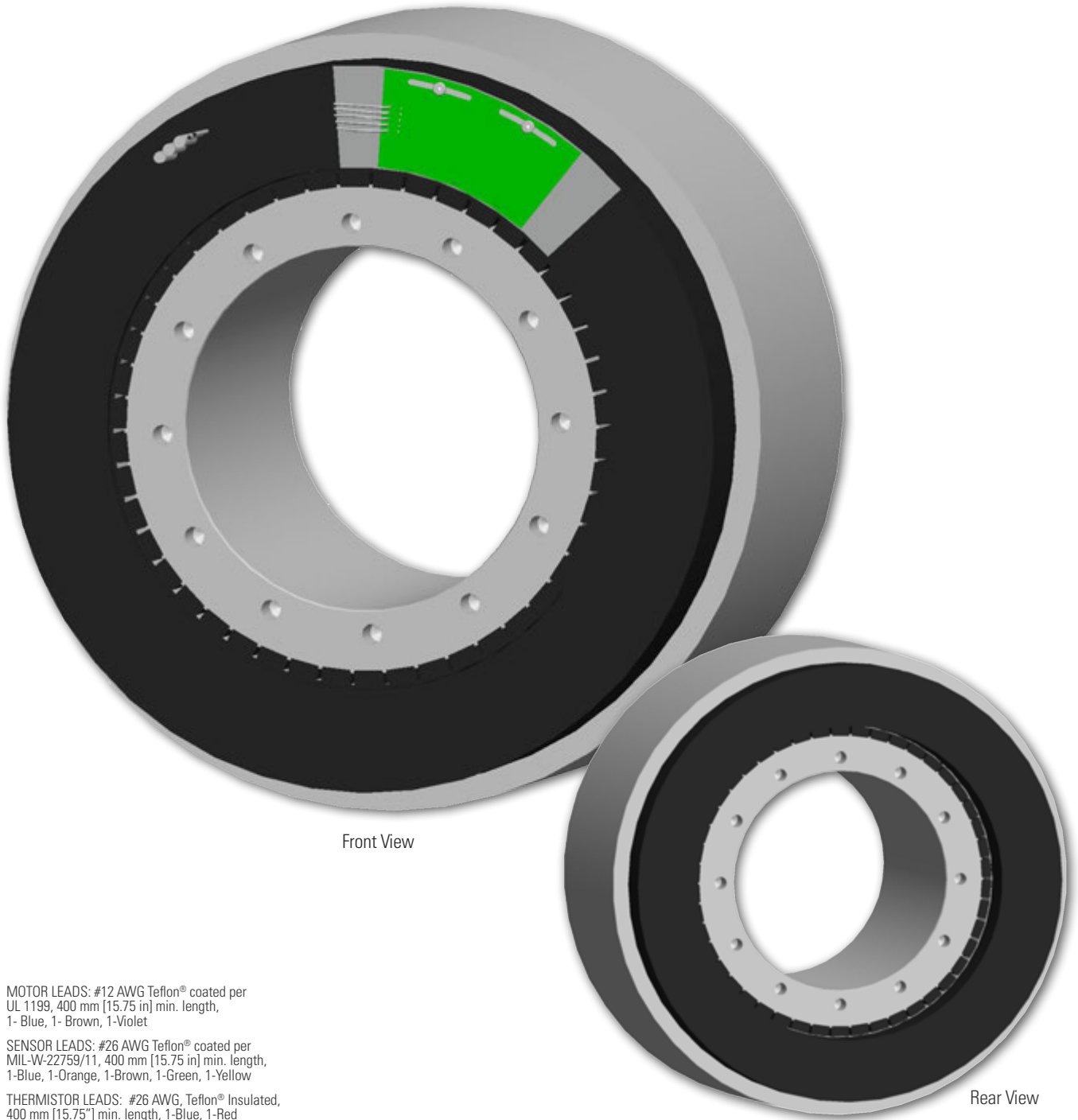

Front View

Rear View

MOTOR LEADS: #12 AWG Teflon® coated per UL 1199, 400 mm [15.75 in] min. length, 1-Blue, 1-Brown, 1-Violet

SENSOR LEADS: #26 AWG Teflon® coated per MIL-W-22759/11, 400 mm [15.75 in] min. length, 1-Blue, 1-Orange, 1-Brown, 1-Green, 1-Yellow

THERMISTOR LEADS: #26 AWG, Teflon® Insulated, 400 mm [15.75"] min. length, 1-Blue, 1-Red

KBM 88 Outline Drawings

KBM 88

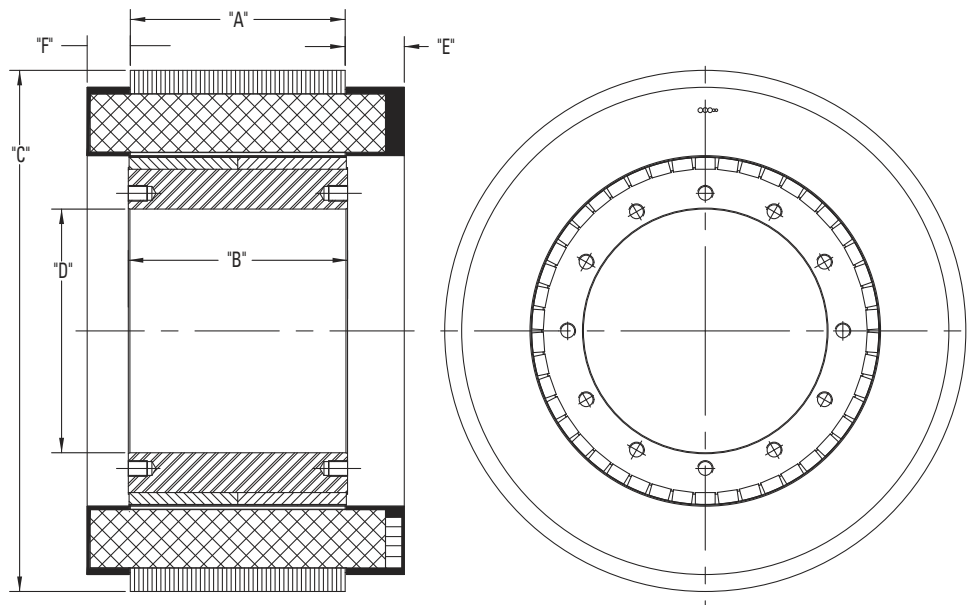

Model Number	"A" mm[inch]	"B" mm[inch]	Ø "C" mm[inch]	Ø "D" mm[inch]	"E" MAX mm[inch]	"F" MAX mm[inch]
KBM-88X00	33.66 [1.325]	36.37 [1.432]	331.46 [13.049]	155.01 [6.103]	37.59 [1.480]	27.43 [1.080]
KBM-88X01	67.56 [2.660]	70.36 [2.770]				
KBM-88X02	136.65 [5.380]	139.44 [5.490]				
KBM-88X03	205.74 [8.100]	208.53 [8.210]				

All dimensions are nominal. For more detailed and interactive 3D models with 2D product views, visit www.kollmorgen.com/kbm

KBMS 88

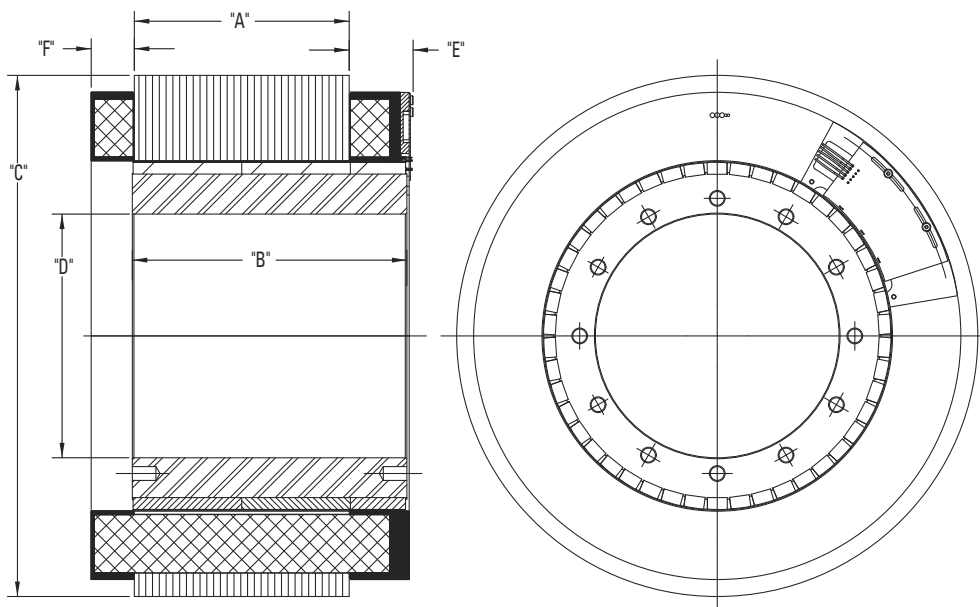

Model Number	"A" mm[inch]	"B" mm[inch]	Ø "C" mm[inch]	Ø "D" mm[inch]	"E" MAX mm[inch]	"F" MAX mm[inch]
KBMS-88X00	33.66 [1.325]	71.37 [2.810]	331.46 [13.049]	155.01 [6.103]	40.64 [1.600]	27.43 [1.080]
KBMS-88X01	67.56 [2.660]	105.41 [4.150]				
KBMS-88X02	136.65 [5.380]	174.63 [6.875]				
KBMS-88X03	205.74 [8.100]	243.84 [9.600]				

All dimensions are nominal. For more detailed and interactive 3D models with 2D product views, visit www.kollmorgen.com/kbm

KBM 88 Performance Data

KBM(S)-88XXX PERFORMANCE DATA & MOTOR PARAMETERS										
Motor Parameter	Symbol	Units	TOL	KBM(S)-88X00-X			KBM(S)-88X01-X			
				A	B	C	A	B	C	D
Continuous Stall Torque at 25°C Amb. (1)	Tc	Nm	NOM	102	102	102	205	209	205	207
		lb-ft		75.1	75.1	75.1	151	154	151	153
Continuous Current	Ic	Arms	NOM	17.0	20.5	34.0	17.1	32.1	7.50	40.2
Peak Stall Torque (25°C winding temp)	Tp	Nm	NOM	197	197	197	390	390	390	390
		lb-ft		145	145	145	288	288	288	288
Peak Current	Ip	Arms	NOM	40.0	48.3	80.2	40.0	75.4	17.8	94.7
Rated Continuous Output Power at 25°C Amb. (1)	P Rated	Watts		5460	5460	5460	8250	6600	3870	6600
	HP Rated	HP		7.32	7.32	7.32	11.1	8.85	5.19	8.85
Speed at Rated Power	N Rated	RPM		1000	1000	1000	520	940	205	940
Torque Sensitivity (2)	Kt	Nm / Arms	+/-10%	6.08	5.06	3.04	12.2	6.57	27.7	5.18
		lb-ft / Arms		4.48	3.74	2.24	9.00	4.85	20.5	3.82
Back EMF Constant	Kb	Vrms/kRPM	+/- 10%	368	306	184	738	397	1677	313
Motor Constant	Km	Nm/√watt	+/-10%	6.10	6.10	6.10	10.3	10.5	10.2	10.4
		lb-ft /√watt		4.50	4.50	4.50	7.62	7.75	7.60	7.70
Resistance (line to line)	Rm	Ohms	+/- 10%	0.660	0.460	0.165	0.930	0.261	4.90	0.164
Inductance	Lm	mH		6.5	4.5	1.6	13	3.7	67	2.3
Inertia (KBM)	Jm	Kg-m ²		5.26E-02			9.84E-2			
		lb-ft-s ²		3.88E-02			7.26E-2			
Weight (KBM)	Wt	Kg		15.7			37.6			
		lb		34.6			83.0			
Inertia (KBMS)	Jm	Kg-m ²		0.103			0.146			
		lb-ft-s ²		7.62E-02			0.108			
Weight (KBMS)	Wt	Kg		21.0			42.6			
		lb		46.4			94.0			
Max Static Friction	Tf	Nm		1.08			2.17			
		lb-ft		0.800			1.60			
Cogging Friction (Peak-to-Peak)	Tcog	Nm		0.810			1.63			
		lb-ft		0.600			1.20			
Viscous Damping	Fi	Nm/ kRPM		0.385			0.773			
		lb-ft / kRPM		0.284			0.570			
Thermal Resistance (3)	TPR	°C / watt		0.305			0.215			
Number of Poles	P	-		46			46			
Recommended Kollmorgen AKD Drive				02407	02407	04807	02407	04807	01207	04807
Voltage Req'd at Rated Output	Vac Input	Vac		480	400	240	480	480	480	400
Peak Stall Torque (4) (Motor with Drive)	Tp Drive	Nm	+/-10%	197	197	197	390	390	390	390
		lb-ft		145	145	145	288	288	288	288
Cont. Stall Torque (4) (Motor with Drive)	Tc Drive	Nm	+/-10%	102	102	102	205	209	205	207
		lb-ft		75.1	75.1	75.1	151	154	151	153

- Notes
- 1) Winding temperature = 155°C at continuous stall, at rated output, and for performance curves.
 - 2) To calculate no-load Kt and Kb at 25°C, multiply by 1.064.
 - 3) TPR assumes motor is housed and mounted to a 20" x 20" x 3/4" heat sink or equivalent.
 - 4) Peak & Continuous Torques may be limited by drive current, see www.kollmorgen.com for complete drive ratings.

KBM(S)-88XXX PERFORMANCE DATA & MOTOR PARAMETERS									
Motor Parameter	Symbol	Units	TOL	KBM(S)-88X02-X			KBM(S)-88X03-X		
				A	B	C	A	B	C
Continuous Stall Torque at 25°C Amb. (1)	Tc	Nm	NOM	385	385	385	538	545	545
		lb-ft		284	284	284	397	402	402
Continuous Current	Ic	Arms	NOM	15.1	32.1	37.9	18.2	35.5	45.2
Peak Stall Torque (25°C winding temp)	Tp	Nm	NOM	789	789	789	1200	1200	1200
		lb-ft		582	582	582	885	885	885
Peak Current	Ip	Arms	NOM	40.0	75.4	89.0	53.1	106	134
Rated Continuous Output Power at 25°C Amb. (1)	P Rated	Watts		7950	13430	13430	10450	16000	16000
	HP Rated	HP		10.7	18.0	18.0	14.0	21.4	21.4
Speed at Rated Power	N Rated	RPM		235	550	550	225	425	425
Torque Sensitivity (2)	Kt	Nm / Arms	+/-10%	25.7	12.1	10.3	30.0	15.5	12.8
		lb-ft / Arms		19.0	8.95	7.59	22.1	11.5	9.4
Back EMF Constant	Kb	Vrms/kRPM	+/- 10%	1556	734	622	1812	940	772
Motor Constant	Km	Nm/√watt	+/-10%	16.3	16.3	16.3	20.6	20.9	20.9
		lb-ft / √watt		12.0	12.0	12.0	15.2	15.4	15.4
Resistance (line to line)	Rm	Ohms	+/- 10%	1.66	0.369	0.262	1.41	0.370	0.250
Inductance	Lm	mH		29	6.4	4.6	26	7.0	4.7
Inertia (KBM)	Jm	Kg-m ²		0.198			0.298		
		lb-ft-s ²		0.146			0.220		
Weight (KBM)	Wt	Kg		72.6			106		
		lb		160			234		
Inertia (KBMS)	Jm	Kg-m ²		0.247			0.315		
		lb-ft-s ²		0.182			0.232		
Weight (KBMS)	Wt	Kg		77.6			111		
		lb		171			245		
Max Static Friction	Tf	Nm		4.34			6.51		
		lb-ft		3.20			4.80		
Cogging Friction (Peak-to-Peak)	Tcog	Nm		3.25			4.88		
		lb-ft		2.40			3.60		
Viscous Damping	Fi	Nm/ kRPM		1.53			2.30		
		lb-ft / kRPM		1.13			1.70		
Thermal Resistance (3)	TPR	°C / watt		0.152			0.124		
Number of Poles	P	-		46			46		
Recommended Kollmorgen AKD Drive				02407	04807	04807	02407	04807	04807
Voltage Req'd at Rated Output	Vac Input	Vac		480	480	400	480	480	400
Peak Stall Torque (4) (Motor with Drive)	Tp Drive	Nm	+/-10%	789	789	789	1153	1160	1050
		lb-ft		582	582	582	850	856	774
Cont. Stall Torque (4) (Motor with Drive)	Tc Drive	Nm	+/-10%	385	385	385	538	545	545
		lb-ft		284	284	284	397	402	402

- Notes
- 1) Winding temperature = 155°C at continuous stall, at rated output, and for performance curves.
 - 2) To calculate no-load Kt and Kb at 25°C, multiply by 1.064.
 - 3) TPR assumes motor is housed and mounted to a 20" x 20" x 3/4" heat sink or equivalent.
 - 4) Peak & Continuous Torques may be limited by drive current, see www.kollmorgen.com for complete drive ratings.

KBM 88 Performance Curves

Continuous duty capability for 130°C rise in a 25°C ambient using recommended AKD servo drive and sinusoidal commutation.

**KBM(S)-88X00
Continuous Torque**

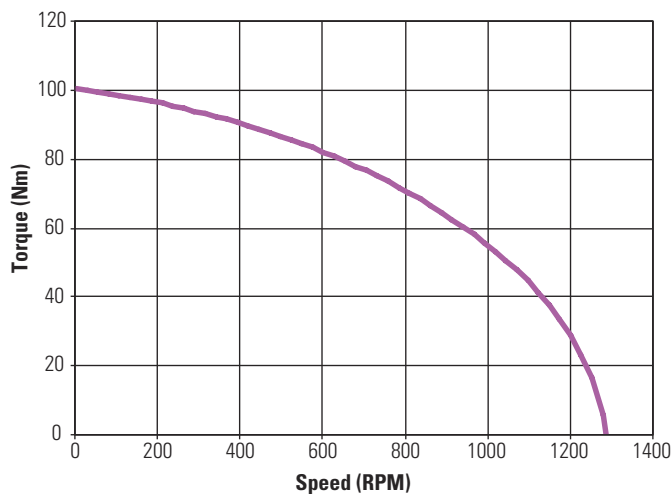

— A Winding-480 Vac / B Winding-400 Vac / C Winding-240 Vac

**KBM(S)-88X01
Continuous Torque**

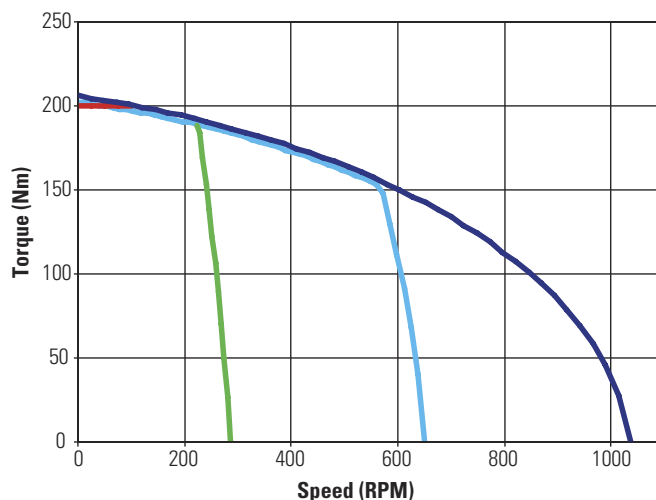

— A Winding-480 Vac — B Winding-480 Vac — C Winding-480 Vac
— D Winding-400 Vac

**KBM(S)-88X02
Continuous Torque**

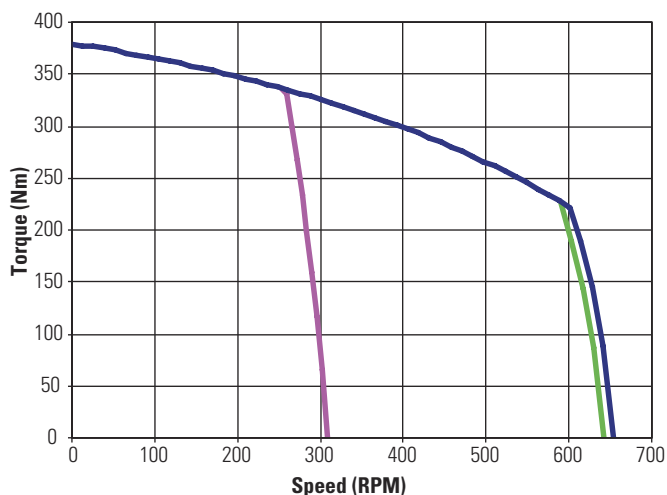

— A Winding-400 Vac — B Winding-480 Vac — C Winding-400 Vac

**KBM(S)-88X03
Continuous Torque**

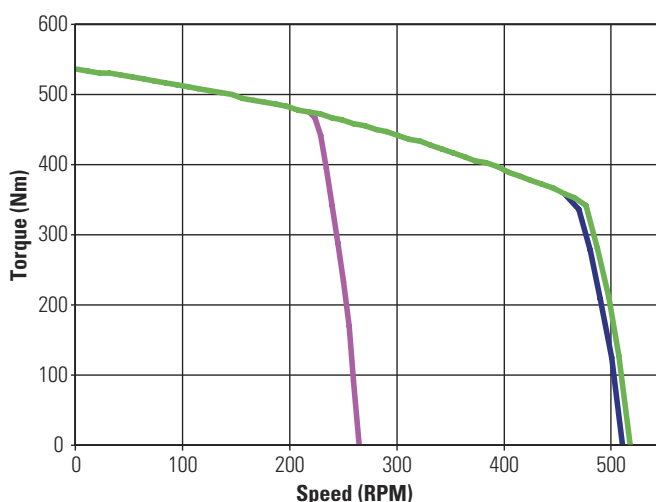

— A Winding-480 Vac — B Winding-480 Vac — C Winding-400 Vac

Low Voltage optimized windings available.

Notes

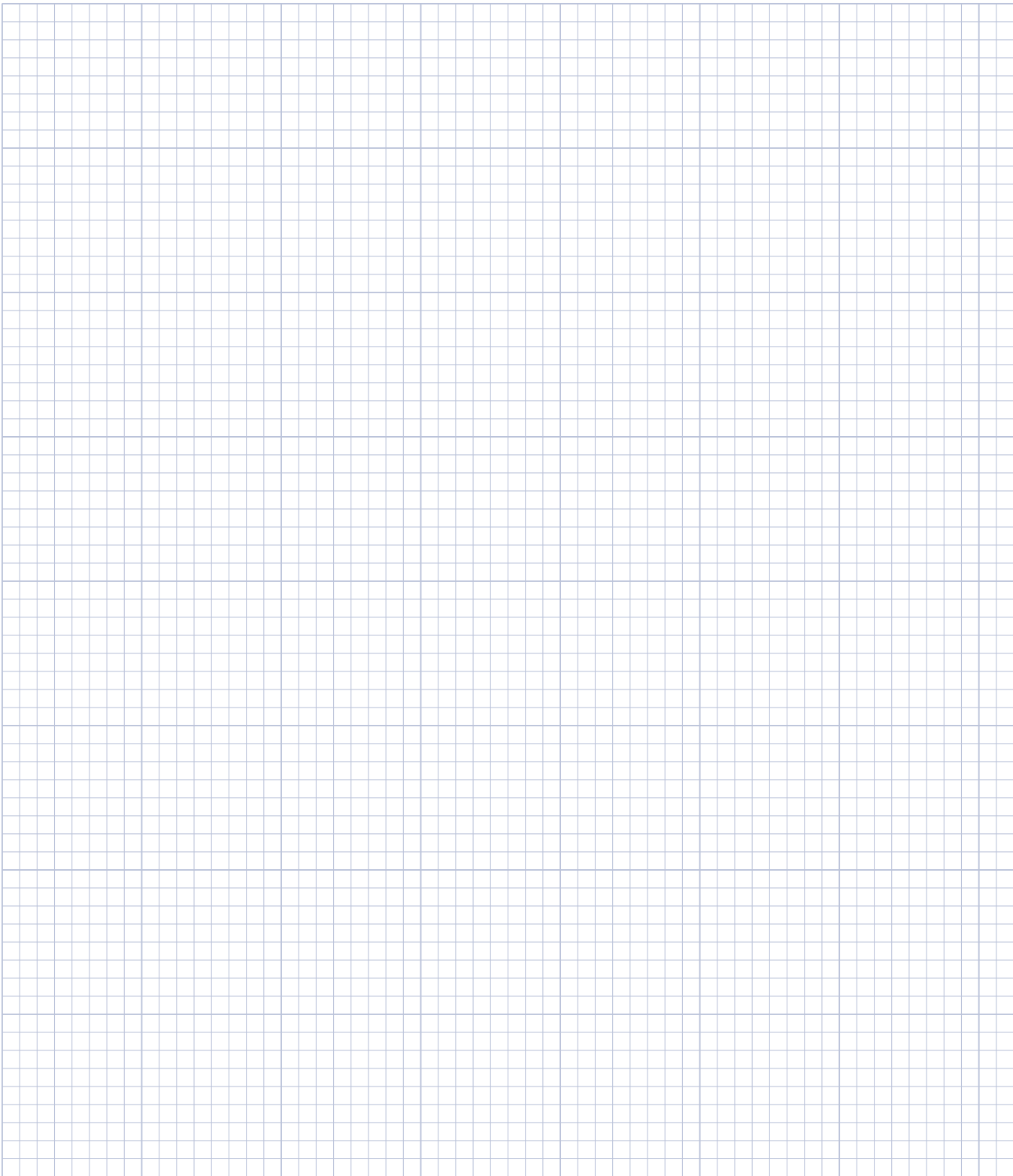
A large grid of graph paper for taking notes, consisting of 20 columns and 30 rows of small squares.

KBM 118 Frameless Motors

K B M 1 1 8

The KBM(S)-118 series provides a classic torque motor footprint - large diameter with a short axial length. With a skewed stator, low cogging, and low harmonic distortion these motors produce extremely smooth rotation. In addition, the high pole count and excellent torque / volume ratio makes the KBM(S)-118 an ideal fit for direct drive applications requiring high torque at low to moderate speeds.

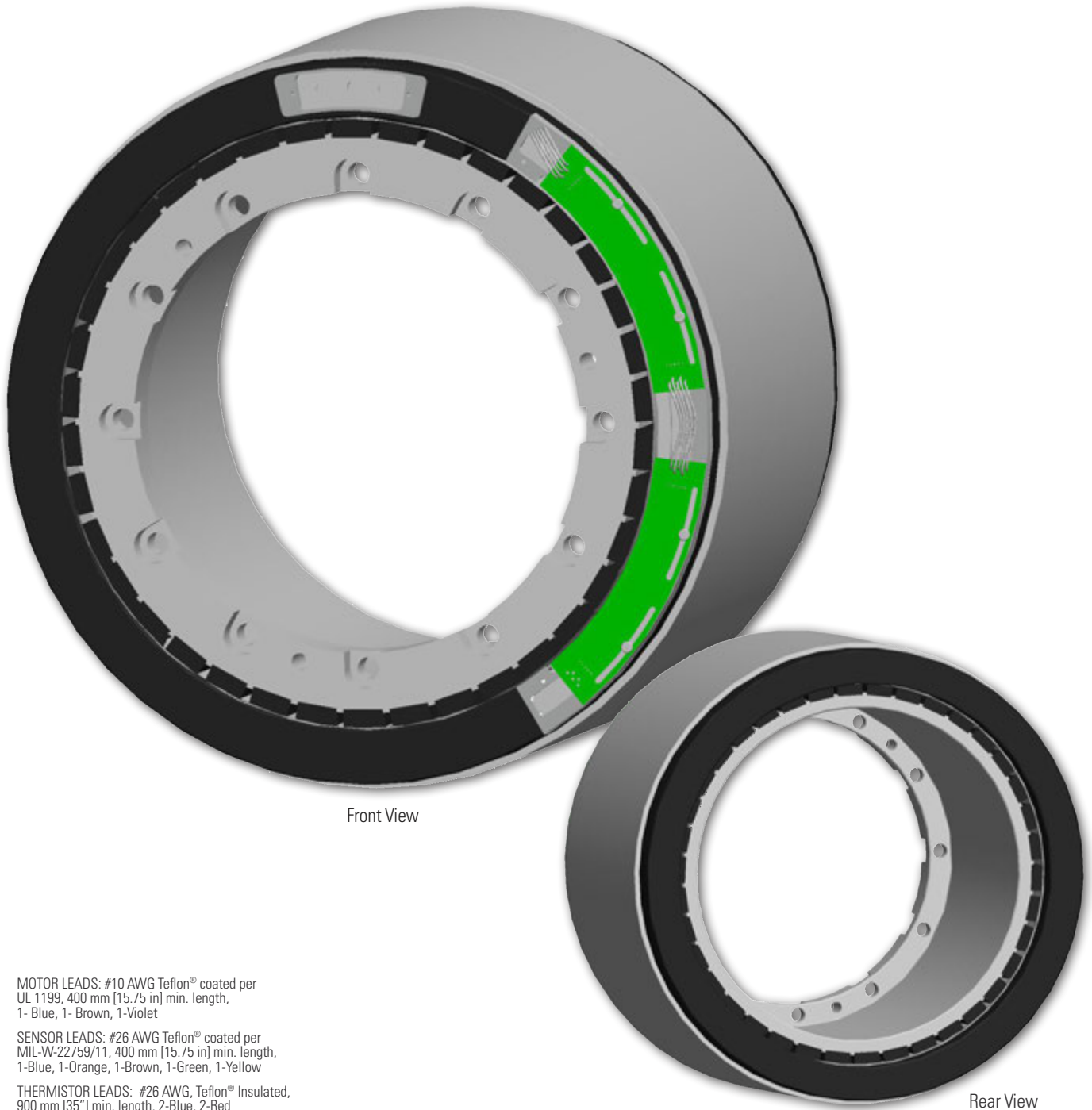

MOTOR LEADS: #10 AWG Teflon® coated per UL 1199, 400 mm [15.75 in] min. length, 1-Blue, 1-Brown, 1-Violet

SENSOR LEADS: #26 AWG Teflon® coated per MIL-W-22759/11, 400 mm [15.75 in] min. length, 1-Blue, 1-Orange, 1-Brown, 1-Green, 1-Yellow

THERMISTOR LEADS: #26 AWG, Teflon® Insulated, 900 mm [35"] min. length, 2-Blue, 2-Red

Rear View

KBM 118 Outline Drawings

KBM 118

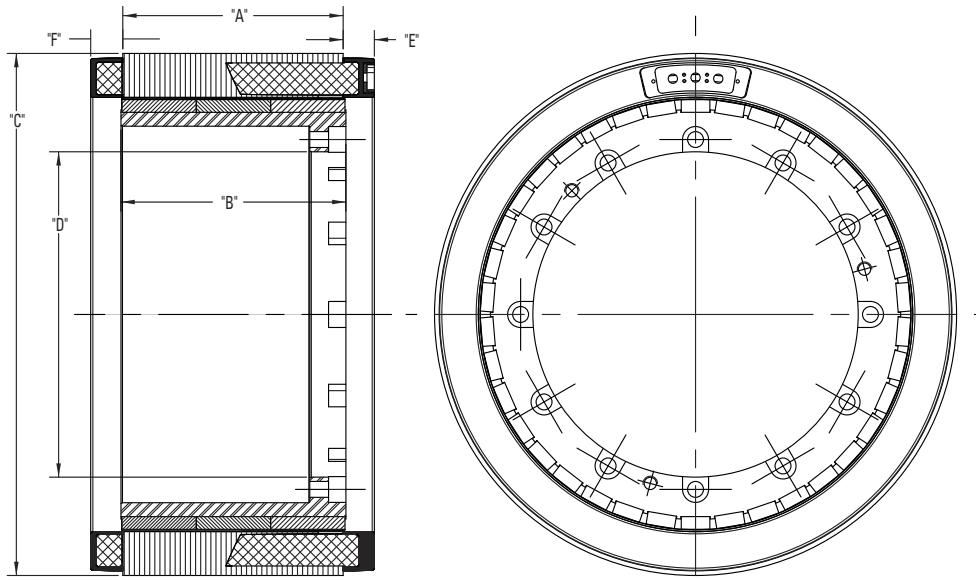

Model Number	"A" mm[inch]	"B" mm[inch]	Ø "C" mm[inch]	Ø "D" mm[inch]	"E" MAX mm[inch]	"F" MAX mm[inch]
KBM-118X00	50.80 [2.000]	50.71 [2.075]	361.11 [14.217]	225.04 [8.860]	21.59 [.850]	22.23 [.875]
KBM-118X01	101.60 [4.000]	104.14 [4.100]				
KBM-118X02	152.40 [6.000]	155.58 [6.125]				
KBM-118X03	203.20 [8.000]	207.26 [8.160]				
KBM-118X04	254.00 [10.000]	258.69 [10.185]				

All dimensions are nominal. For more detailed and interactive 3D models with 2D product views, visit www.kollmorgen.com/kbm

KBMS 118

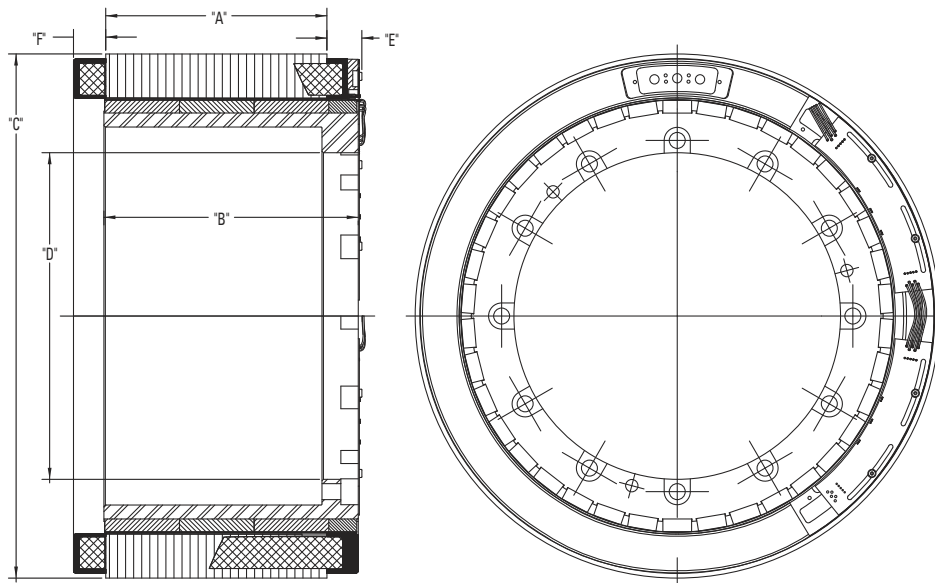

Model Number	"A" mm[inch]	"B" mm[inch]	Ø "C" mm[inch]	Ø "D" mm[inch]	"E" MAX mm[inch]	"F" MAX mm[inch]
KBMS-118X00	50.80 [2.000]	72.39 [2.850]	361.11 [14.217]	225.04 [8.860]	26.03 [1.025]	22.23 [.875]
KBMS-118X01	101.60 [4.000]	123.83 [4.875]				
KBMS-118X02	152.40 [6.000]	175.26 [6.900]				
KBMS-118X03	203.20 [8.000]	226.70 [8.925]				
KBMS-118X04	254.00 [10.000]	278.13 [10.950]				

All dimensions are nominal. For more detailed and interactive 3D models with 2D product views, visit www.kollmorgen.com/kbm

KBM 118 Performance Data

KBM(S)-118XXX PERFORMANCE DATA & MOTOR PARAMETERS											
Motor Parameter	Symbol	Units	TOL	KBM(S)-118X00-X			KBM(S)-118X01-X		KBM(S)-118X02-X		
				A	B	C	A	B	A	B	C
Continuous Stall Torque at 25°C Amb. (1)	Tc	Nm	NOM	172	172	172	325	325	446	446	446
		lb-ft		127	127	127	239	239	329	329	329
Continuous Current	Ic	Arms	NOM	21.6	27.0	40.2	43.7	76.5	47.0	57.0	94.5
Peak Stall Torque (25°C winding temp)	Tp	Nm	NOM	498	498	498	994	994	1451	1451	1255
		lb-ft		367	367	367	733	733	1070	1070	925
Peak Current	Ip	Arms	NOM	67.0	84.0	135	151	265	171	206	343
Rated Continuous Output Power at 25°C Amb. (1)	P Rated	Watts		7780	7780	7780	9000	9000	10350	10350	10350
	HP Rated	HP		10.4	10.4	10.4	12.1	12.1	13.9	13.9	13.9
Speed at Rated Power	N Rated	RPM		830	830	830	785	785	710	710	710
Torque Sensitivity (2)	Kt	Nm / Arms	+/-10%	8.24	6.59	4.40	7.58	4.33	9.66	8.05	4.83
		lb-ft / Arms		6.07	4.86	3.25	5.59	3.20	7.13	5.94	3.56
Back EMF Constant	Kb	Vrms/kRPM	+/- 10%	498	399	266	459	262	584	487	292
Motor Constant	Km	Nm/√watt	+/-10%	7.44	7.44	7.44	11.8	11.8	14.6	14.6	14.6
		lb-ft / √watt		5.49	5.49	5.49	8.70	8.70	10.8	10.8	10.8
Resistance (line to line)	Rm	Ohms	+/- 10%	0.817	0.518	0.228	0.276	0.088	0.292	0.191	0.073
Inductance	Lm	mH		5.7	3.7	1.6	2.5	0.82	2.7	1.9	0.70
Inertia (KBM)	Jm	Kg-m ²		0.129			0.267		0.396		
		lb-ft-s ²		0.095			0.197		0.292		
Weight (KBM)	Wt	Kg		18.9			37.1		53.5		
		lb		41.7			81.8		118		
Inertia (KBMS)	Jm	Kg-m ²		0.176			0.315		0.403		
		lb-ft-s ²		0.13			0.232		0.297		
Weight (KBMS)	Wt	Kg		21.2			39.2		56.2		
		lb		46.8			86.4		124		
Max Static Friction	Tf	Nm		3.2			6.39		9.57		
		lb-ft		2.36			4.71		7.06		
Cogging Friction (peak-to-peak)	Tcog	Nm		1.63			3.16		4.79		
		lb-ft		1.2			2.33		3.53		
Viscous Damping	Fi	Nm/ kRPM		14.5			38.8		59.7		
		lb-ft / kRPM		10.7			28.6		44.0		
Thermal Resistance (3)	TPR	°C / watt		0.156			0.110		0.089		
Number of Poles	P	-		38			38		38		
Recommended Kollmorgen AKD Drive				02407	04807	04807	04807		04807		
Recommended Kollmorgen S700 Drive								S772		S772	S772
Voltage Req'd at Rated Output	Vac Input	Vac		480	400	240	400	240	480	400	240
Peak Stall Torque (4) (Motor with Drive)	Tp Drive	Nm	+/-10%	357	498	380	677	558	846	1024	641
		lb-ft		263	367	280	499	412	624	755	473
Cont. Stall Torque (4) (Motor with Drive)	Tc Drive	Nm	+/-10%	172	172	172	325	300	446	446	331
		lb-ft		127	127	127	240	221	329	329	244

Notes 1) Winding temperature = 155°C at continuous stall, at rated output, and for performance curves.
 2) To calculate no-load Kt and Kb at 25°C, multiply by 1.064.
 3) TPR assumes the motor is housed and mounted to a heat sink.
 4) Peak torque may be limited by drive current, see www.kollmorgen.com for complete drive ratings.

KBM(S)-118XXX PERFORMANCE DATA & MOTOR PARAMETERS									
Motor Parameter	Symbol	Units	TOL	KBM(S)-118X03-X			KBM(S)-118X04-X		
				A	B	C	A	B	C
Continuous Stall Torque at 25°C Amb. (1)	Tc	Nm	NOM	560	560	560	672	672	672
		lb-ft		413	413	413	495	495	495
Continuous Current	Ic	Arms	NOM	44.0	54.0	89.5	42.8	51.5	86.0
Peak Stall Torque (25°C winding temp)	Tp	Nm	NOM	1932	1932	1661	2400	2400	2068
		lb-ft		1425	1425	1224	1770	1770	1524
Peak Current	Ip	Arms	NOM	171	206	343	171	206	343.0
Rated Continuous Output Power at 25°C Amb. (1)	P Rated	Watts		17000	17000	17000	19850	19850	19850
	HP Rated	HP		22.8	22.8	22.8	26.6	26.6	26.6
Speed at Rated Power	N Rated	RPM		535	535	535	420	420	420
Torque Sensitivity (2)	Kt	Nm / Arms	+/-10%	12.8	10.7	6.40	16.0	13.4	8.00
		lb-ft / Arms		9.46	7.88	4.72	11.8	9.8	5.90
Back EMF Constant	Kb	Vrms/kRPM	+/- 10%	775	646	387	969	808	484
Motor Constant	Km	Nm/√watt	+/-10%	17.1	17.1	17.1	19.4	19.4	19.4
		lb-ft / √watt		12.6	12.6	12.6	14.3	14.3	14.3
Resistance (line to line)	Rm	Ohms	+/- 10%	0.373	0.259	0.093	0.455	0.298	0.112
Inductance	Lm	mH		4.3	3.0	1.1	4.5	3.0	1.2
Inertia (KBM)	Jm	Kg-m ²		0.542			0.648		
		lb-ft-s ²		0.400			0.478		
Weight (KBM)	Wt	Kg		71.7			88.5		
		lb		158			195		
Inertia (KBMS)	Jm	Kg-m ²		0.591			0.698		
		lb-ft-s ²		0.436			0.515		
Weight (KBMS)	Wt	Kg		73.9			90.7		
		lb		163			200		
Max Static Friction	Tf	Nm		12.8			16.0		
		lb-ft		9.42			11.8		
Cogging Friction (peak-to-peak)	Tcog	Nm		6.39			8.13		
		lb-ft		4.71			6.00		
Viscous Damping	Fi	Nm/ kRPM		81.3			100		
		lb-ft / kRPM		60.0			74.0		
Thermal Resistance (3)	TPR	°C / watt		0.078			0.069		
Number of Poles	P	-		38			38		
Recommended Kollmorgen AKD Drive				04807			04807		
Recommended Kollmorgen S700 Drive					S772	S772		S772	S772
Voltage Req'd at Rated Output	Vac Input	Vac		480	400	240	480	400	240
Peak Stall Torque (4) (Motor with Drive)	Tp Drive	Nm	+/-10%	1122	1358	850	1402	1698	1062
		lb-ft		828	1002	627	1034	1252	783
Cont. Stall Torque (4) (Motor with Drive)	Tc Drive	Nm	+/-10%	560	560	438	678	678	547
		lb-ft		413	413	323	500	500	403

Notes 1) Winding temperature = 155°C at continuous stall, at rated output, and for performance curves.
2) To calculate no-load Kt and Kb at 25°C, multiply by 1.064.
3) TPR assumes the motor is housed and mounted to a heat sink.
4) Peak torque may be limited by drive current, see www.kollmorgen.com for complete drive ratings.

KBM 118 Performance Curves

Continuous duty capability for 130°C rise in a 25°C ambient using recommended AKD, or S700, servo drive and sinusoidal commutation.

**KBM(S)-118X00
Continuous Torque**

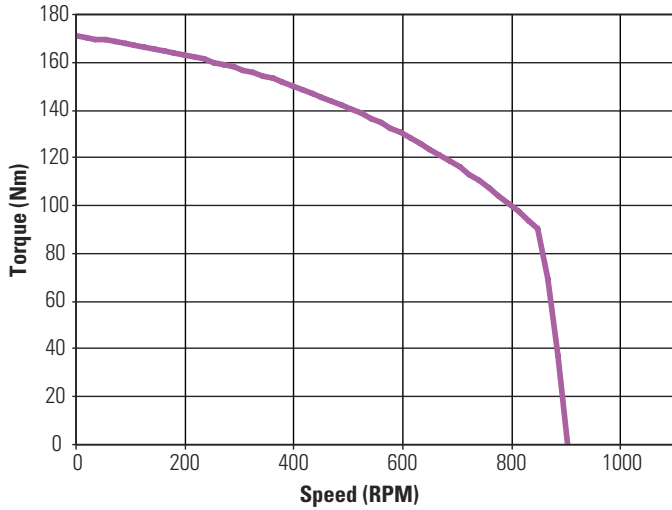

— A Winding-480 Vac / B Winding-400 Vac / C Winding-240 Vac

**KBM(S)-118X01
Continuous Torque**

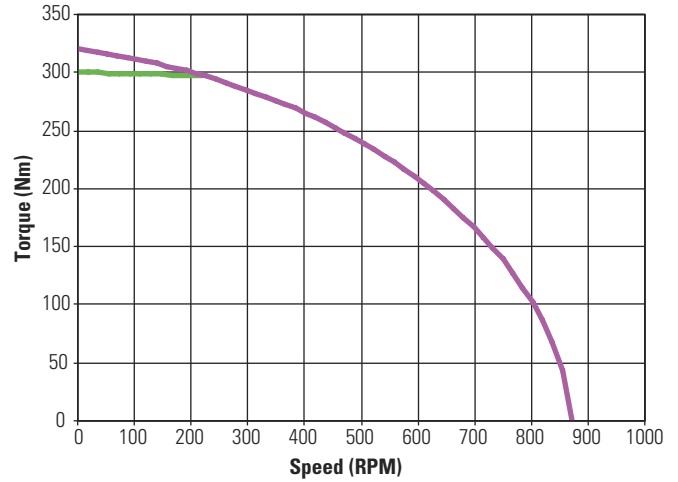

— A Winding-400 Vac — B Winding-240 Vac

**KBM(S)-118X02
Continuous Torque**

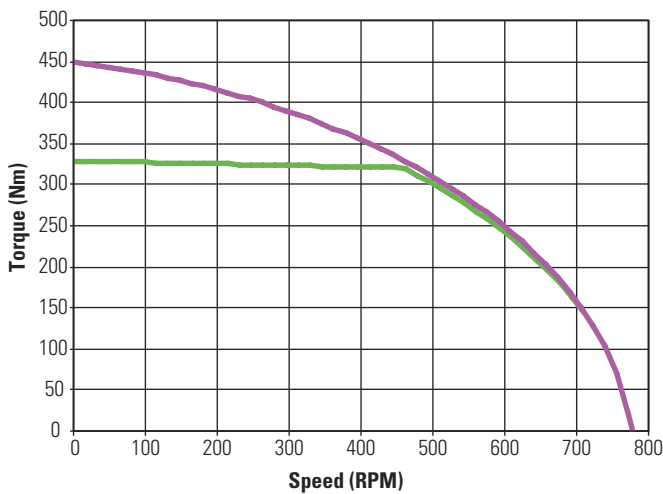

— A Winding-480 Vac / B Winding-400 Vac — C Winding-240 Vac

**KBM(S)-118X03
Continuous Torque**

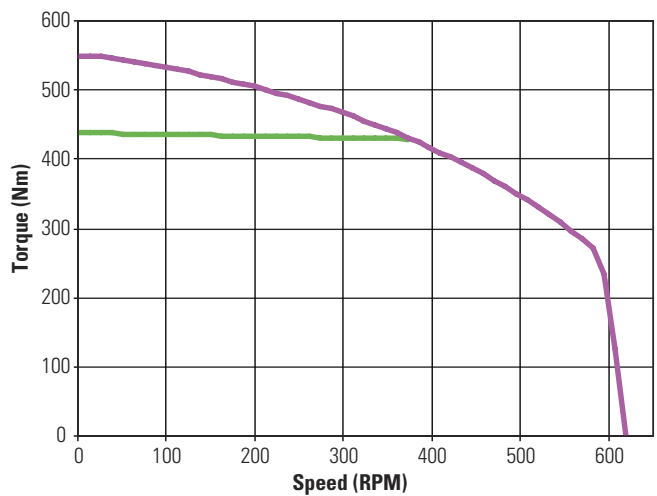

— A Winding-480 Vac / B Winding-400 Vac — C Winding-240 Vac

Low Voltage optimized windings available.

**KBM(S)-118X04
Continuous Torque**

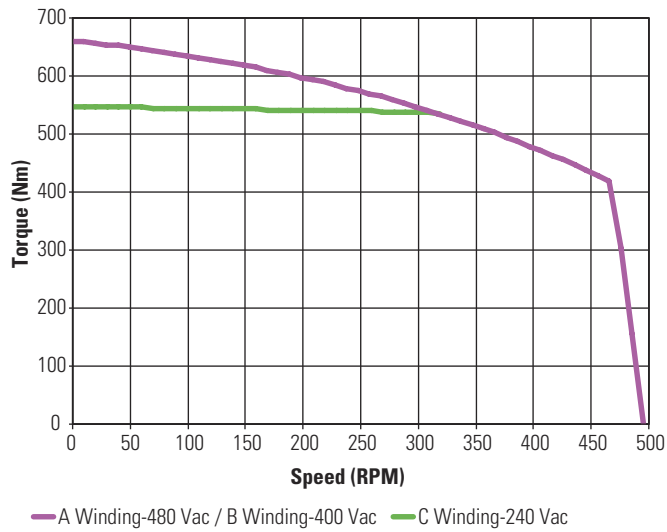

Low Voltage optimized windings available.

Notes

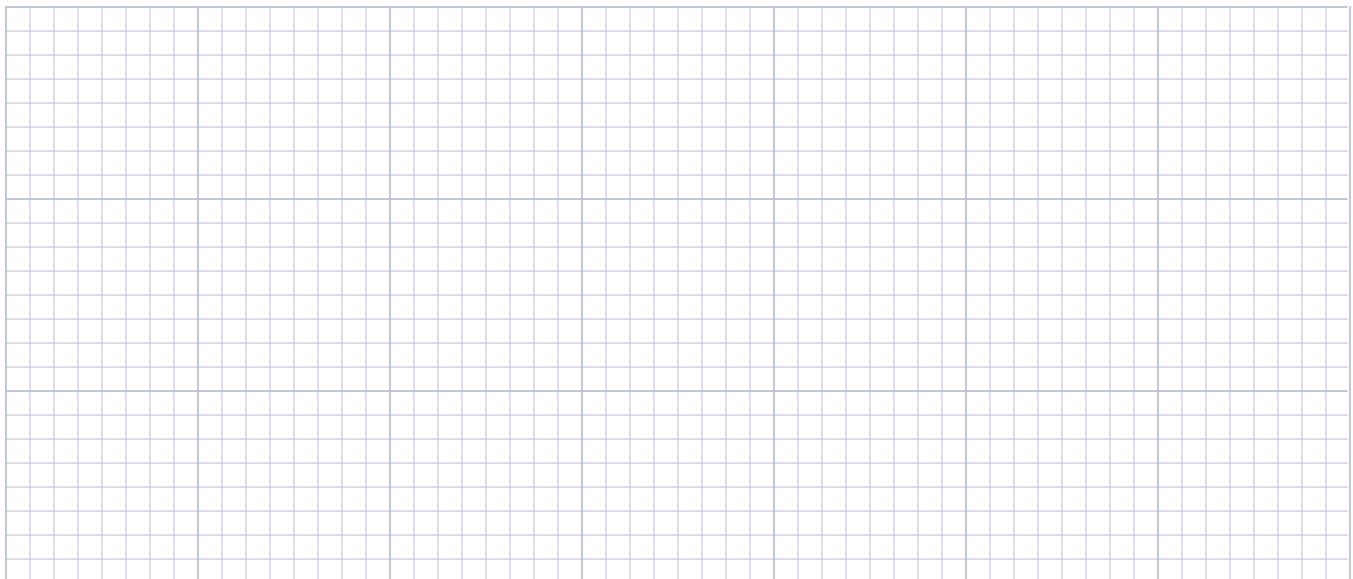

KBM 163 Frameless Motors

K B M 1 6 3

The KBM(S)-163 series provides a classic torque motor footprint - large diameter with short axial length, high pole count, and large rotor thru-bore. Aluminum armature sleeve and steel rotor hub provide pilot diameter engagement surfaces and bolted mounting joints for simple installation. With very low cogging, low total harmonic distortion, and high torque capacity, the KBM(S)-163 is a great performer in the most demanding applications.

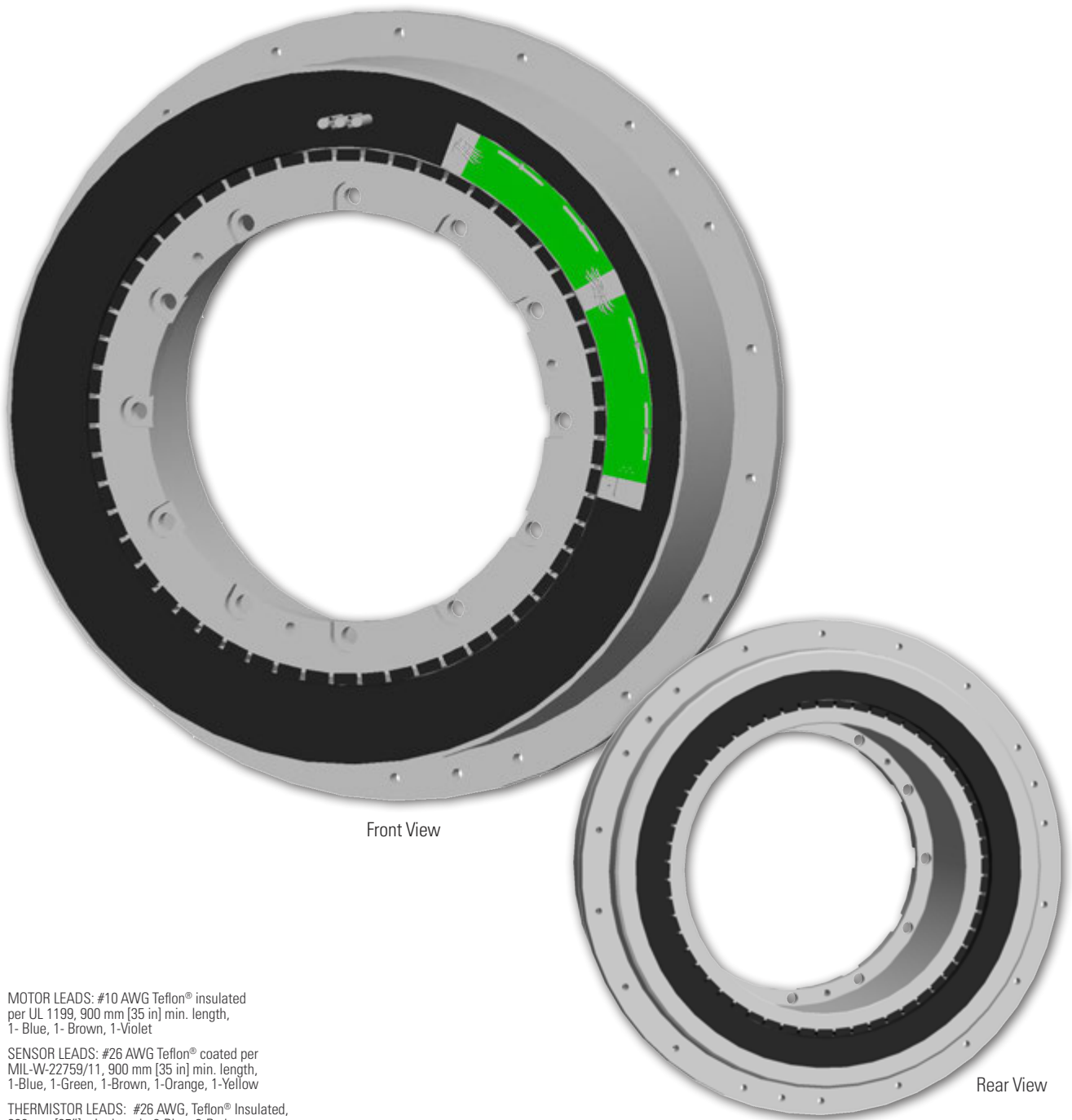

MOTOR LEADS: #10 AWG Teflon® insulated per UL 1199, 900 mm [35 in] min. length, 1- Blue, 1- Brown, 1-Violet

SENSOR LEADS: #26 AWG Teflon® coated per MIL-W-22759/11, 900 mm [35 in] min. length, 1-Blue, 1-Green, 1-Brown, 1-Orange, 1-Yellow

THERMISTOR LEADS: #26 AWG, Teflon® Insulated, 900 mm [35"] min. length, 2-Blue, 2-Red

KBM 163 Outline Drawings

KBM 163

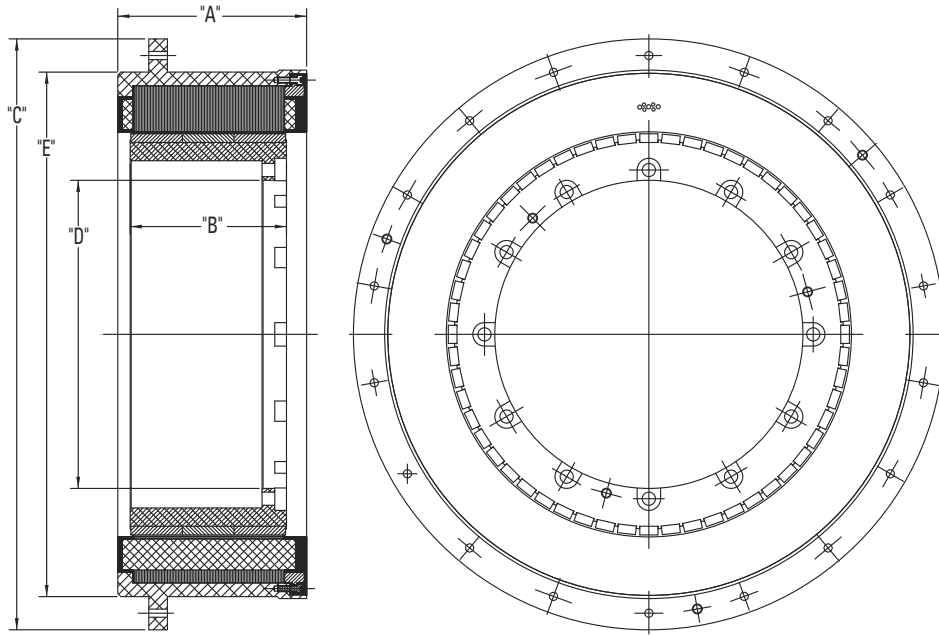

Model Number	"A" mm[inch]	"B" mm[inch]	Ø "C" mm[inch]	Ø "D" mm[inch]	Ø "E" mm[inch]
KBM-163X01	142.54 [5.612]	106.93 [4.210]	605.0 [23.82]	315.50 [12.421]	537.08 [21.145]
KBM-163X02	193.34 [7.612]	160.02 [6.300]			
KBM-163X03	244.14 [9.612]	213.11 [8.390]			

All dimensions are nominal. For more detailed and interactive 3D models with 2D product views, visit www.kollmorgen.com/kbm

KBMS 163

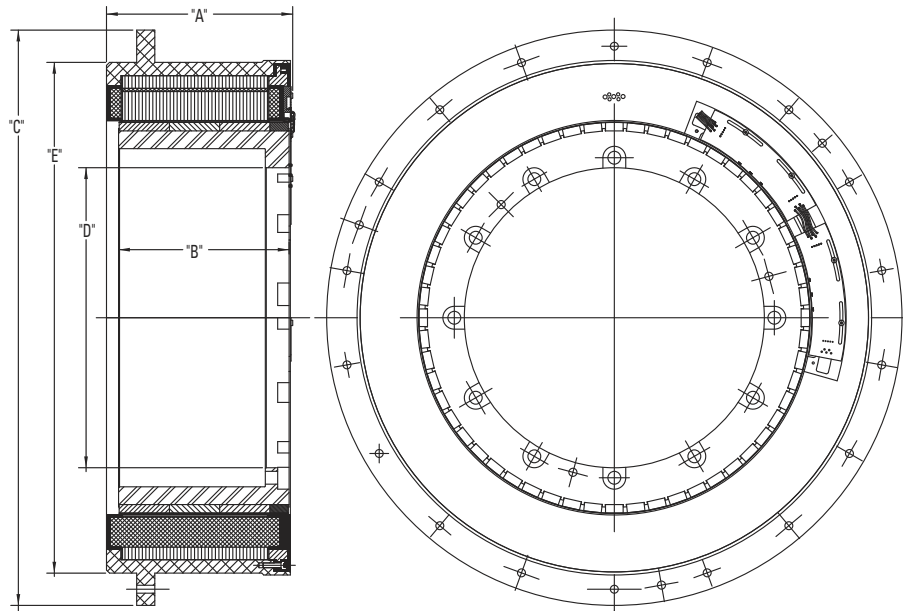

Model Number	"A" mm[inch]	"B" mm[inch]	Ø "C" mm[inch]	Ø "D" mm[inch]	Ø "E" mm[inch]
KBMS-163X01	142.54 [5.612]	126.24 [4.970]	605.0 [23.82]	315.50 [12.421]	537.08 [21.145]
KBMS-163X02	193.34 [7.612]	179.32 [7.060]			
KBMS-163X03	244.14 [9.612]	232.41 [9.150]			

All dimensions are nominal. For additional dimensional data, 2D and 3D drawings, visit www.kollmorgen.com/kbm

KBM 163 Performance Data

KBM(S)-163XXX PERFORMANCE DATA & MOTOR PARAMETERS												
Motor Parameter	Symbol	Units	TOL	KBM(S)-163X01-X			KBM(S)-163X02-X			KBM(S)-163X03-X		
				A	B	C	A	B	C	A	B	C
Continuous Stall Torque at 25°C Amb. (1)	Tc	Nm	NOM	764	764	764	1084	1084	1084	1329	1329	1329
		lb-ft		564	564	564	800	800	800	981	981	981
Continuous Current	Ic	Arms	NOM	41.5	47.0	74.5	39.5	44.0	73.0	38.6	44.0	70.0
Peak Stall Torque (25°C winding temp)	Tp	Nm	NOM	1966	1966	1966	2915	2915	2915	3932	3932	3932
		lb-ft		1450	1450	1450	2150	2150	2150	2900	2900	2900
Peak Current	Ip	Arms	NOM	140	158	253	140	158	253	140	157	253
Rated Continuous Output Power at 25°C Amb. (1)	P Rated	Watts		17300	17400	17300	20100	19120	18065	20100	18810	17420
	HP Rated	HP		23.2	23.3	23.2	26.9	25.6	24.2	26.9	25.2	23.4
Speed at Rated Power	N Rated	RPM		375	350	335	245	225	215	180	165	160
Torque Sensitivity (2)	Kt	Nm / Arms	+/-10%	18.8	16.7	10.4	28.2	25.1	15.7	36.2	32.2	20.1
		lb-ft / Arms		13.8	12.3	7.69	20.8	18.5	11.6	26.7	23.7	14.8
Back EMF Constant	Kb	Vrms/kRPM	+/- 10%	1134	1008	630	1707	1517	948	2188	1945	1216
Motor Constant	Km	Nm/√watt	+/-10%	25.2	25.6	25.5	32.3	32.3	32.3	38.2	38.2	38.2
		lb-ft /√watt		18.6	18.9	18.8	24.0	24.0	24.0	28.2	28.2	28.2
Resistance (line to line)	Rm	Ohms	+/- 10%	0.370	0.286	0.111	0.509	0.394	0.155	0.640	0.495	0.195
Inductance	Lm	mH		4.2	3.3	1.3	6.3	5.0	1.9	8.4	6.6	2.6
Inertia (KBM)	Jm	Kg-m ²		1.06			1.57			1.68		
		lb-ft-s ²		0.785			1.16			1.24		
Weight (KBM)	Wt	Kg		90.7			131			161		
		lb		200			288			355		
Inertia (KBMS)	Jm	Kg-m ²		1.23			1.72			1.83		
		lb-ft-s ²		0.905			1.27			1.35		
Weight (KBMS)	Wt	Kg		96.2			136			166		
		lb		212			300			365		
Max Static Friction	Tf	Nm		9.49			14.2			19.0		
		lb-ft		7.00			10.5			14.0		
Cogging Friction (peak-to-peak)	Tcog	Nm		4.07			5.42			8.13		
		lb-ft		3.00			4.00			6.00		
Viscous Damping	Fi	Nm/ kRPM		182			294			407		
		lb-ft / kRPM		134			217			300		
Thermal Resistance (3)	TPR	°C / watt		0.092			0.075			0.065		
Number of Poles	P	-		56			56			56		
Recommended Kollmorgen AKD Drive				04807			04807			04807		
Recommended Kollmorgen S700 Drive					S772	S772		S772	S772		S772	S772
Voltage Req'd at Rated Output	Vac Input	Vac		480	400	240	480	400	240	480	400	240
Peak Stall Torque (4) (Motor with Drive)	Tp Drive	Nm	+/-10%	1461	1775	1242	2198	2740	1867	2817	3427	2393
		lb-ft		1078	1309	916	1621	2021	1377	2078	2528	1765
Cont. Stall Torque (4) (Motor with Drive)	Tc Drive	Nm	+/-10%	764	764	727	1084	1084	1070	1329	1329	1329
		lb-ft		564	564	536	800	800	789	981	981	981

- Notes
- 1) Winding temperature = 155°C at continuous stall, at rated output, and for performance curves.
 - 2) To calculate no-load Kt and Kb at 25°C, multiply by 1.064.
 - 3) Back EMF is peak (not RMS).
 - 4) Peak & Continuous Torques may be limited by drive current, see www.kollmorgen.com for complete drive ratings.

KBM 163 Performance Curves

Continuous duty capability for 130°C rise in a 25°C ambient using recommended AKD, or S700, servo drive and sinusoidal commutation.

**KBM(S)-163X01
Continuous Torque**

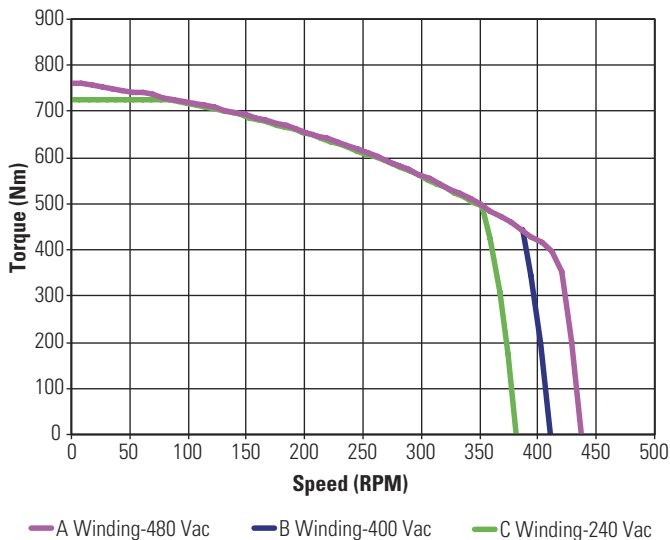

**KBM(S)-163X02
Continuous Torque**

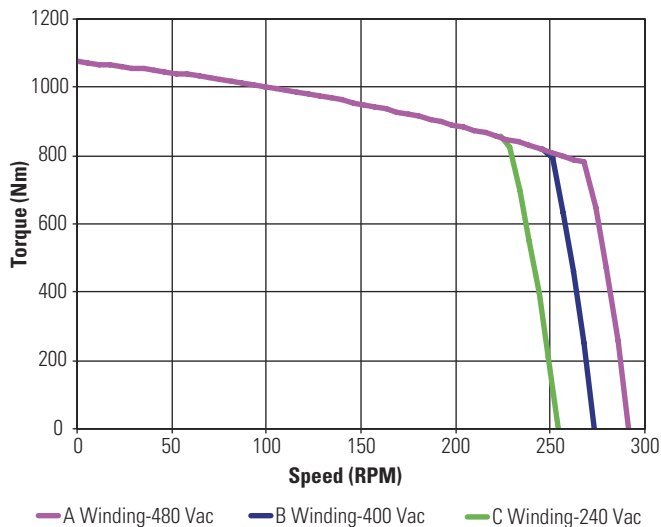

**KBM(S)-163X03
Continuous Torque**

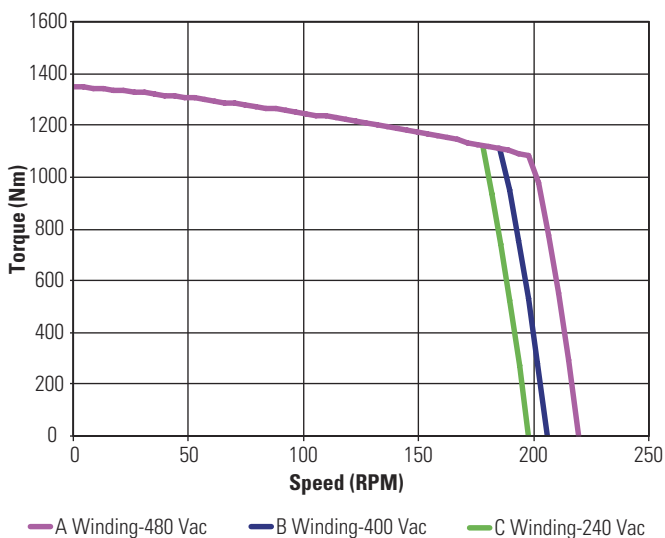

Low Voltage optimized windings available.

KBM 260 Frameless Motors

The KBM(S)-260 series provides a classic torque motor footprint - large diameter with short axial length, high pole count, and large rotor thru-bore. Aluminum armature sleeve and steel rotor hub provide pilot diameter engagement surfaces and bolted mounting joints for simple installation. With very low cogging, low total harmonic distortion, and high torque capacity, the largest member of the KBM(S) family is a great performer in the most demanding applications.

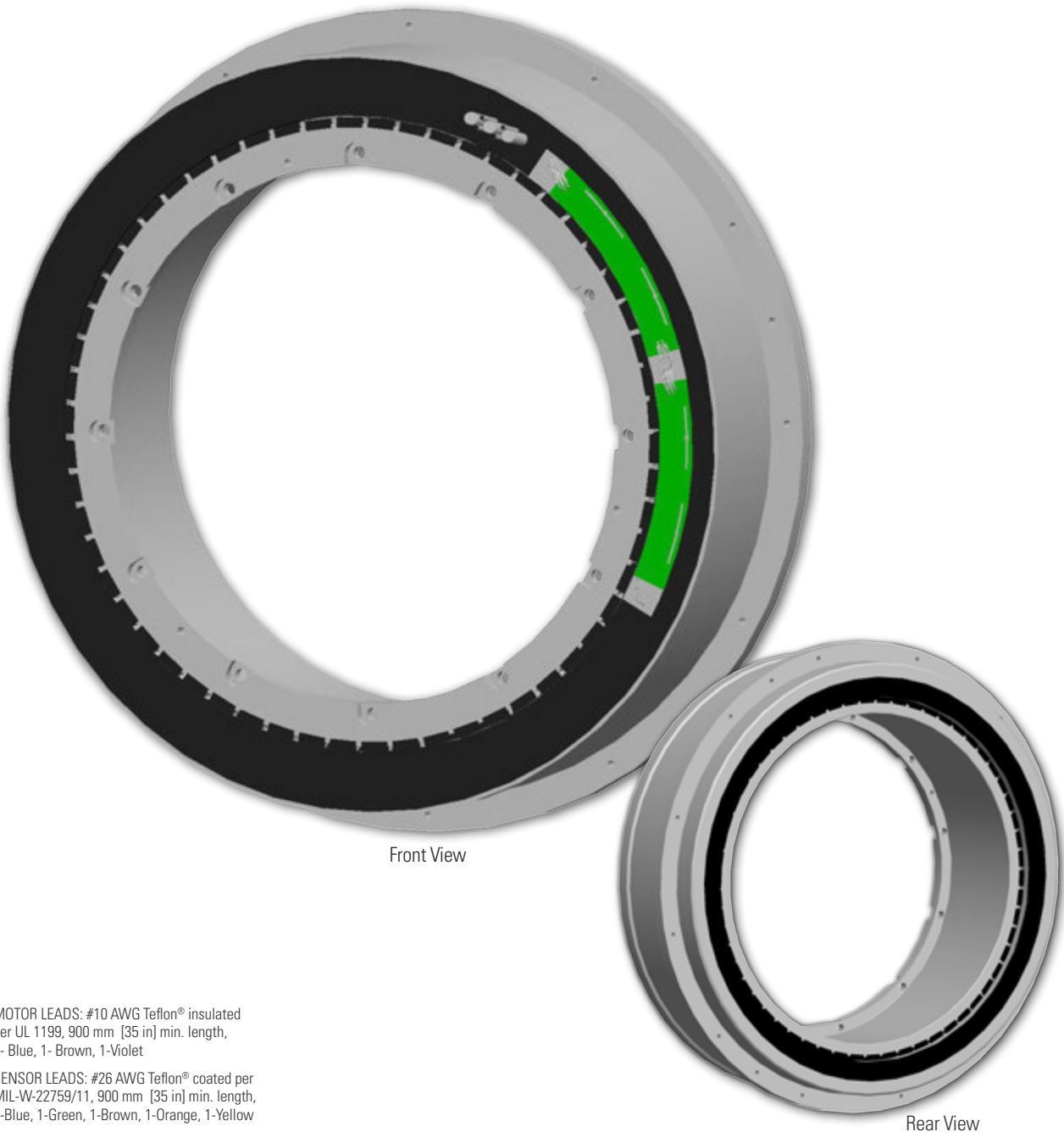

MOTOR LEADS: #10 AWG Teflon[®] insulated per UL 1199, 900 mm [35 in] min. length, 1- Blue, 1- Brown, 1-Violet

SENSOR LEADS: #26 AWG Teflon[®] coated per MIL-W-22759/11, 900 mm [35 in] min. length, 1-Blue, 1-Green, 1-Brown, 1-Orange, 1-Yellow

THERMISTOR LEADS: #26 AWG, Teflon[®] Insulated, 900 mm [35"] min. length, 2-Blue, 2-Red

KBM 260 Outline Drawings

KBM 260

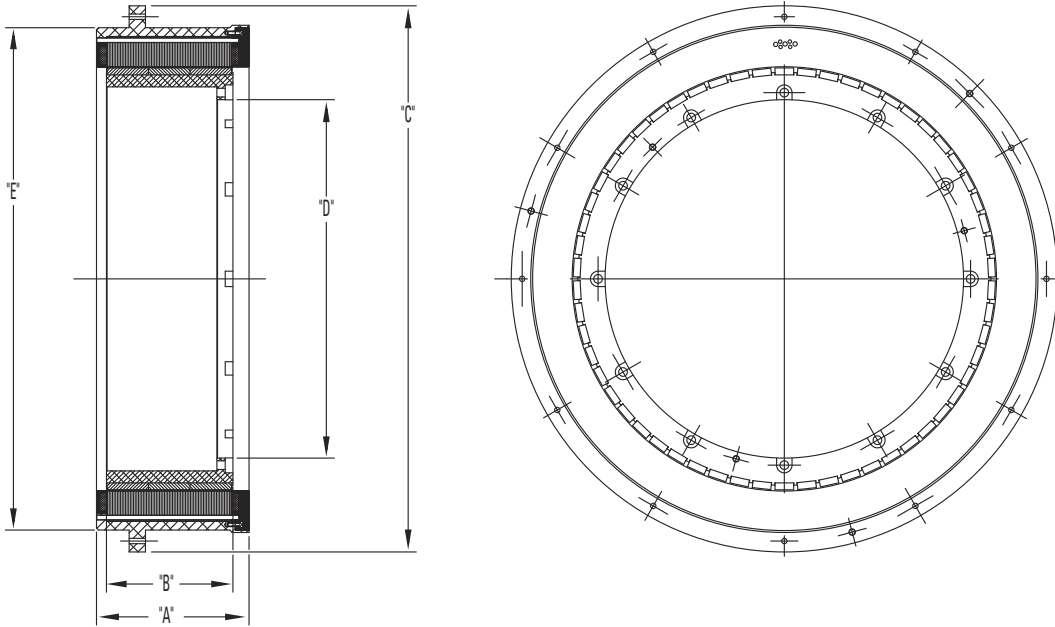

Model Number	"A" mm[inch]	"B" mm[inch]	Ø "C" mm[inch]	Ø "D" mm[inch]	Ø "E" mm[inch]
KBM-260X01	172.62 [6.796]	132.08 [5.200]	850.0 [33.46]	557.85 [21.962]	781.81 [30.780]
KBM-260X02	237.39 [9.346]	196.85 [7.750]			
KBM-260X03	302.16 [11.896]	261.62 [10.300]			

All dimensions are nominal. For more detailed and interactive 3D models with 2D product views, visit www.kollmorgen.com/kbm

KBMS 260

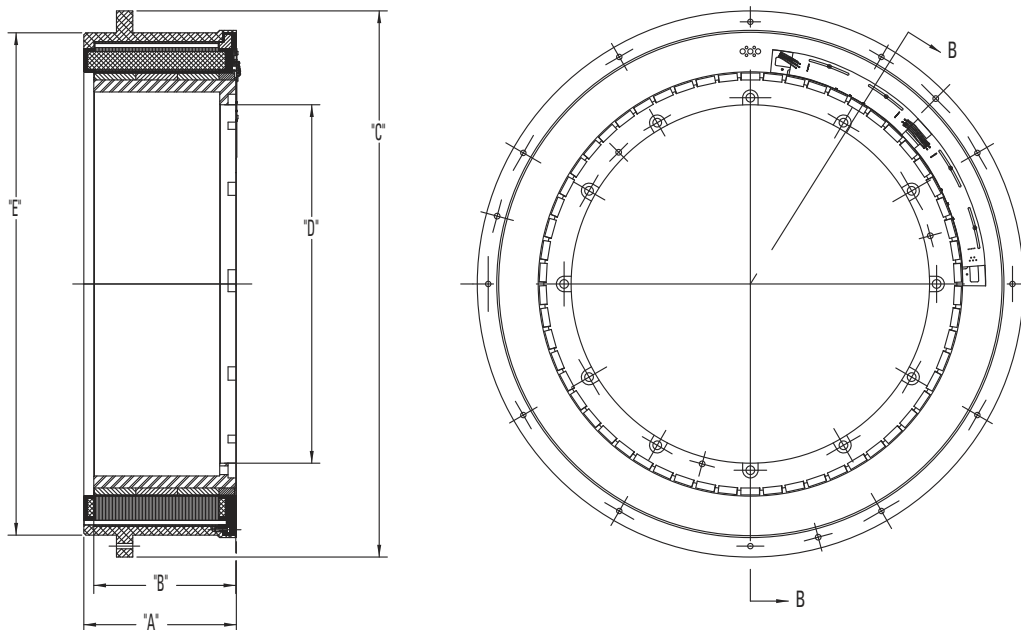

Model Number	"A" mm[inch]	"B" mm[inch]	Ø "C" mm[inch]	Ø "D" mm[inch]	Ø "E" mm[inch]
KBMS-260X01	172.62 [6.796]	156.21 [6.150]	850.0 [33.46]	557.85 [21.962]	781.81 [30.780]
KBMS-260X02	237.39 [9.346]	220.98 [8.700]			
KBMS-260X03	302.16 [11.896]	285.75 [11.250]			

All dimensions are nominal. For additional dimensional data, 2D and 3D drawings, visit www.kollmorgen.com/kbm

KBM 260 Performance Data

KBM(S)-260XXX PERFORMANCE DATA & MOTOR PARAMETERS												
Motor Parameter	Symbol	Units	TOL	KBM(S)-260X01-X			KBM(S)-260X02-X			KBM(S)-260X03-X		
				A	B	C	A	B	C	A	B	C
Continuous Stall Torque at 25°C Amb. (1)	Tc	Nm	NOM	1932	1932	1932	2706	2706	2706	3445	3445	3445
		lb-ft		1425	1425	1425	1996	1996	1996	2540	2540	2540
Continuous Current	Ic	Arms	NOM	33.1	39.0	58.0	31.0	36.5	54.5	29.5	34.5	52.0
Peak Stall Torque (25°C winding temp)	Tp	Nm	NOM	6494	6494	6494	9742	9742	9742	12812	12812	12812
		lb-ft		4790	4790	4790	7185	7185	7185	9450	9450	9450
Peak Current	Ip	Arms	NOM	147	171	257	147	171	257	147	171	262
Rated Continuous Output Power at 25°C Amb. (1)	P Rated	Watts		18500	17675	16100	17150	16400	14715	16200	15570	13710
	HP Rated	HP		24.8	23.7	21.6	23.0	22.0	19.7	21.7	20.9	18.4
Speed at Rated Power	N Rated	RPM		105	100	90	68	65	58	50	48	42
Torque Sensitivity (2)	Kt	Nm / Arms	+/-10%	59.3	50.3	33.9	89.0	76.3	50.9	119	102	67.80
		lb-ft / Arms		43.7	37.5	25.0	65.6	56.3	37.5	87.6	75.0	50.00
Back EMF Constant	Kb	Vrms/kRPM	+/- 10%	3584	3072	2048	5381	4612	3075	7179	6148	4102
Motor Constant	Km	Nm/√watt	+/-10%	47.1	47.1	47.1	59.8	59.8	59.8	70.4	70.4	70.4
		lb-ft /√watt		34.7	34.7	34.7	44.1	44.1	44.1	51.9	51.9	51.9
Resistance (line to line)	Rm	Ohms	+/- 10%	1.06	0.771	0.347	1.48	1.090	0.484	1.90	1.38	0.622
Inductance	Lm	mH		16	12	5.2	24	18	7.8	32	24	10
Inertia (KBM)	Jm	Kg-m ²		4.88			7.19			9.56		
		lb-ft-s ²		3.60			5.30			7.05		
Weight (KBM)	Wt	Kg		170			249			329		
		lb		375			550			725		
Inertia (KBMS)	Jm	Kg-m ²		5.45			7.86			10.2		
		lb-ft-s ²		4.02			5.80			7.55		
Weight (KBMS)	Wt	Kg		177			257			336		
		lb		390			567			740		
Max Static Friction	Tf	Nm		28.5			43.0			57.5		
		lb-ft		21.0			31.7			42.4		
Cogging Friction (peak-to-peak)	Tcog	Nm		17.6			27.1			35.9		
		lb-ft		13.0			20.0			26.5		
Viscous Damping	Fi	Nm/ kRPM		620			1010			1380		
		lb-ft / kRPM		457			748			1020		
Thermal Resistance (3)	TPR	°C / watt		0.050			0.041			0.035		
Number of Poles	P	-		58			58			58		
Recommended Kollmorgen AKD Drive				04807	04807		04807	04807		04807	04807	
Recommended Kollmorgen S700 Drive						S772			S772			S772
Voltage Req'd at Rated Output	Vac Input	Vac		480	400	240	480	400	240	480	400	240
Peak Stall Torque (4) (Motor with Drive)	Tp Drive	Nm	+/-10%	4578	4020	4020	6870	6030	6030	9164	8040	7861
		lb-ft		3377	3317	4267	5067	4448	4448	6759	5930	8520
Cont. Stall Torque (4) (Motor with Drive)	Tc Drive	Nm	+/-10%	1932	1932	1932	2706	2706	2706	3445	3445	3445
		lb-ft		1425	3317	4267	1996	1996	1996	2541	2541	2541

- Notes
- 1) Winding temperature = 155°C at continuous stall, at rated output, and for performance curves.
 - 2) To calculate no-load Kt and Kb at 25°C, multiply by 1.064.
 - 3) Back EMF is peak (not RMS).
 - 4) Peak & Continuous Torques may be limited by drive current, see www.kollmorgen.com for complete drive ratings.

KBM 260 Performance Curves

Continuous duty capability for 130°C rise in a 25°C ambient using recommended S700 servo drive and sinusoidal commutation.

**KBM(S)-260X01
Continuous Torque**

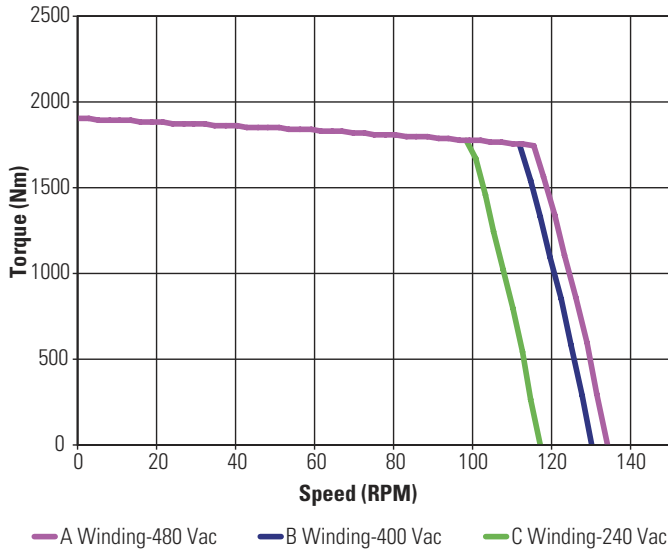

**KBM(S)-260X02
Continuous Torque**

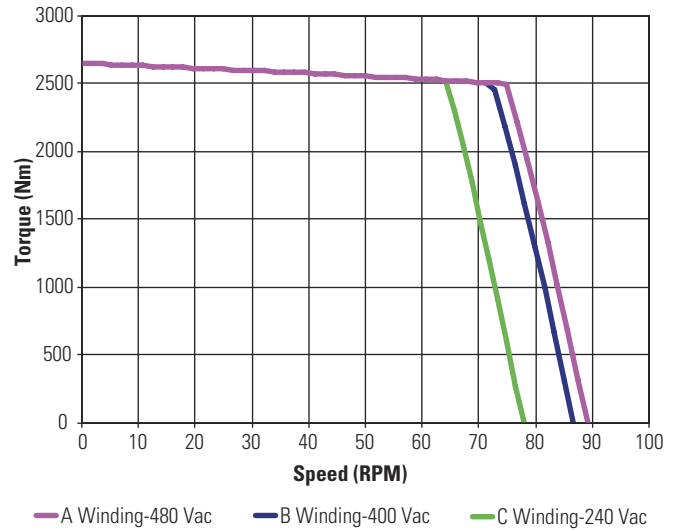

**KBM(S)-260X03
Continuous Torque**

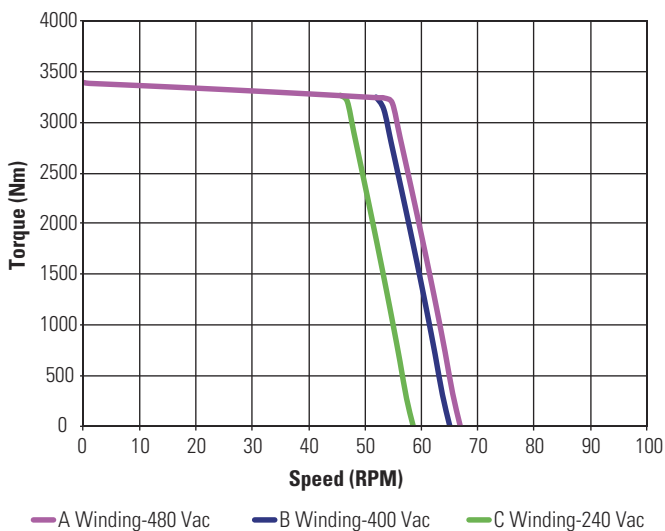

Low Voltage optimized windings available.

Mounting and Installation Guidelines

Safety

Safety Notes



The strong magnetic fields which are produced as long as the magnetic rotor is not installed, constitute a hazard for persons with implants, such as cardiac pacemakers, that can be influenced by magnetic fields. As a general rule, all persons who may suffer impairment to health through the influence of strong magnetic fields must keep at a safe distance of at least 1 meter from the rotor.



The strong magnetic fields which are produced constitute a hazard for persons with implants that can be influenced by magnetic fields. As a general rule, all persons who may suffer impairment to health through the influence of strong magnetic fields must keep at a safe distance of at least 1 meter from the motor.

Only properly qualified persons are permitted to perform activities such as transport, installation, commissioning and maintenance. Properly qualified persons are those who are familiar with the transport, assembly, installation, commissioning and operation of motors, and who have the appropriate qualifications for their job. Qualified personnel must know and observe the following standards and directives: IEC 60364, 60662 and national accident prevention regulations.

The recommendations included in this document are intended to serve as general installation guidelines, and are for reference purpose.

Kollmorgen assumes no responsibility for incorrect implementation of these techniques, which remain the sole responsibility of the user.



Always wear gloves when working on the motor.

Read the available documentation before installation and commissioning. Incorrect handling of the motor components can cause injury and damage to persons and equipment. Special care must be taken when installing the rotor inside the stator of the motor. Tooling or fixtures may be required.



Eye bolts used for lifting the rotor/stator must be rotatable, because fixed eye bolts can bend or break due to side loads if improperly aligned with lift hooks. Swivel eye bolts remove this risk. Use 3 eye bolts equally spaced for lifting rotor and stator to make sure, that the load is under control. Refer to the dimension drawing hardcopy in the package to detect the mounting hole positions for installing the eye bolts.



Strong magnetic fields attract metallic objects and create potential safety hazards for hands and fingers. During work on or in the vicinity of KBM motors make sure that at least two finely pointed wedges of tough non-magnetic material - e.g. V2A - (with a wedge angle of approx. 10°-15°) and a non-metallic hammer (approx. 3 kg) are at hand. In an emergency you can then use these tools to detach objects that are magnetically bound to the magnetic rotor (for instance, to free trapped parts of the body).

Keep watches and magnetic data media (credit cards, diskettes, etc.) and digital displays (mobile phones, laptops, etc.) out of the immediate vicinity (<500 mm) of the KBM motor. Because of the high forces of attraction, special care must be taken within a range of about 50 mm from the magnetic rotor. Inside this area, heavy (>1 kg) or large-area (>1 dm²) objects of steel or iron must not be held in the hand.

The rotor must never be stored in an unpacked condition. Use non-magnetic packaging material that is at least 20 mm thick. The storage location must be dry and protected from heat. Do not expose the motor rotor to heat in excess of 100°C, unless installed inside the stator. Heat over 100°C can de-magnetize the rotor magnets.

Put up warning signs where the motors are stored:
Caution: STRONG MAGNETS

Attach easily visible warning signs (e.g. permanent self-adhesive labels) to the machine:
Caution: The drives on this machine are fitted with strong magnets.
STRONG MAGNETIC FIELDS + HIGH ATTRACTION FORCES!



It is mandatory to ensure that the metallic parts of the motor stator are properly grounded to the PE (protective earth) busbar in the switchgear cabinet. Safety for personnel cannot be assured without a low-resistance protective earth. See Grounding section of Mounting and Installation Guidelines of this documentation for more detailed information.

Power connections may still be live, even though the motor is not moving. Never undo the electrical connections to the motor while a voltage is present. In unfavorable cases this can cause arcing, with injury and damage to persons and equipment.

The thermal element in the stator windings (PTC or KTY) must be wired to the control circuit of the application to make sure, that the motor temperature is supervised and the motor is protected from overheating. It must be ensured, that winding temperature never exceeds 155°C.

Mounting and Installation Guidelines

Use as Directed

- The KBM series of permanent magnet frameless motors is designed especially for motion applications for industrial robots, machine tools, textile, packing machinery and similar machines with high requirements for dynamic positioning and servo movement.
- The user is only permitted to operate the motors under the ambient conditions which are defined in this documentation.
- The series of motors is exclusively intended to be driven by servo amplifiers under speed and / or torque control.
- The motors are installed as components in electrical apparatus or machines and can only be commissioned and put into operation as integral components of such apparatus or machines.
- The thermal resistor which is integrated in the motor windings must be supervised and evaluated.
- The conformity of the KBM motor to the standards mentioned in the EC Declaration of Conformity is only guaranteed when installed in accordance with the Mounting & Installation Guidelines in this documentation. The end user assumes responsibility for machine conformity.
- The KBM motor only use UL/UR approved materials and is designed in full compliance with agency creepage and clearance dimensional guidelines.
The End User assumes responsibility for machine conformity.

Prohibited Use

The use of the motors in the following environments is prohibited:

- potentially explosive areas
- environments with corrosive and/or electrically conductive acids, alkaline solutions, oils, vapors, dusts
- vacuum
- directly on supply networks , mains

Commissioning the motor is prohibited if the machine in which it was installed

- does not meet the requirements of the EC Machinery Directive
- does not comply with the EMC Directive
- does not comply with the Low Voltage Directive

Package Delivered

The weight of the package which you receive depends on the number of parts inside. The weight given below always means the maximum possible weight for the package.

Motor Type	Packaging	Max Shipping Container Weight [kg]
KBM10 to 43	Reinforced fiberboard box with inner padding, hand lifted	31
KBM45	Wooden crate with inner padding, lift with hoist	60
KBM57	Reinforced fiberboard box with inner padding, hand lifted	40
KBM60	Wooden crate with inner padding, lift with hoist	60
KBM79	Wooden crate with inner padding, lift with hoist	102
KBM88	Wooden create with inner padding and pallet base, lift with fork truck	135
KBM118	Wooden crate with inner padding, lift with hoist	110
KBM163	Wooden create with inner padding and pallet base, lift with fork truck	190
KBM260	Wooden create with inner padding and pallet base, lift with fork truck	350

Transport

Transport of the package

- Climate category 2K3 to EN61800-2
- Transport temperature -25...+70°C, max. 20K/hr change
- Transport humidity rel. humidity 5% - 95%, no condensation
- Max. stacking height see table in chapter "Storage"
- Max. weight see table in chapter "Package delivered"
- Avoid shocks. If the packaging is damaged, check the motor parts for visible damage. Inform the carrier and, if appropriate, the manufacturer.

Transport of motor parts

- Pay attention to the Safety Notes given at the beginning of these guidelines.
- Wear gloves and prepare the described emergency tools (wedges and hammer)
- Tapped holes for lifting in rotor only for sizes 43 thru 118.
Tapped holes for lifting in rotor and stator for sizes 163 - 260. See detailed outline drawings added to the package for detecting the holes.
- Use minimum 3 swivel eye bolts equally spaced.

Motor Type	Transport Tool	Preparation	Weight Rotor [kg]*	Weight Stator [kg]*
KBM10	hand carry or wheeled cart	–	0.25	1
KBM14	hand carry or wheeled cart	–	0.5	2
KBM17	hand carry or wheeled cart	–	0.8	3
KBM25	hand carry or wheeled cart	–	1.5	5
KBM35	hand carry or wheeled cart	–	3	8
KBM43	hand carry or wheeled cart	–	2.5	12
KBM45	hoist or wheeled cart	–	6	18
KBM57	hand carry or wheeled cart	–	6	30
KBM60	hoist or wheeled cart	Tapped mounting holes in rotor will accept eye bolts for lifting. Stator to be lifted with a web sling.	6	40
KBM79	hoist or wheeled cart	Tapped mounting holes in rotor will accept eye bolts for lifting. Stator to be lifted with a web sling.	15	56
KBM88	hoist, pallet jack, fork truck	Tapped mounting holes in rotor will accept eye bolts for lifting. Stator to be lifted with a web sling.	37	75
KBM118	hoist or wheeled cart	Dedicated tapped holes in rotor accept eye bolts for lifting. Stator to be lifted with a web sling.	35	56
KBM163	hoist, pallet jack, fork truck	Dedicated tapped holes in rotor and stator accept eye bolts for lifting.	46	105
KBM260	hoist, pallet jack, fork truck	Dedicated tapped holes in rotor and stator accept eye bolts for lifting.	97	210

* worst case weight (heaviest, rounded) listed for longest length version within this diameter size

Mounting and Installation Guidelines

Storage

Climate category	1K4 to EN61800-2
Storage temperature	-25 to +55°C, max. variation 20K/hr.
Humidity	rel. humidity 5% - 95%, no condensation
Storage time	unlimited.

Maximum Stacking Height

Motor Type	Maximum Stacking Height	Motor Type	Maximum Stacking Height
KBM10	3	KBM57	3
KMB14	3	KMB60	2
KBM17	3	KBM79	2
KBM25	3	KBM88	1
KBM35	3	KBM118	1
KBM43	3	KBM163	1
KBM45	2	KBM260	1

Operation

Ambient temperature (at rated values)	+5 to +25°C for site altitude up to 1000 m amsl
Permissible humidity (at rated values)	95% rel. humidity, no condensation
Power derating (currents and torques)	No derating for site altitudes above 1000 m amsl with temperature reduction of 10K / 1000 m. It must be ensured, that winding temperature doesn't exceed 155°C.

Important Note: The recommendations included in this Kollmorgen selection guide are intended to serve as general installation guidelines, and are for reference purposes only. Kollmorgen assumes no responsibility for incorrect implementation of these techniques, which remain the sole responsibility of the user.

KBM(S) series motors, as well as any other Kollmorgen frameless brushless motors that are supplied as 2-piece rotor/stator components, should be installed by the user according to the general guidelines below.

User Interface Responsibilities

To assure proper performance and reliability of the motor when installed in the system, the user is responsible for designing the mounting interface using the following information as a guideline. The user is responsible for designing the rotor shaft, stator enclosure, bearing system, housing design details, material selection, fit calculations and tolerance analysis based on the needs of the intended application.

Bearings

The user-supplied bearing system in the motor application must exhibit sufficient stiffness to maintain a rigid, uniform clearance gap between the rotor and the stator under all operating conditions.

Typical Radial Running Clearance

		Models KBM(S)													
		10X	14X	17X	25X	35X	43X	45X	57X	60X	79X	88X	118X	163X	260X
Nominal Mechanical Gap	mm	0.38	0.43	0.43	0.44	0.45	0.64	0.51	0.64	0.64	0.70	0.64	0.76	1.9	1.9
	in	0.015	0.017	0.017	0.017	0.018	0.025	0.020	0.025	0.025	0.028	0.025	0.030	0.075	0.075

Concentricity requirements noted on each model-specific Kollmorgen outline drawing (website download or hardcopy inside the package) must be considered by the user. Bearings with the lowest possible friction and high quality lubricant should be chosen to minimize overall system friction, which allows optimal motor operation.

Stator Mounting Materials

A metallic housing/clamp structure is suggested to rigidly mount the stator to assure best conductive heatsinking path and proper structural integrity. Aluminum alloys are preferred due to their superior thermal conductivity and strength-to-weight ratio, although stainless steel alloys (300 series or equivalent) are an acceptable alternative for applications that are less thermally critical. Carbon steel, cast iron, 400 series stainless alloys and other magnetic flux-conducting ferrous metals are the least desirable choices for stator mounting, but can certainly be used in some cases if proper design choices are considered. Consult a Kollmorgen engineer for assistance if such metals must be used. Plastics or other similar thermally isolating materials are not recommended, since they adversely affect the heatsinking capacity of the system, making it necessary to significantly de-rate the motor's performance.

Rotor Mounting Materials

The magnetized rotor may be mounted to any metallic shaft of the user's choice. Carbon steel and stainless steel are the most commonly used shaft materials, although aluminum alloys are occasionally used if properly designed for the intended torque and thermal operating range. The user's intended method of attaching the rotor to the shaft may influence the optimum material and tolerance choices for the shaft. The user's shaft does not need to carry flux or function as a portion of the magnetic circuit to achieve rated performance when using a Kollmorgen brushless motor.

Grounding

When mounted in the application, the laminated stack (or bare metal outer sleeve) of the stator should be at the same electrical ground potential as the system chassis and the drive amplifier chassis. If this common ground path is not ensured, the application may exhibit electrical noise and also create an electrical shock hazard. The risk of shock is particularly prevalent when using high pole-count motors with large capacitance characteristics. Typically, if the stator is mounted using electrically conductive metallic components, then a robust ground path between stator stack and machine chassis is inherently achieved. Kollmorgen suggests performing a continuity check to confirm proper ground path before enabling the motor system. In some applications, depending on mounting configuration and materials chosen by the user, a separate conductive ground strap may be required. In such cases, the user is responsible for installation of the ground path and electrical verification.

Mounting and Installation Guidelines

Stator Mounting

Kollmorgen suggests the following options for installation of the motor stator depending on torque, vibration and thermal characteristics of the application, as well as cost, ease of assembly and serviceability desired by the user.

Bonding with Structural Adhesives

In most cases, motors in the general peak torque range up to 2400 Nm may have the stator bonded in place using a structural epoxy, such as Hysol® EA934NA, 3M™ Scotchweld™ 2214 or other similar adhesives. Bonding is a preferred installation technique for KBM(S)-10 through KBM(S)-118 size stators. Bonding can certainly be used to secure stators larger than the aforementioned size range if desired, but requires additional design and process considerations. To successfully utilize adhesive bonding, the user's stator enclosure should be designed as a cylindrical cup, as shown in the illustration below, with a small shoulder for axial positioning at one end and open at the opposite end.

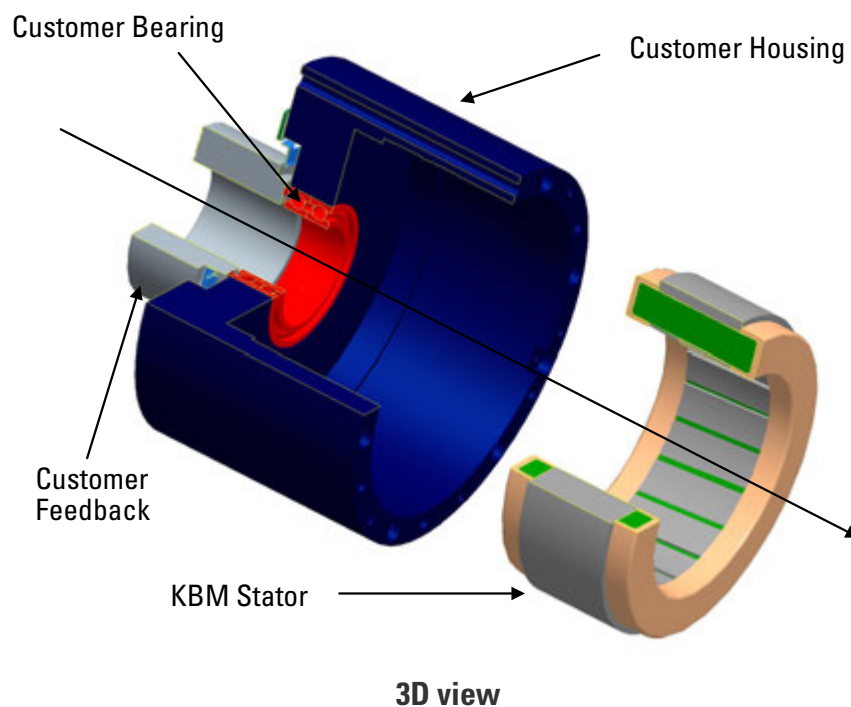

The shoulder serves as a stop point for the stator to bank against when inserted from the open end, and should generally clear the maximum outer diameter of the winding end-turn by no less than 2 mm at all circumferential points. Refer to Detail A.

A small internal chamfer at the open end of the housing cup simplifies stator insertion. If using a thick structural epoxy, the inner diameter of the housing cup should be approximately 0.1 mm - 0.2 mm larger than the maximum outer diameter of the stator. However, the user should consult the adhesive manufacturer for proper bond line thickness, application process and curing instructions. The grooves shown in the inner diameter of the housing in the Detail A illustration are intended to serve as adhesive reservoirs for the thick structural epoxy which will provide significant torsional strength across a broad temperature range. Temperature extremes create the potential issue of dissimilar expansion coefficients [steel laminations vs. aluminum housing]. These bonding agents provide excellent life and strength characteristics over time when used in the manufacturers recommended manner. If the assembly procedure is performed with the stator housing laying flat [rotation axis vertical], the hydrostatic pressure of the structural adhesive will cause the stator to self-center within the stator housing.

If a retaining compound, such as Loctite ® 640™ or other similar adhesive, is preferred instead of a structural epoxy, a tighter clearance between housing inner diameter and stator outer diameter must be controlled to maintain appropriate bond line thickness. Refer to adhesive manufacturer’s guidelines for recommendations. User assumes responsibility for selecting proper adhesive and for designing housing dimensions per expected thermal growth rate at intended temperature extremes of application. Adhesive cure temperatures should not exceed 155°C to avoid damaging the motor stator (150°C for KBMS models). Stator and housing surfaces should be cleaned thoroughly prior to bonding to ensure good adhesion.

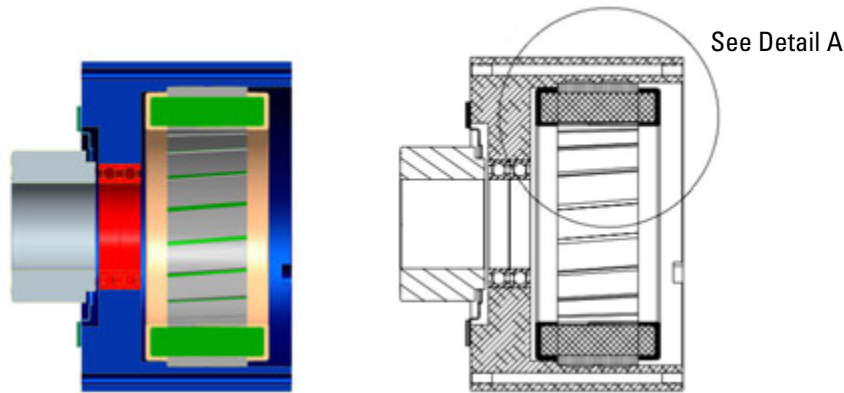

2D view

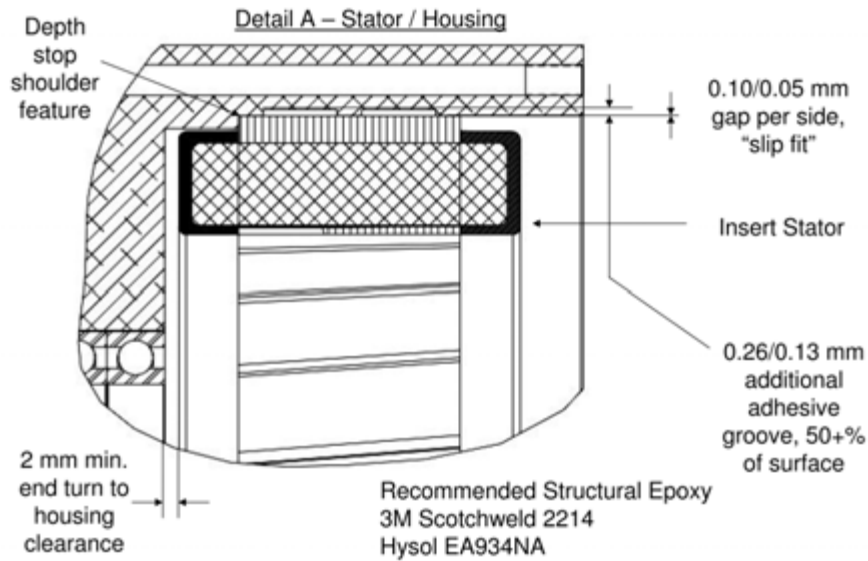

Detail A – Stator/Housing

Mounting and Installation Guidelines

Axial Clamping

For low to moderate torque applications or for applications where the stator may need to be repeatedly installed and removed from the system, axial clamping may be an acceptable option. Kollmorgen does not generally recommend this technique for high shock and vibration applications, extreme temperature applications, or for peak torques greater than 50 Nm without special design consideration. The stator enclosure shown in the illustration below is very similar to the epoxy bonding technique. When using the clamping technique for mounting the stator, the inner diameter of the housing cup should be approximately 0.05 mm - 0.10 mm larger than the maximum outer diameter of the stator. A machined shoulder feature which will serve as a stop point for the stator to bank against when inserted from the open end is recommended. This shoulder dimension should clear the maximum outer diameter of the winding end-turn by no less than 2 mm at all circumferential points. A separate clamp ring with the same circumferential clearance to the winding end turns is placed over the opposite end of the stator and bolted [typically 4 to 12 fasteners, equally spaced] to the housing enclosure. The user should design the enclosure components to ensure that, with the stator installed, an axial clearance gap exists between the clamp ring and the end of the housing at all tolerance conditions. Otherwise, the clamp ring could contact the housing before the fasteners are fully tightened, which

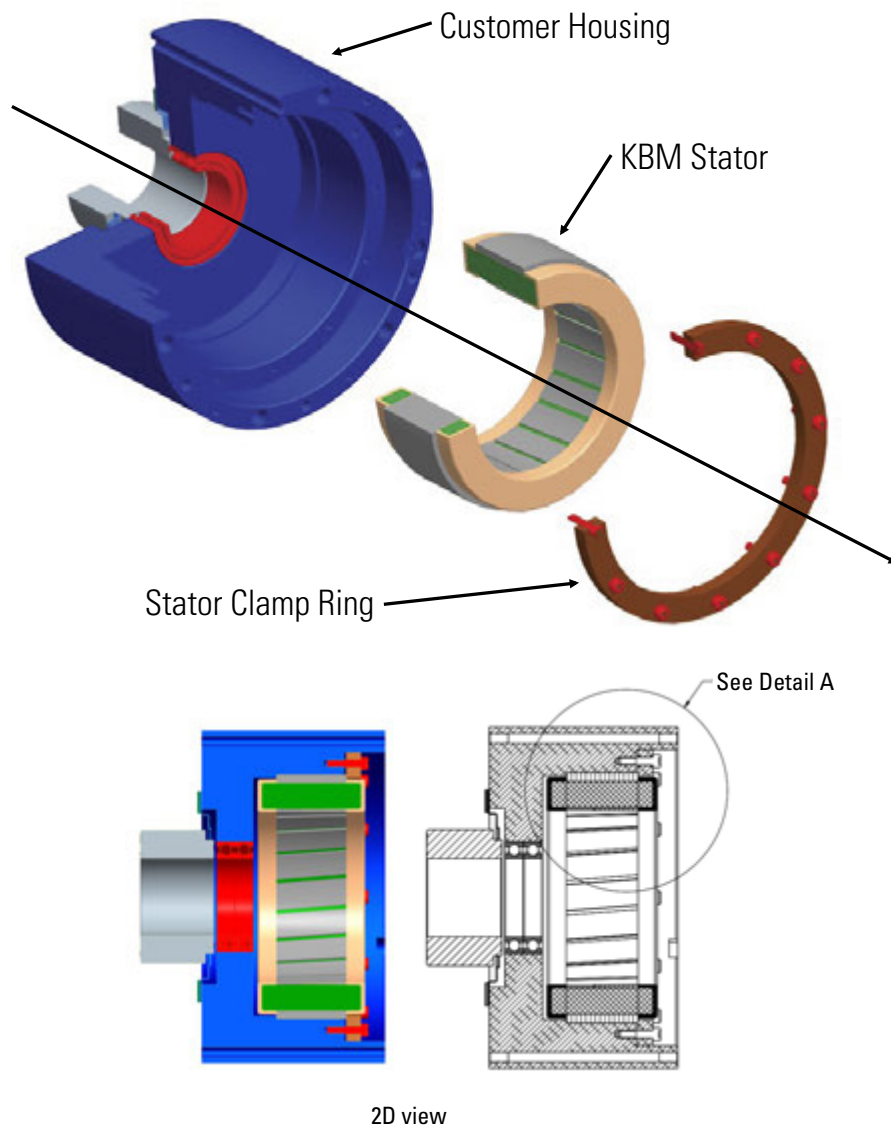

would result in insufficient axial clamping force against the stator. If desired, the small radial space between the stator outer diameter and the housing inner diameter may be filled with a thermal compound for more efficient conduction to the heatsink. However, use caution to avoid contaminating the axial clamping surfaces with grease that may lead to reduced clamping force. If the user wishes to evaluate this axial clamping technique for motors with higher peak torque ratings, it may be necessary to increase the total surface area of the clamping regions and increase the number of clamping fasteners.

Bolting

Sizes KBM(S)-163XXX and KBM(S)-260XXX are supplied with the stator installed in an aluminum sleeve with flange and through-holes for bolted mounting. User interfaces for these large motors should be designed per the pilot diameters and hole patterns shown on the Kollmorgen model-specific outline drawings. Several of the smaller sizes within this motor family, such as KBM(S)-10XXX through KBM(S)-45XXX range, are also supplied with the stator installed inside an aluminum sleeve, but do not include a stepped flange and are not intended to be bolted in place. For the latter range of sizes, bonding, or clamping techniques described in previous sections are appropriate.

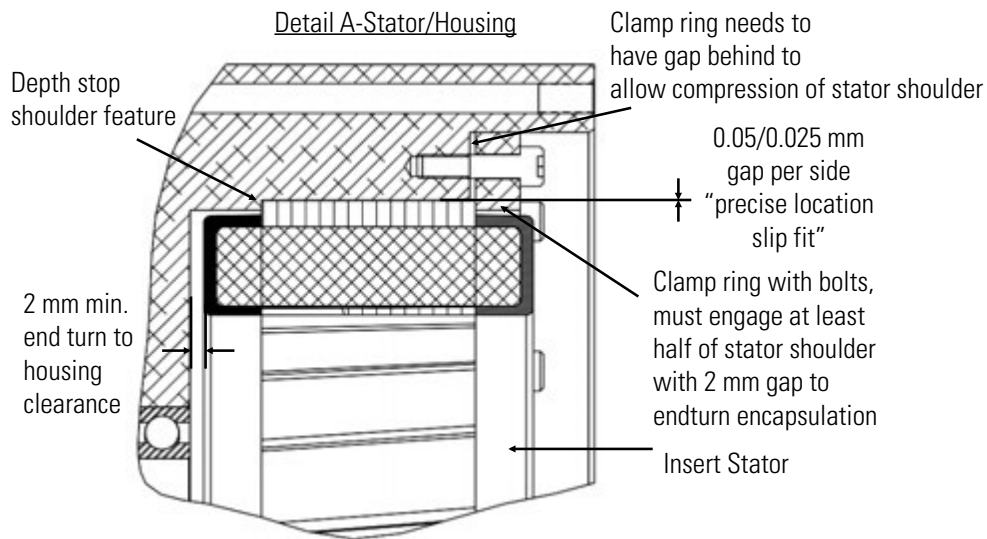

Mounting and Installation Guidelines

Rotor Mounting to Shaft

Kollmorgen's KBM(S) series and other frameless brushless motors utilize high-performance rare earth magnets. Use extreme caution when handling or transporting to avoid injury and product damage. The attractive forces between magnetized rotors and nearby metallic objects can be extremely powerful. Improper handling can result in sudden unexpected impacts. The strong magnetic field can also damage nearby computers, display screens and memory storage devices. Keep the rotor in its shipping container or wrapped protectively until ready to install. This practice will help avoid accidents and prevent contamination such as metallic chips or debris that tend to cling to the magnets.

Axial Alignment Control

Kollmorgen's model-specific outline drawings note axial alignment that must be maintained between rotor and stator when mounted to ensure proper motor performance. The user is responsible for designing the rotor shaft, stator enclosure and bearing system to achieve the specified mounting alignment. Machined shoulders on the shaft or grooves for removable retaining rings are common ways of controlling rotor installation position. Maximum diameter of retaining rings or shaft shoulders should be kept below the rotor diameter where magnets are bonded to the steel hub.

Bonding

Generally, for applications where peak torque does not exceed 750 Nm, rotors can be bonded to carbon steel or stainless steel shafts. Retaining compounds, such as Loctite 640 or other similar adhesives, usually require smooth continuous interface diameters and tight fit tolerances. Structural epoxies generally require slightly larger fit clearance to allow a thicker bond line. Epoxies often benefit from grooves in the shaft/rotor interface that function as adhesive reservoirs and may be enhanced by textured machined surfaces via knurling or grit blasting. Always clean the bond joint surfaces thoroughly to ensure good adhesion. Consult adhesive manufacturer for proper bond line thickness, fit tolerances, process details and curing guidelines. To avoid partial demagnetization of the rotor, do not cure rotor/shaft bond joints at temperatures $> 82^{\circ}\text{C}$ unless rotor is nested inside the matching stator or rotor is completely surrounded by a ferrous metal keeper fixture. Contact a Kollmorgen engineer if more information is required on this topic. Before bonding rotors to aluminum shafts, consult with adhesive manufacturer for assistance. A highly flexible adhesive with broad thermal properties may be required.

Bonding example showing the KBM-43X03 rotor:

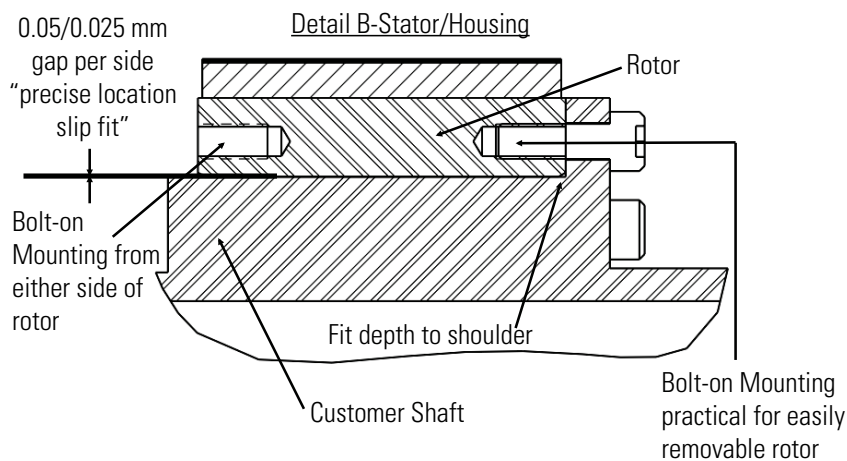

Axial Clamping

If the user's shaft is designed with a machined shoulder that the rotor can rigidly bank against, the rotor may be axially clamped in place using a locknut. The locknut technique allows the rotor to be installed and removed from the shaft repeatedly, but requires a portion of the shaft to be threaded. Rotors retained by locknuts may be generally suitable for applications up to 400 Nm peak torque, although this estimate may vary greatly depending upon size and type of nut used.

Bolting

The KBM(S)-43XXX and the KBM(S)-57XXX through the KBM(S)-260xx frame sizes are provided with hole patterns in the rotor hub to facilitate bolted mounting. User shaft interface should be designed per the diameter, length, axial position and hole pattern noted on the Kollmorgen model-specific outline drawing. KBM(S)-10XXX through KBM(S)-35XXX and KBM(S)-45XXX models may be ordered with a mounting bolt circle on the rotor as an option.

Pre-selected Bolt Circle Diameters and Bolt size options are provided in Table A below.

Rotor flanges with metric through holes may also be provided as an option for mounting in accordance with Table B below.

Add Rotor Metric Tapped Holes				
Model	Max ID (mm)	Max Bolt Circle (mm)	Suggested Hole Size	Suggested Hole Qty
KBM10	5	10.5	M2.5X.45	6
KBM14	7	13.5	M3x.5	6
KBM17	17	23.5	M3x.5	8
KBM25	33	41.5	M4x.7	8
KBM35	48	56.5	M4x.7	8
KBM43	Existing (contact Kollmorgen for custom request)			
KBM45	65	75	M5x.8	8
KBM57	Existing (contact Kollmorgen for custom request)			
KBM60				
KBM79				
KBM88				
KBM118				
KBM163				
KBM260				

Table A

Add Rotor Flange with Thru-Holes				
Model	Max ID (mm)	Max Bolt Circle (mm)	Suggested Hole Size (mm)	Suggested Hole Qty
KBM10	5	10.5	3.0	6
KBM14	7	13.5	3.7	6
KBM17	17	23.5	3.7	8
KBM25	33	41.5	4.8	8
KBM35	48	56.5	4.8	8
KBM43	56	66	5.8	8
KBM45	65	75	5.8	8
KBM57	81.5	93	6.8	8
KBM60	82.02	93.5	6.8	12
KBM79	124	138	8.8	8
KBM88	120	138	10.8	12
KBM118	NOT RECOMMENDED FOR THIS SIZE MOTOR			
KBM163				
KBM260				

Table B

Mounting and Installation Guidelines

Assembly – Installing Rotor Inside Stator

As previously described, magnetic forces can be extremely powerful and may surprise the user when handling or installing the rotor. Extreme caution is required when placing the rotor inside the stator. Data for each KBM model can be determined from the Force Summary Table below.

Radial and Axial forces between Rotor and Stator

When the rotor is off-center with respect to the stator, there are radial forces created that are proportional to the radial eccentricity. The table below gives a summary of these radial forces showing a nominal force per 25 mm of active stack length for each motor series frame size.

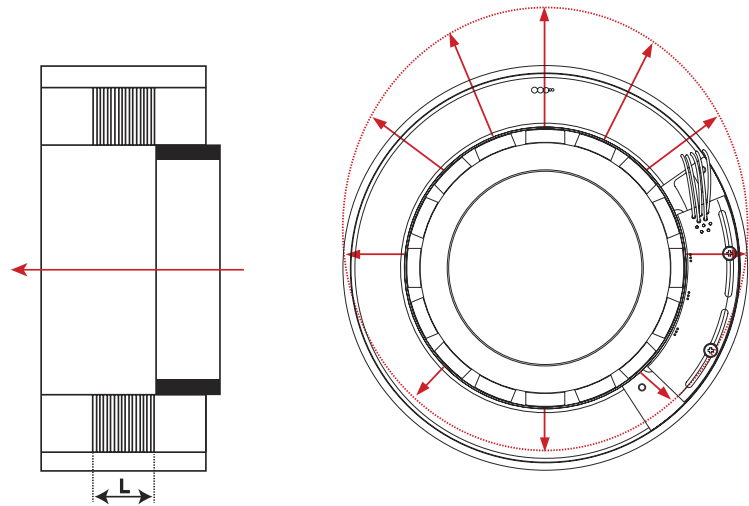

Axial Attraction Force Image

Radial Eccentric Force Image

KBM Mounting Force Summary Table

(See the following page for sample calculations using this table.)

Motor Series	Radial Forces (1)	Radial Forces (2)	Axial Force (3)	Axial Force (4)
KBM(S)-10	45 N/mm	2.57 lb _F /0.010"	96 N	22 lb _F
KBM(S)-14	72 N/mm	4.11 lb _F /0.010"	127 N	29 lb _F
KBM(S)-17	241 N/mm	12.33 lb _F /0.010"	169 N	39 lb _F
KBM(S)-25	365 N/mm	18.72 lb _F /0.010"	248 N	57 lb _F
KBM(S)-35	455 N/mm	23.52 lb _F /0.010"	352 N	80 lb _F
KBM(S)-45	613 N/mm	31.52 lb _F /0.010"	450 N	103 lb _F
KBM(S)-43	780 N/mm	39.97 lb _F /0.010"	370 N	84 lb _F
KBM(S)-57	513 N/mm	26.27 lb _F /0.010"	524 N	120 lb _F
KBM(S)-60	310 N/mm	15.99 lb _F /0.010"	761 N	174 lb _F
KBM(S)-79	508 N/mm	26.04 lb _F /0.010"	741 N	170 lb _F
KBM(S)-88	330 N/mm	16.90 lb _F /0.010"	1214 N	277 lb _F
KBM(S)-118	838 N/mm	42.94 lb _F /0.010"	1539 N	351 lb _F
KBM(S)-163	1198 N/mm	61.44 lb _F /0.010"	1777 N	405 lb _F
KBM(S)-260	800 N/mm	41.11 lb _F /0.010"	2613 N	596 lb _F

(1) given in Newtons [N] per mm of radial eccentricity based on an active stack length of 25 mm

(2) given in Pounds-Force [lb_F] per 0.010" of radial eccentricity based on an active stack length of 1.0"

(3) Maximum attraction force when inserting rotor into stator given in Newtons [N] based on an active stack length of 25 mm

(4) Maximum attraction force when inserting rotor into stator given in Pounds-Force [lb_F] based on an active stack length of 1.0"

Radial Force Sample Calculations

Calculation of the radial force [N/mm] can be performed using:

$$\text{RADIAL FORCE} = \text{TABLE VALUE} \times L/25$$

where L [mm] represents the active length of the lamination stack [approximate using the length of the KBM-XX rotor "B" dimension].

Example: To determine the radial force per mm of eccentricity for a model KBMS-10X03 [use the rotor length of the KBM-10X03 "B" dimension of 57.89 mm] and calculate as follows:

$$\text{FORCE} = 45 \text{ N/mm} \times (57.89/25) = 104.2 \text{ N/mm of eccentricity}$$

Calculation of the radial force [lb_f/0.010"] can be performed using:

$$\text{RADIAL FORCE} = \text{TABLE VALUE} \times L$$

where L [inches] represents the active length of the lamination stack [approximate using the length of the KBM-XX rotor "B" dimension].

Example: To determine the radial force per 0.010" of eccentricity for a model KBMS-10X03 [use the rotor length of the KBM-10X03 "B" dimension of 2.279"] and calculate as follows:

$$\text{FORCE} = 2.57 \text{ lb}_f/0.010" \times 2.279" = 5.85 \text{ lb}_f/0.010" \text{ of eccentricity}$$

Radial Force Sample Calculations

Calculation of the maximum axial attraction force [N] can be performed using:

$$\text{AXIAL FORCE} = \text{TABLE VALUE} \times L/25$$

where L [mm] represents the active length of the lamination stack [approximate using the length of the KBM-XX rotor "B" dimension].

Example: To determine the maximum axial attraction force for a model KBMS-10X03 [use the rotor length of the KBM-10X03 "B" dimension of 57.89 mm] and calculate as follows:

$$\text{FORCE} = 96 \text{ N} \times 57.89 \text{ mm}/25 = 222.3 \text{ N}$$

Calculation of the maximum axial attraction force [lb_f] can be performed using:

$$\text{AXIAL FORCE} = \text{TABLE VALUE} \times L$$

where L [inches] represents the active length of the lamination stack [approximate using the length of the KBM-XX rotor "B" dimension].

Example: To determine the maximum axial attraction force for a model KBMS-10X03 [use the rotor length of the KBM-10X03 "B" dimension of 2.279"] and calculate as follows:

$$\text{FORCE} = 22 \text{ lb}_f \times 2.279" = 50.1 \text{ lb}_f$$

Mounting and Installation Guidelines

Secure the Stator

Confirm that the stator is securely mounted, taking into account the force guidelines above before attempting to install the rotor. Kollmorgen recommends taping or tying the lead and sensor wiring bundle aside in a safe position to avoid accidental damage.

Protect the Running Gap Surfaces

If left unprotected, the outer surface of the rotor may stick or “pole” to the nearest point on the inner bore of the stator due to magnetic attractive forces as the user attempts to install it. The resulting friction as the rotor slides along the inside of the stator can potentially damage the rotor band, magnets, coatings or stator bore surfaces. To prevent damage and simplify the rotor installation process, Kollmorgen recommends first installing a thin layer of shim material, such as Mylar® film, in the stator’s inner bore. See photos below for examples. Mylar (DuPont® Corp. trade name) is a readily available polyester film, often used as electrical insulation or in laminating processes, and is available in a variety of thicknesses. The Mylar film can be installed as a single piece that is wrapped entirely around the circumference of the stator bore and slightly overlapped, or multiple pieces may be inserted axially at equally spaced points. Optimum film thickness and number of shim layers required is dependent upon the gap clearance between rotor and stator for the specific motor size the user is attempting to install. Appropriately thick Mylar film shim layer(s) will keep the rotor roughly centered inside the stator bore and provides a slick surface to slide the rotor to its intended mounting position without damage.



Single Mylar Shim

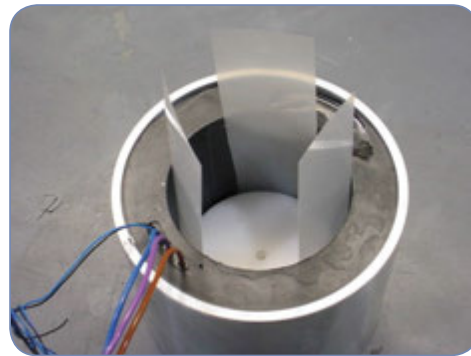

Multiple Mylar Shims

Installing the Rotor

Many of the KBM(S) series rotors are too large to safely lift by hand and the attractive force as the rotor rapidly enters the stator can be too powerful to control by hand. Kollmorgen recommends using a hoist or small overhead crane to lift the rotor into position and stabilize it for safely controlled insertion into the mechanically fixed stator. Most large KBM(S) rotors include tapped holes in the steel hub for the user to attach eye bolts to facilitate hoist lifting. Note that swiveled eye bolts, as opposed to fixed ring eye bolts, are recommended for safe lifting with hoist chain and hook interface.

Inspect the Running Gap

After the rotor is properly installed and secured, remove all Mylar shim material. Carefully inspect the running gap for any debris or obstructions. If possible, spin the rotor by hand to confirm that it rotates freely.

Installation Assistance

Customers may contact Kollmorgen for assistance with application or installation problems. If desired, Kollmorgen can also design and supply custom motor installation fixtures for the user’s unique application needs. Fixture solutions are quoted separately on a case-specific basis.

Performance Enhancements

There are some applications that demand very high torque density that may benefit from specialized cooling of the stator assembly to get significantly increased continuous torque performance. In these applications, Kollmorgen may be able to help with a design for a water jacket or a special air-over cooling package to reduce the winding temperature and increase continuous torque available. Customized cooling solutions are quoted separately on a case-specific basis.

There are also high pressure applications that may benefit from the motor running immersed in a di-electric fluid [hydraulic oil eg: Exxon Univis J-26] to balance the pressure differential in the system. Please consult Kollmorgen to determine the compatibility of the di-electric fluid with our motor material components.

Electrical Wiring Interface

Wiring

KBM(S) series motors are supplied with UL-compliant un-terminated flying leadwires. The user is responsible for proper leadwire routing and connection per the diagrams shown on Kollmorgen drawings. Avoid routing wires across sharp corners, pinch points or edges that may pierce the insulation. Clamp or otherwise secure wire bundle in high vibration applications and avoid wire contact with moving/vibrating surfaces that may abrade the insulation. Provide strain relief for all wire bundles and allow room for a generous bend radius. User assumes responsibility for connector installation, crimping, soldering, shielding, sleeving or any other wire bundling or electrical interface enhancement beyond the configuration shown on the Kollmorgen outline drawing.

Thermistors

To provide for continuous safe operation of KBM(S) series motors in demanding applications, integral thermistors are mounted in the stator. These passive devices provide an output characteristic [Avalanche type] as shown in the side table for use in typical control safety circuits as the temperature goes beyond the rating of the motor windings [155C]. The KBM[S]-10XXX through KBM[S]-35XXX and KBM[S]-45XXX motors all have a single avalanche type thermistor while the balance of the KBM[S] family motors have two or three wired in series or independently depending on the model number. Linear thermistors are optionally available for use in winding temperature data acquisition and exhibit a basically linear resistance characteristic over the operating range of the motor.

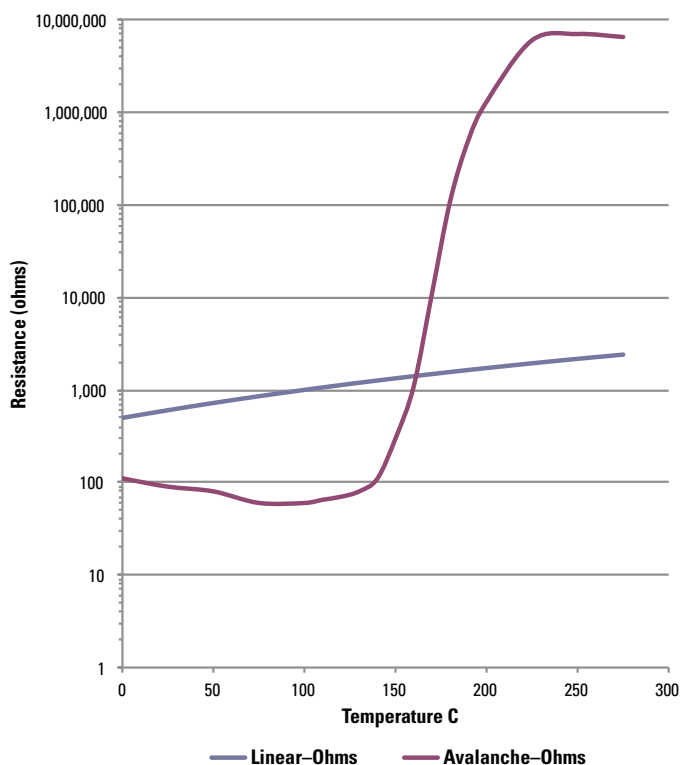

Mounting and Installation Guidelines

Wiring Diagram

If the distance between motor and servo drive exceeds 500 mm, it is highly recommended to use shielded cables to ensure proper function and EMC behavior of the system. Refer to the diagram below for a KBM[S] interface to a typical drive system.

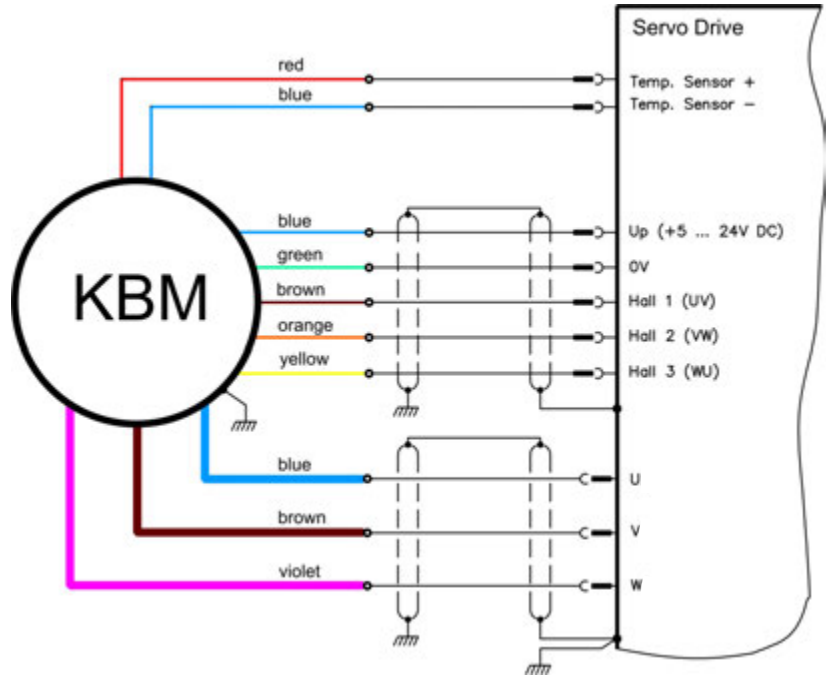

Typical KBM(S)/Drive System Interface

Thermistor lead colors and number of leads vary depending on model number. Consult specific model frame size page for further detail.

Sensor Wiring Diagram

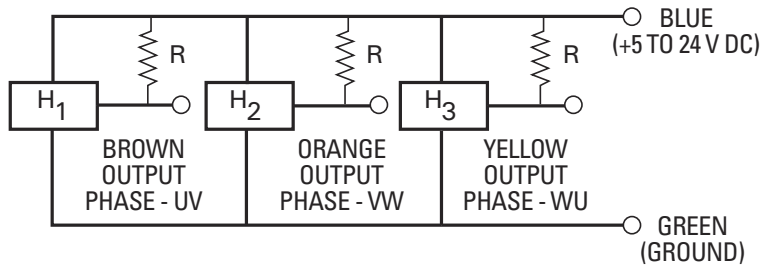

Excitation Sequence Table

STEP	Power Connection		
	Phase 'U' Blue	Phase 'V' Brown	Phase 'W' Violet
1	⊕	⊖	
2	⊕		⊖
3		⊕	⊖
4	⊖	⊕	
5	⊖		⊕
6		⊖	⊕

CCW viewed from lead end

Sensor Output

CCW viewed from lead end

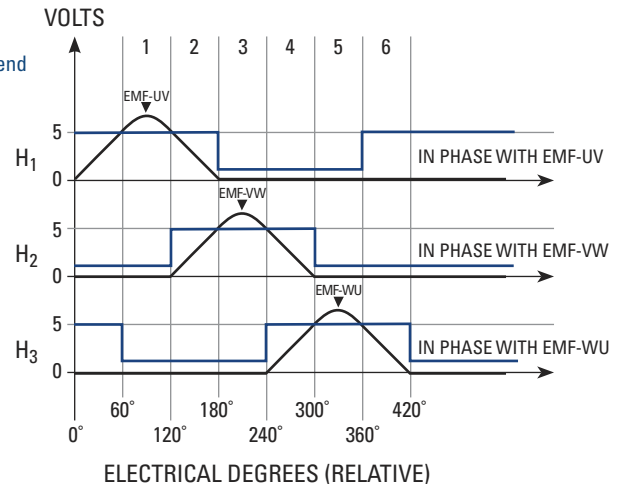

Application Profile Questions

MOTOR REQUIREMENTS

Motor Type

- Housed
- Frameless
- Feedback options
 - Tachometer
 - Encoder
 - Resolver
 - Hall sensors
 - Other

Operating Environment

Operating temp: Min _____ Max _____
Ambient temp: Min _____ Max _____
Other: _____

Performance Data

Max speed: _____
Max torque: _____
Operating speed: _____
Operating torque: _____
Duty cycle: _____

Mechanical Envelope

Mounting requirements: _____
Dimensional requirements: _____
Inside dimensions: Min _____ Max _____
Outside dimensions: Min _____ Max _____
Weight requirements: _____
Available cooling: _____
Other requirements: _____

CONTROL / DRIVE REQUIREMENTS

Supply Voltage, AC/DC: _____

Peak and Continuous Current: _____

Commutation Type

- Sinusoidal
- Six-step

Control Loop Type

- Torque
- Velocity
- Position

Operating Environment

Operating temp: Min _____ Max _____
Ambient temp: Min _____ Max _____
Other: _____
Other requirements: _____

To discuss your application in more detail or for assistance in selecting the proper KBM(S) series motor, please contact Kollmorgen Customer Support at 540-633-3545 or through email at support@kollmorgen.com.

KBM Frameless Motor Nomenclature

KBM Frameless Motor

KBM(S) - 25 H 01 - A XX

Product Family

KBM = Frameless motor

KBMS = Frameless motor with sensors

Motor Frame Size (Armature I.D.)

10	57
14	60
17	79
25	88
35	118
43	163
45	260

Insulation Ratings

H = High voltage insulation (>240 Vac), S = Low-Voltage insulation (\leq 240 Vac)

Note: H insulation is standard option for frame sizes 10, 14, 17, 25, 35 and 45.

Sequential Number for Available Modifications

Winding Options

(A, B, C, etc...)

Stack Length Specifier

00 = 0

01 = 1

02 = 2

03 = 3

04 = 4

05 = 5

Available KBM(S) Modifications

The following modifications allow our customers to optimize the base model configuration to meet the unique challenges of their application needs. Please consult Kollmorgen Customer Support for information, pricing, and feasibility of desired modifications. Engineering and soft tooling fees may be required. Additional lead time required.

Speed/Torque Changes

- Winding Gages
- Stack Lengths Available

- Pole Count
- Magnet Materials

Generally Available Capability

#00 – #48 AWG (*includes lead wire change*)
6.35 mm (0.25 in) to 610 mm (24 in)
(Rotor length, including magnets, will increase or decrease proportionally)
6 to 64 Poles
Neodymium-Iron-Boron
Samarium Cobalt

Durability/Harsh Environment

- Rotor Hub Material
Bare Cold-Rolled Steel (*base model*)
Corrosion-resistant Stainless Alloy
- Stator Sleeve Material
Bare Aluminum (*select base models*)
Stainless or Carbon Steel
- Armature Potting
Encapsulation (*base model*)
Varnish
Hi-Temp Encapsulation (200°C)
- Corrosion Protection
Dri-Touch Corrosion Inhibitor (*base model*)
Nickel Plating, Passivation, Anodizing
Epoxy Paint

Installation Features

- Rotor Hub Geometry
Round, hollow, flanged, keyway, flat
Thru bores from 5 mm to 600 mm
- Mounting
Bolt hole diameter and circumferential pattern (*customer specified*)
- Lead Length
400 mm (15.75 in) min (*base model*)
150 mm to 1200+ mm (*customer specified*)
- Lead Colors
Blue / Brown / Violet (*base model*)
Other colors to be specified by customer
- Thermal Sensor
Thermistor-Avalanche (*base model*)
Thermistor-Linear
- Connector(s)
Flying leads (*base model*)
Connector(s) specified by customer

About Kollmorgen

Kollmorgen is a leading provider of motion systems and components for machine builders. Through world-class knowledge in motion, industry-leading quality and deep expertise in linking and integrating standard and custom products, Kollmorgen delivers breakthrough solutions that are unmatched in performance, reliability and ease-of-use, giving machine builders an irrefutable marketplace advantage.

For assistance with your application needs in North America, contact us at: 540-633-3545, support@kollmorgen.com or visit www.kollmorgen.com for a global contact list.

- Application Centers
- Global Design & Manufacturing
- Global Manufacturing

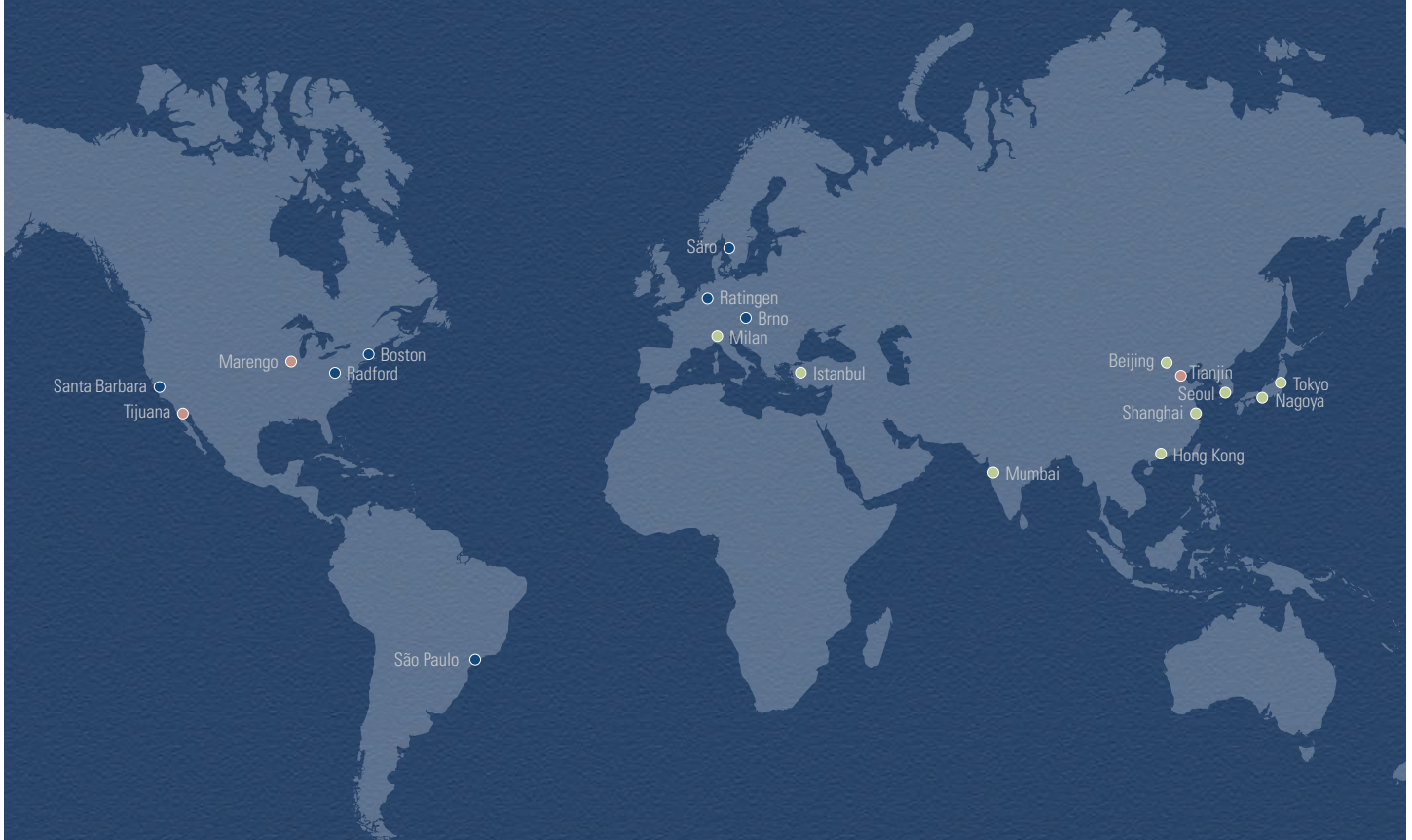

KOLLMORGEN®

Because Motion Matters™

Kollmorgen
203A West Rock Road
Radford, VA 24141 USA
Phone: 1-540-633-3545
Fax: 1-540-639-4162

Kollmorgen Europe GmbH
Pempelfurtstraße 1
40880 Ratingen
Germany
Phone: +49 (0) 2102 9394 0
Fax: +49 (0) 2102 9394 3155

Kollmorgen Asia
Rm 202, Building 3, Lane 168
Lin Hong Road
Changning District, Shanghai 200335, China
Phone: +86 400 661 2802
Fax: +86 21 6071 0665

Kollmorgen Aerospace and Defense
501 West Main Street
Radford, VA 24141 USA
Phone: 1-540-731-5668
Fax: 1-540-731-5679